

# INSTALLATION INSTRUCTIONS

# **EGR** ***ROLLTRAC***

## ELECTRIC

**Vehicle Model: Ford F-250 6.5Ft Bed RHD&LHD - Compatible with Boxlink®**  
**Year of manufacture: 2018 onwards**  
**Part Number: RT040031E**

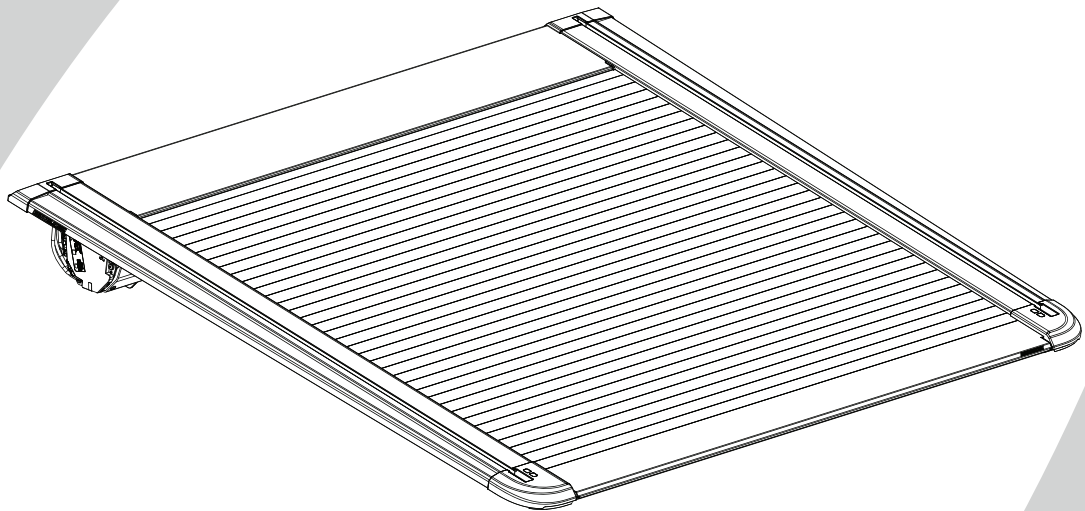

Installation time: 180 minutes

### Caution

- Do not attach EGR RollTrac in a location or by a method not specified.
- Do not use this product for any vehicle make or model, other than those specified in this document.
- Do not remove the plaque or label from this product.
- Do not modify the structure of the EGR RollTrac in any way.

### General Notes

- Read through the fitting instructions before installation of EGR RollTrac.
- Always install the accessory following the fitting instructions. Failure to do so may cause damage to the vehicle or the accessory.
- Ensure all recyclable discarded vehicle accessory components and packaging are recycled following local recycling regulations.
- It is always recommended that this accessory is fitted by a qualified Technician.
- Safely store and protect any removed vehicle components.
- Ensure all bare metal surfaces are protected using Automotive Bare Metal Primer and touch-up paint.
- Remove all metal swarf and dust from all vehicle surfaces if surface is used for accessory installation.



### Safety Notes

- Check that all work practices comply with safety standards.
- Please wear appropriate clothing and use safety equipment.



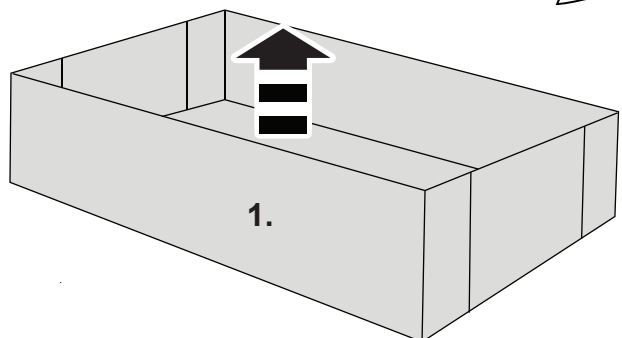
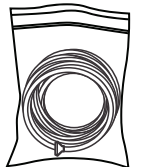
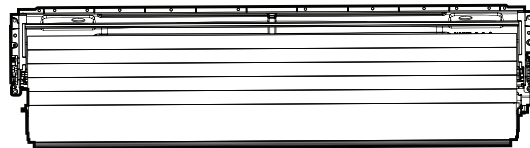
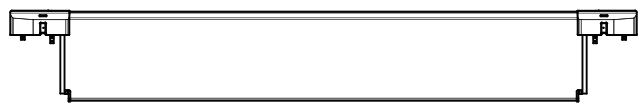
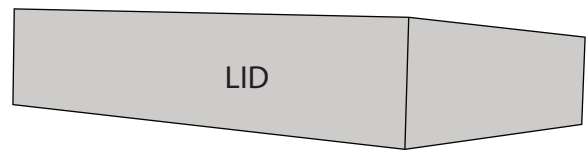
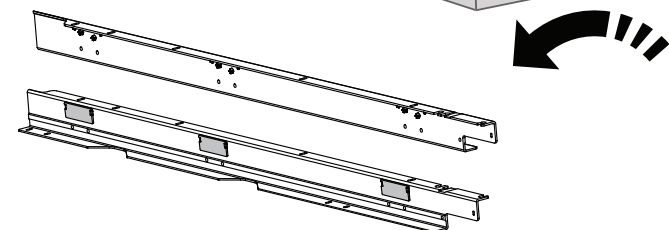
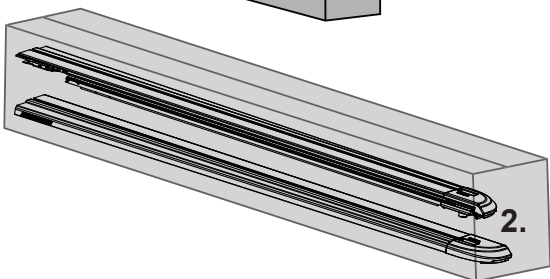
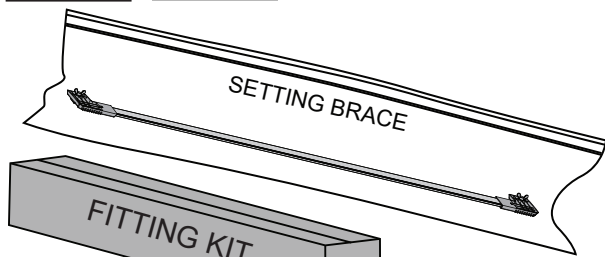
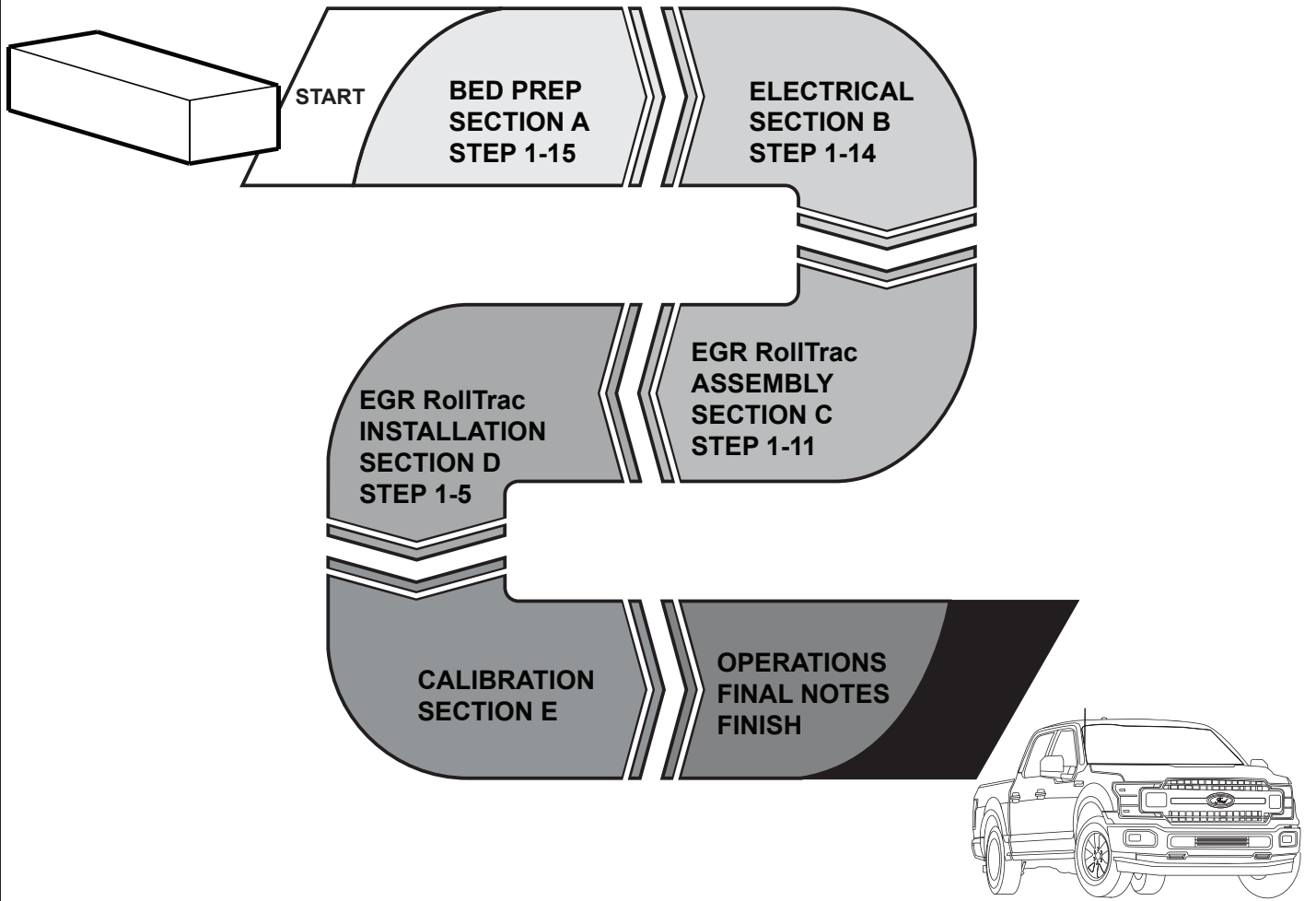

## KIT CONTENTS - COMPONENT NUMBER AND QUANTITY

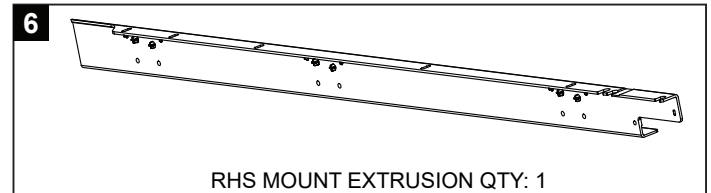
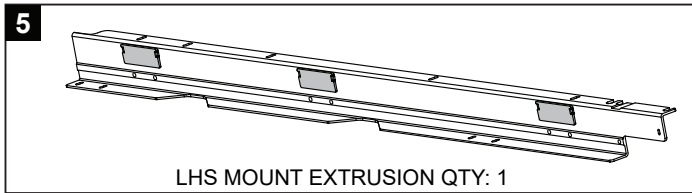
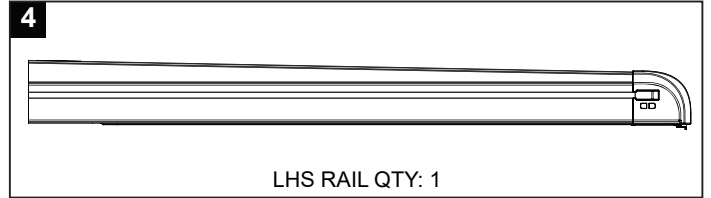
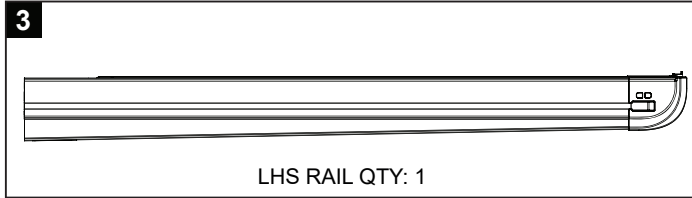
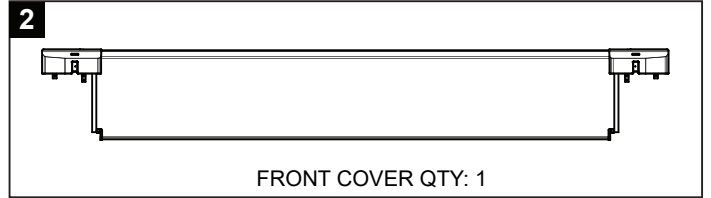
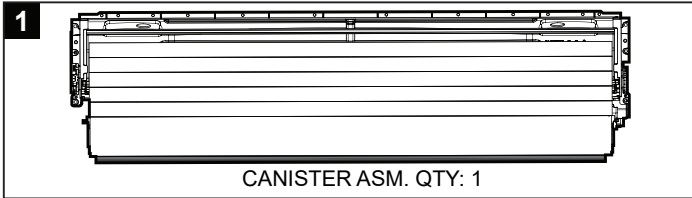

### EGR RollTrac M-Bar Assy Hardware Kit

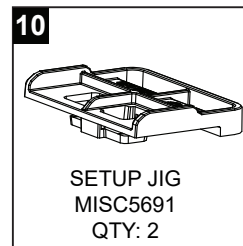
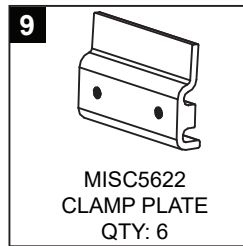
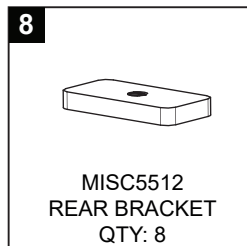
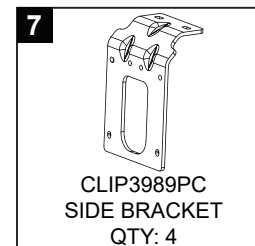

### EGR RollTrac FITTING KIT IN BOX

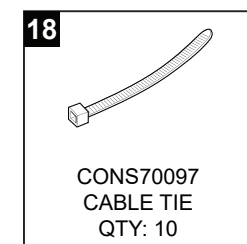
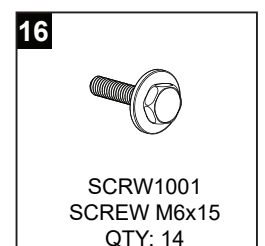
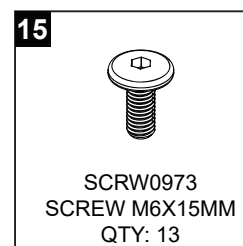
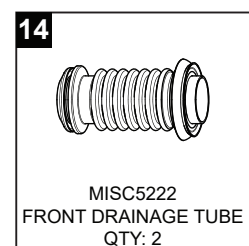
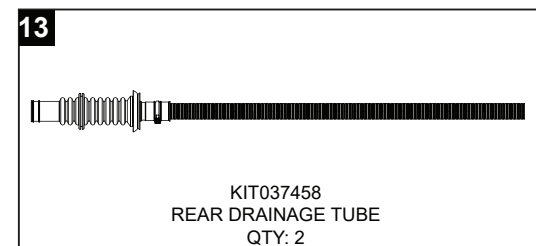

### SETTING BRACE



# EGR RollTrac FITTING KIT COMPONENTS IN BAGS

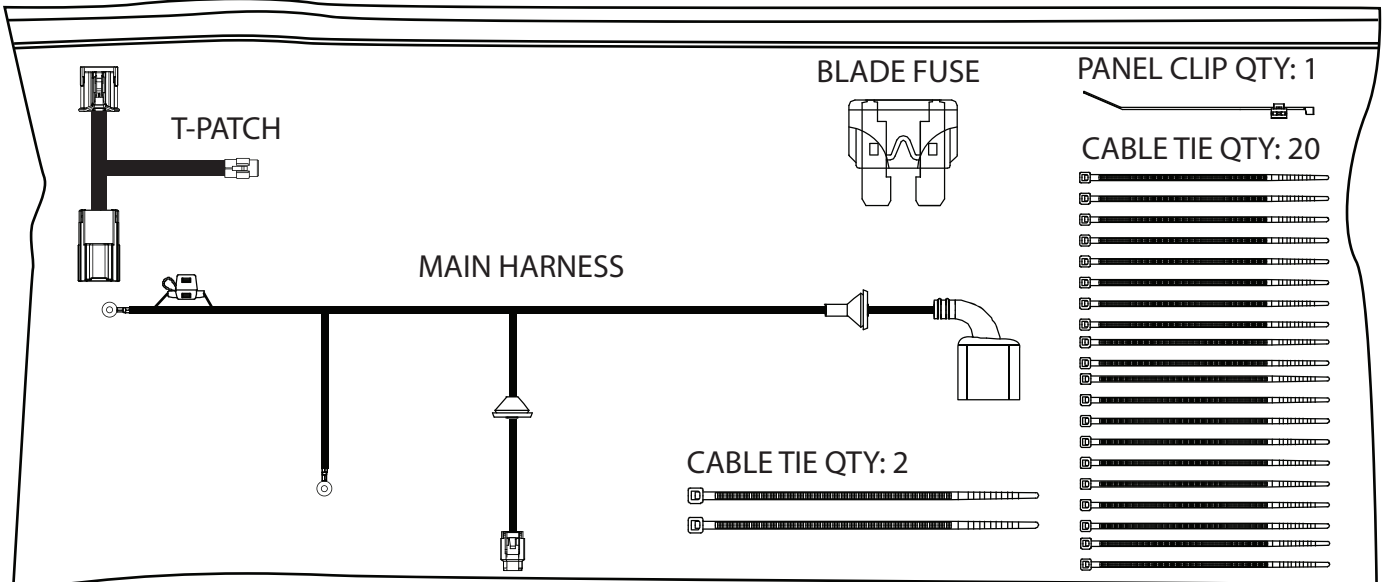

# EGR RollTrac FITTING KIT ADDITIONAL ITEMS

**19**

RUBBER EXTRUSION  
QTY: 1

**20**

RUBBER EXTRUSION  
QTY: 2

INSTALLATION INSTRUCTIONS

OWNERS MANUAL



# TOOLS REQUIRED - NOT SUPPLIED IN KIT

<p>Drill</p>	<p>Holesaw Ø29mm (1 1/8") Ø38mm (1 1/2")</p>	<p>Centre Punch &amp; Hammer</p>	<p>Drill Stop</p>	<p>Drill Bits Ø5mm (3/16")</p>	<p>Scissors</p>	<p>Masking Tape Fiberglass Tape Black Cloth Tape</p>
<p>Ratchet &amp; Sockets 7mm (9/32") 10mm (25/64") 13mm (33/64")</p>	<p>Allen Key 4mm (5/32")</p>	<p>Allen Key 2.5mm (3/32") 4mm (5/32")</p>	<p>Torque Wrench</p>	<p>Side Cutters</p>	<p>Soapy Water</p>	
<p>50/50 Isopropyl Alcohol/Water</p>	<p>ANTI RUST Rust Inhibitor</p>	<p>Silicone</p>	<p>Anti-abresion tape to seal holes &amp; slots</p>	<p>Silicone Spray</p>		
<p>METRIC Tape Measure</p>	<p>Ruler x2</p>	<p>3M Primer 94 (preferred) or equivalent</p>	<p><b>GLOSSARY:</b></p> <p><b>1</b> Number inside a square indicate part number</p> <p><b>1</b> Number inside circle indicate the sequence within a step</p> <p><b>1</b> Number inside the hexagon indicate torque instruction</p>			

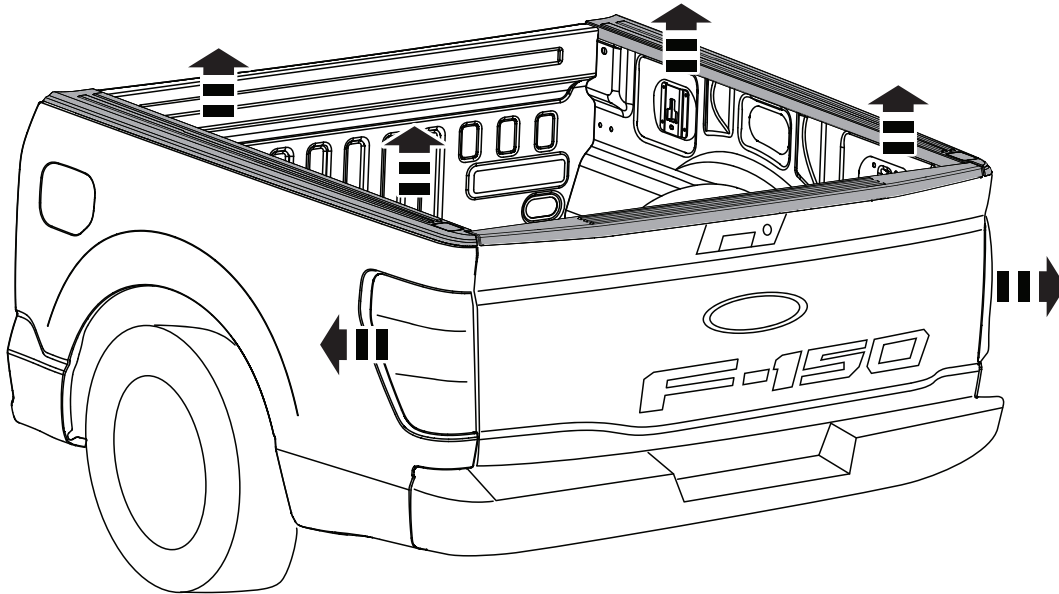
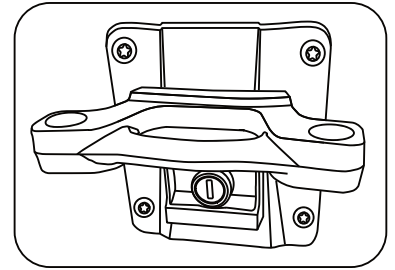
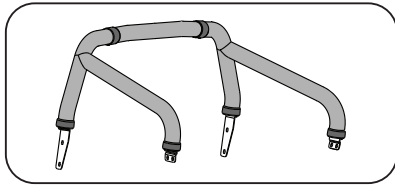

- 1 Carefully remove any accessories (Sports Bars, Cabin Guards, etc.) attached to the bed of the vehicle. Thoroughly wash the vehicle and bed and ensure that all dirt and grease is removed. Allow to dry. Clean the top surfaces of the bed and tailgate and allow to dry. Carefully remove both Rear Tail Lamps with the appropriate tools and store in safe place. Retain all hardware for re-installation. **IMPORTANT:** Remove and retain Tie Down Hooks with mounting plates. Discard the screws.

CONTINUE ON THE NEXT PAGE

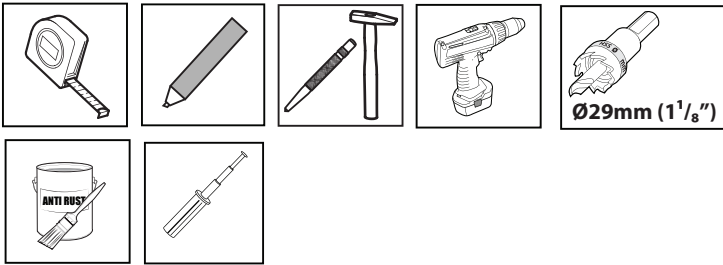

**HOLE FOR MAIN HARNESS  
LHS ONLY !**

**ATTENTION**  Ensure that the diameter of the hole does not exceed  $\varnothing 29\text{mm}$  ( $1\frac{1}{8}''$ ). Larger hole size will lead to water ingress into the bed

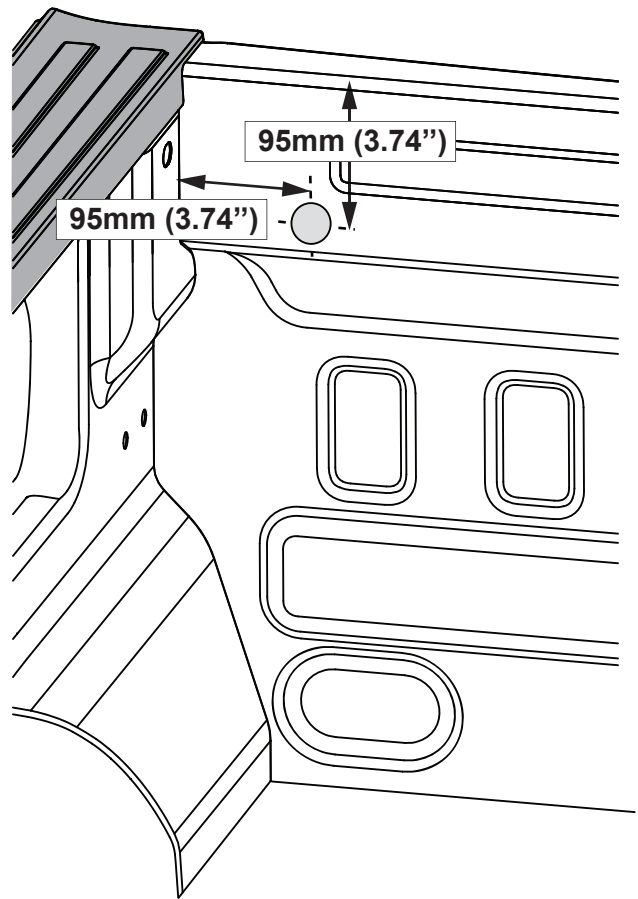

**2** On the front LHS of the bed, mark the position for the Main Harness grommet and drill with  $\varnothing 29\text{mm}$  ( $1\frac{1}{8}''$ ) holesaw. Clean all burrs and coat the exposed metal with a suitable rust preventative (not supplied).

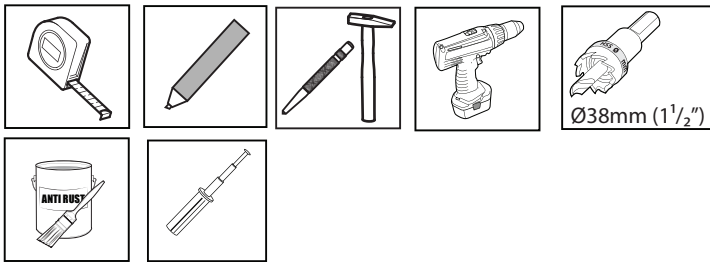

**HOLES FOR FRONT DRAIN TUBES  
RHS & LHS**

**ATTENTION**  Ensure that the diameter of the hole does not exceed  $\varnothing 38\text{mm}$  ( $1\frac{1}{2}''$ ). Larger hole size will lead to water ingress into the bed

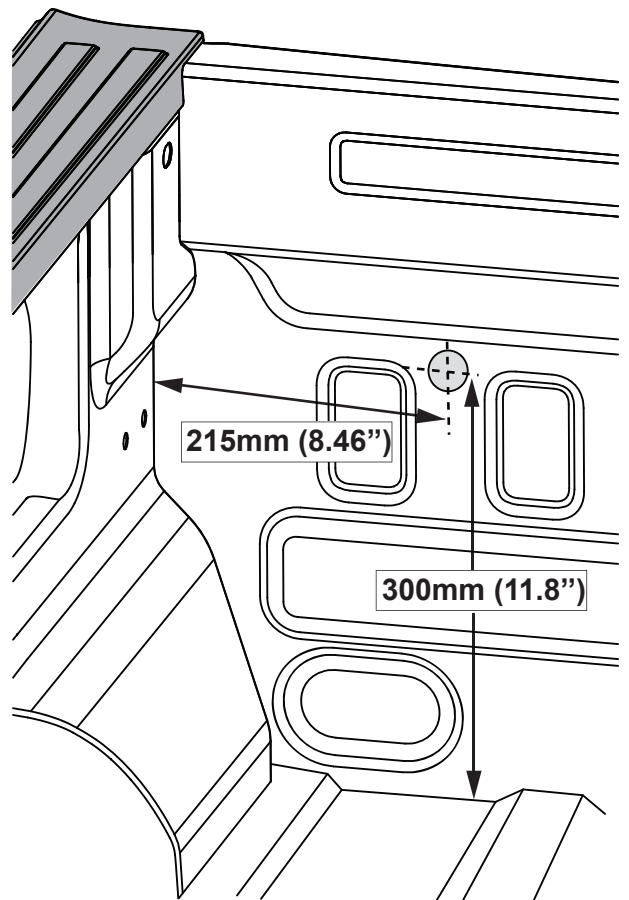

**INSTALL FRONT DRAIN TUBES TO BED**

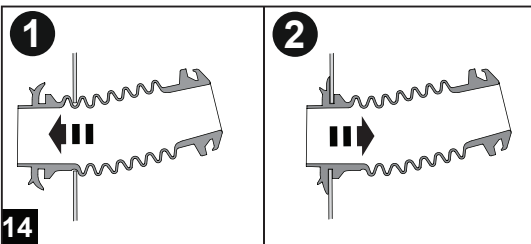

**3** Mark the position of the front drain tubes holes in the bed front panel and drill with  $\varnothing 38\text{mm}$  ( $1\frac{1}{2}''$ ) holesaw. LHS shown, repeat on the RHS. Clean all burrs and coat the exposed metal with a suitable rust preventative (not supplied). Fit front drain tubes (14).

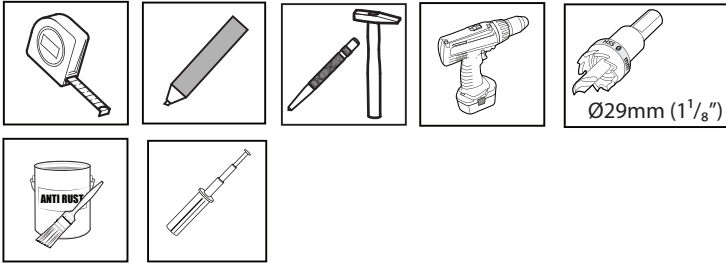

## HOLES FOR REAR DRAIN TUBES RHS & LHS



**ATTENTION** Ensure that the diameter of the hole does not exceed  $\text{Ø}29\text{mm}$  ( $1\frac{1}{8}$ " ). Larger hole size will lead to water ingress into the bed

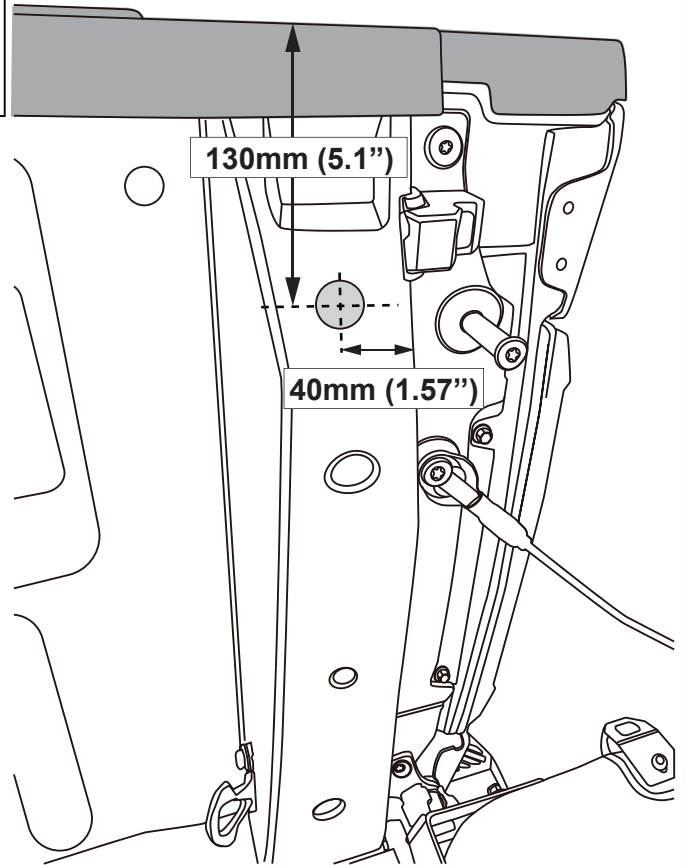

- 4** Mark the position of the rear drain tubes holes in the bed rear panel and drill with  $\text{Ø}29\text{mm}$  ( $1\frac{1}{8}$ " ) holesaw. LHS shown, repeat on the RHS. Clean all burrs and coat the exposed metal with a suitable rust preventative (not supplied).

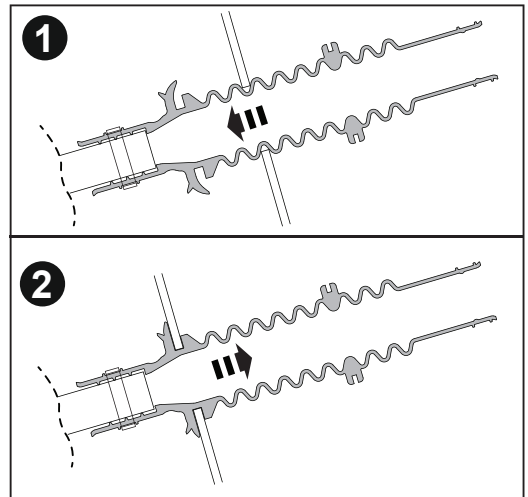
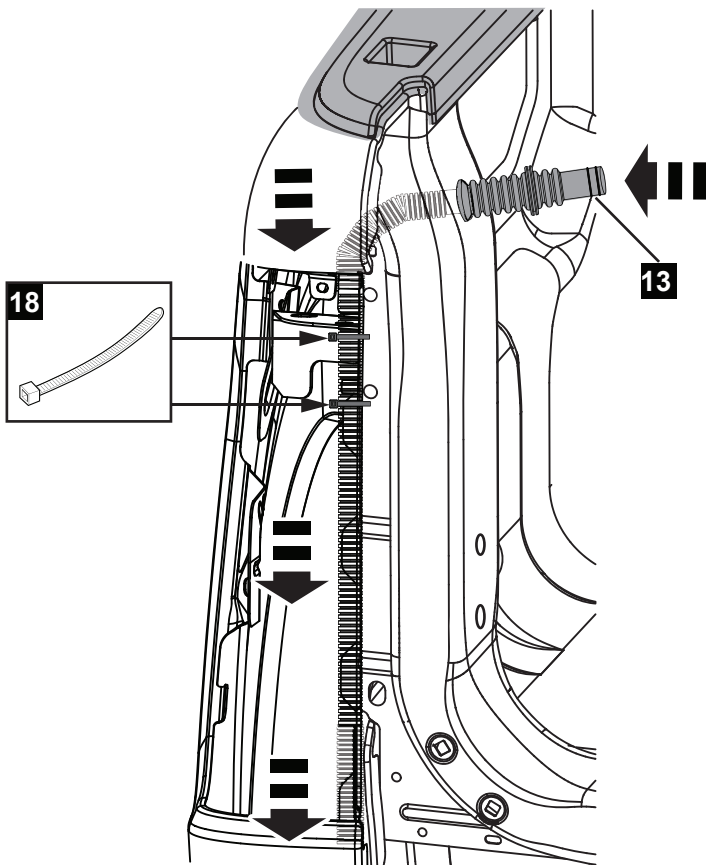

- 5** Feed the rear drain tube into the drilled hole. Guide the plastic tube inside the tail light cavity towards the ground. Push the rubber tube in until it sits firmly in the hole as shown. Secure the drain tube (13) to the existing harness inside the tail light cavity using 2 cable ties (18). Refit Rear Tail Lamps.

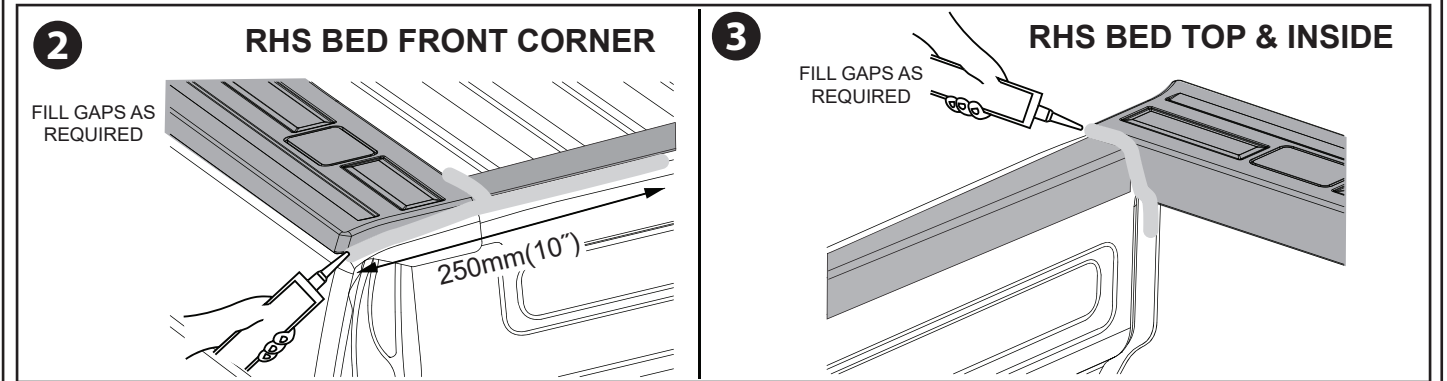
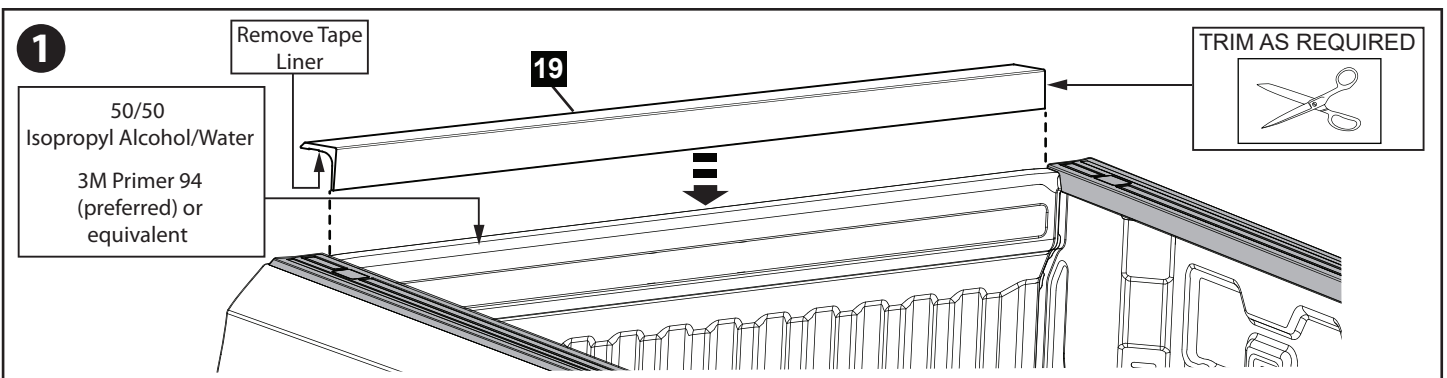

**6** Clean the front top of the bed using Isopropyl Alcohol/Water mix and apply primer to the top area. Allow to dry. Place the extrusion (19) on front of the vehicle bed, check the length and trim to full width if required. Pre-peel 50mm (2") of the tape liner from one end of the Rubber Extrusion (19). Place the Rubber Extrusion on top of the bed as shown and centralise. Once in position, peel the liner and apply firm pressure from the top. Silicone the gap between the panels as shown on both sides. NOTE: Holes in the bed should be sealed with Silicone to prevent dust and water ingress as required.

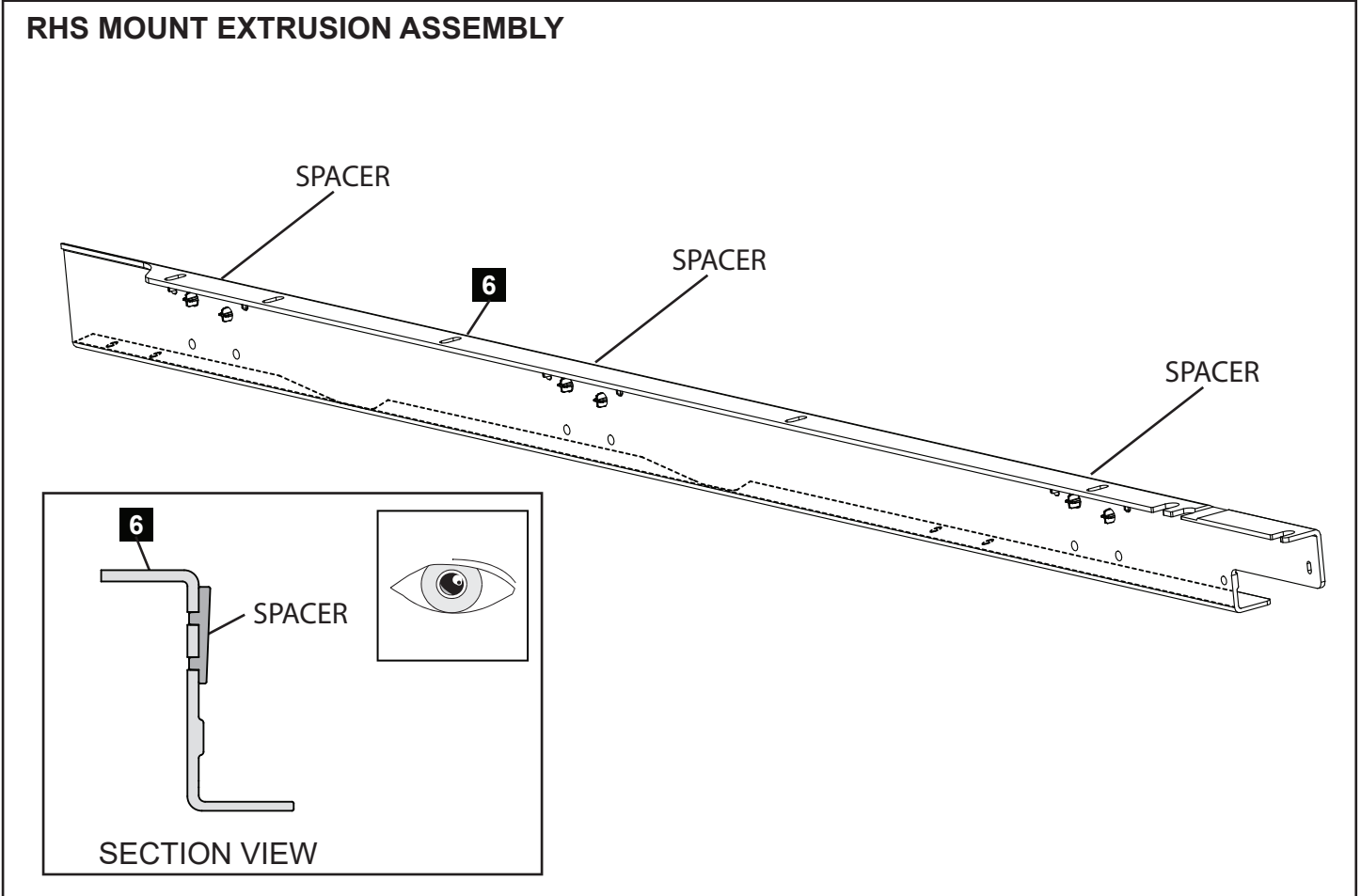

**7** Check if the plastic spacers are in place, if they have fallen out during transport, please refit.

## LHS MOUNT EXTRUSION ASSEMBLY

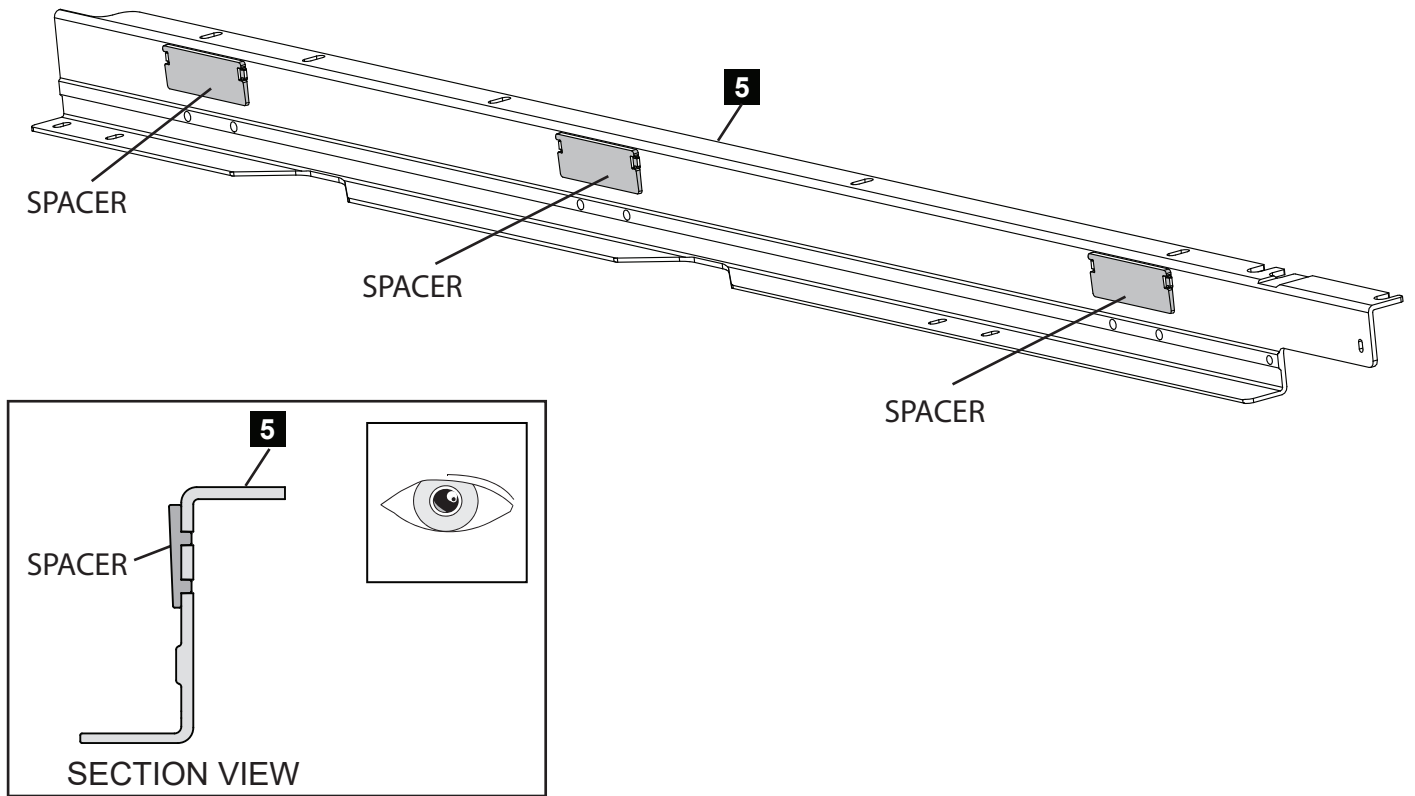

**8** Check if the plastic spacers are in place, if they have fallen out during transport, please refit.

## RHS MOUNT EXTRUSION ASSEMBLY

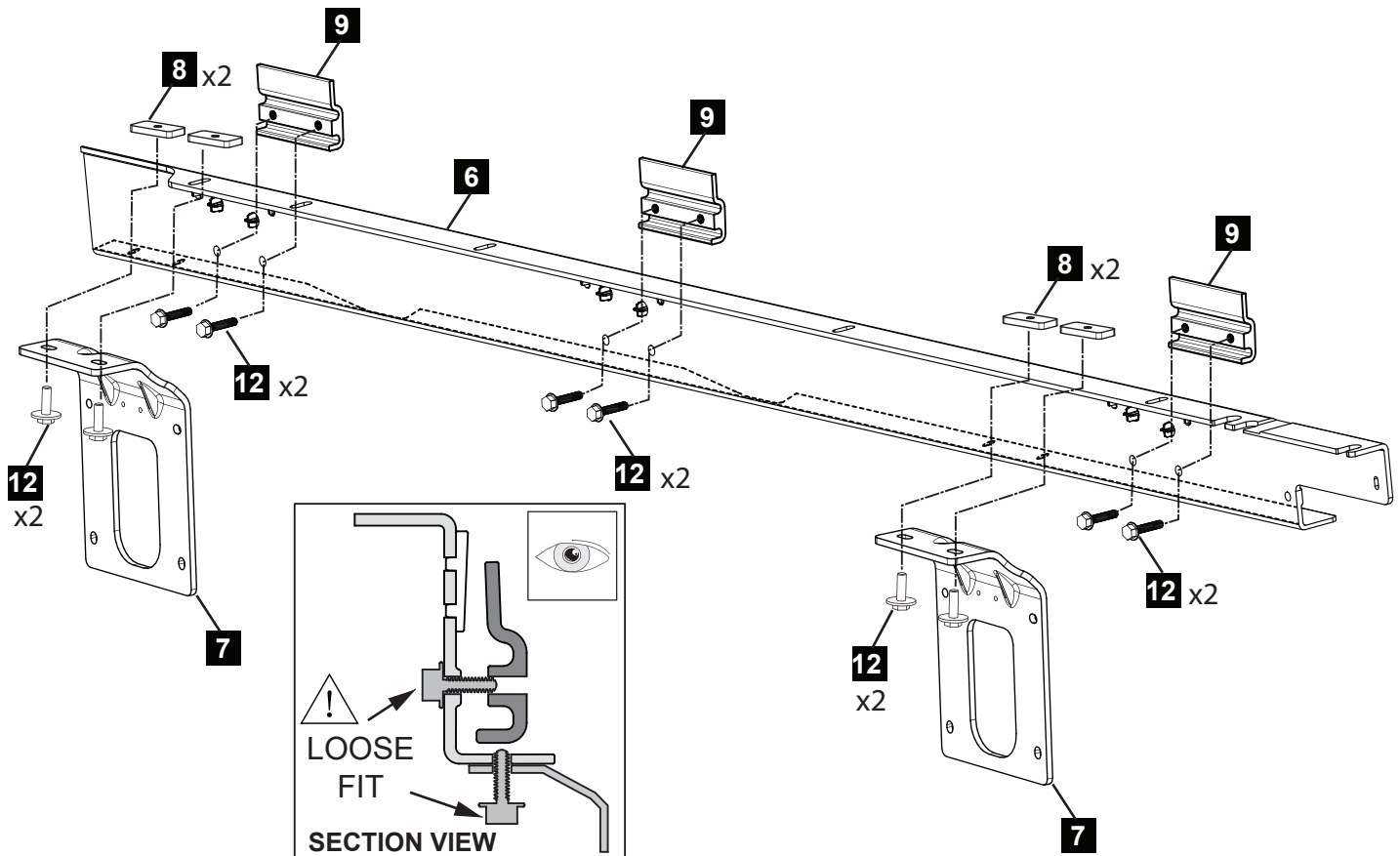

**9** Fit the side brackets (7) to the mount extrusion (6) as shown. Do not torque the screws at this stage.  
**Attention:** Fit screws only two rotations into the plates.

## LHS MOUNT EXTRUSION ASSEMBLY

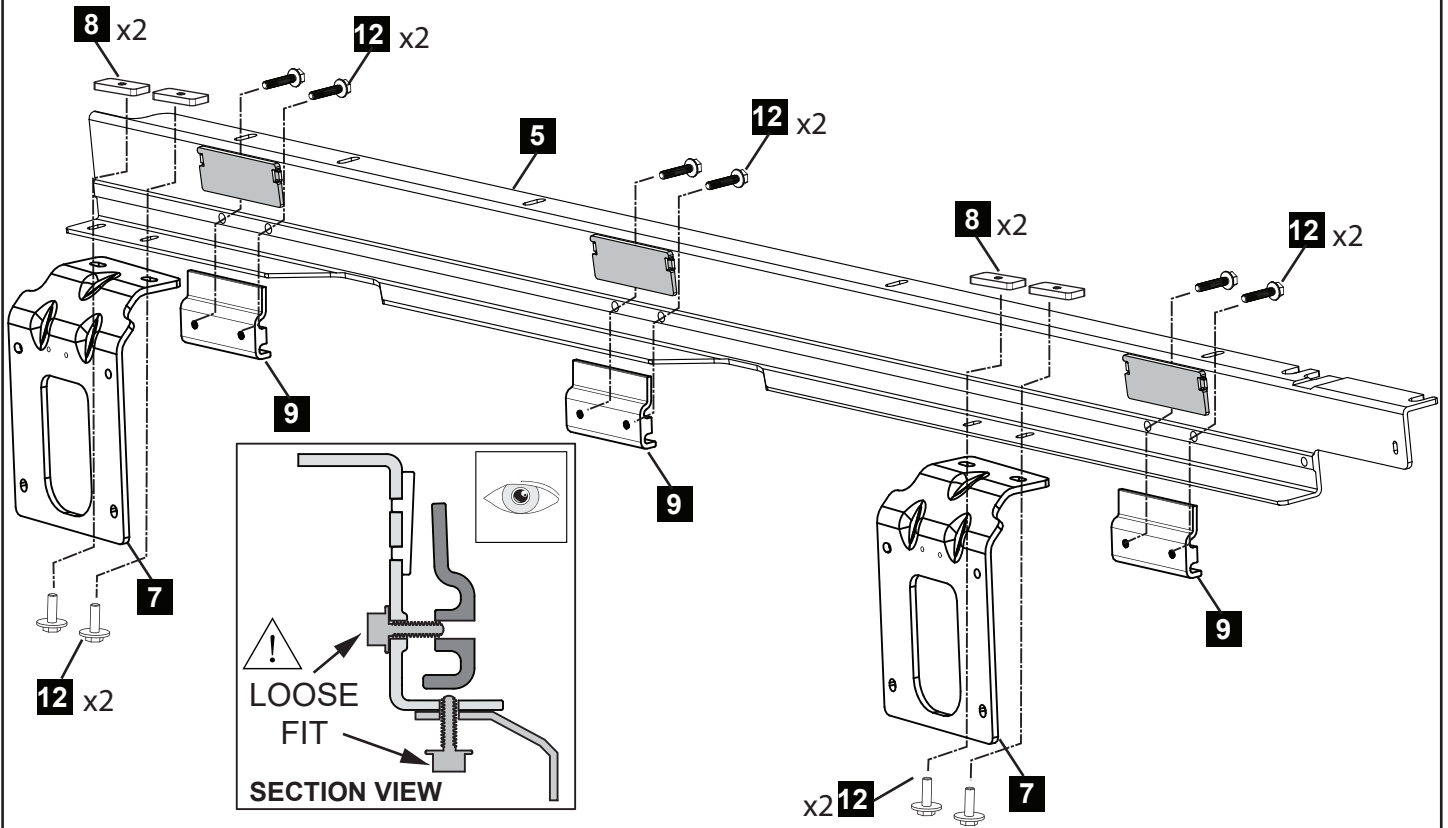

- 10** Fit the side brackets (7) to the mount extrusion (5) as shown. Do not torque the screws at this stage.  
**Attention:** Fit screws only two rotations into the plates.

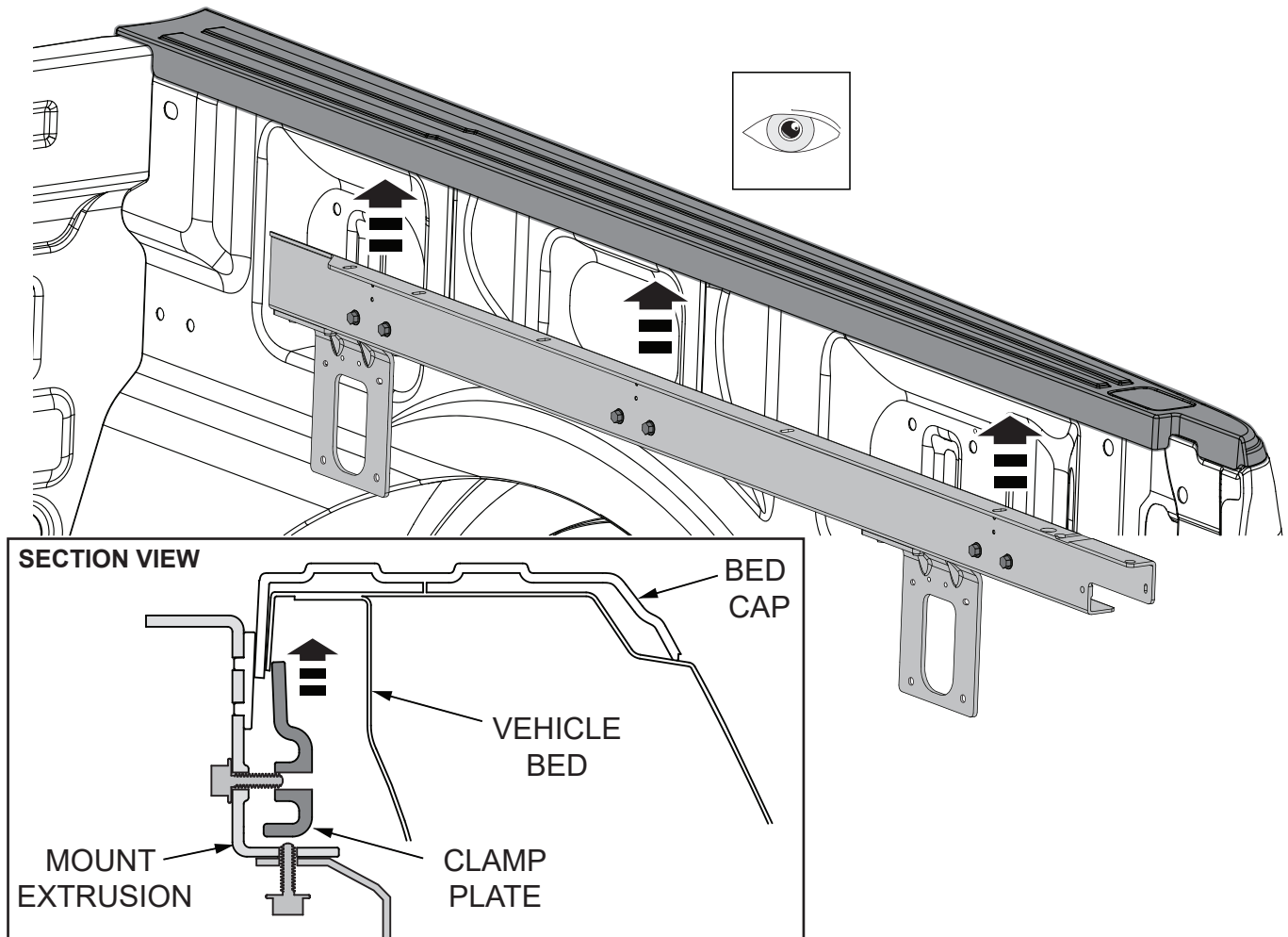

- 11** Fit the mounting bar assembly onto the vehicle bed, by moving it up vertically until the clamps grab the lip of the bed as shown in the section view.

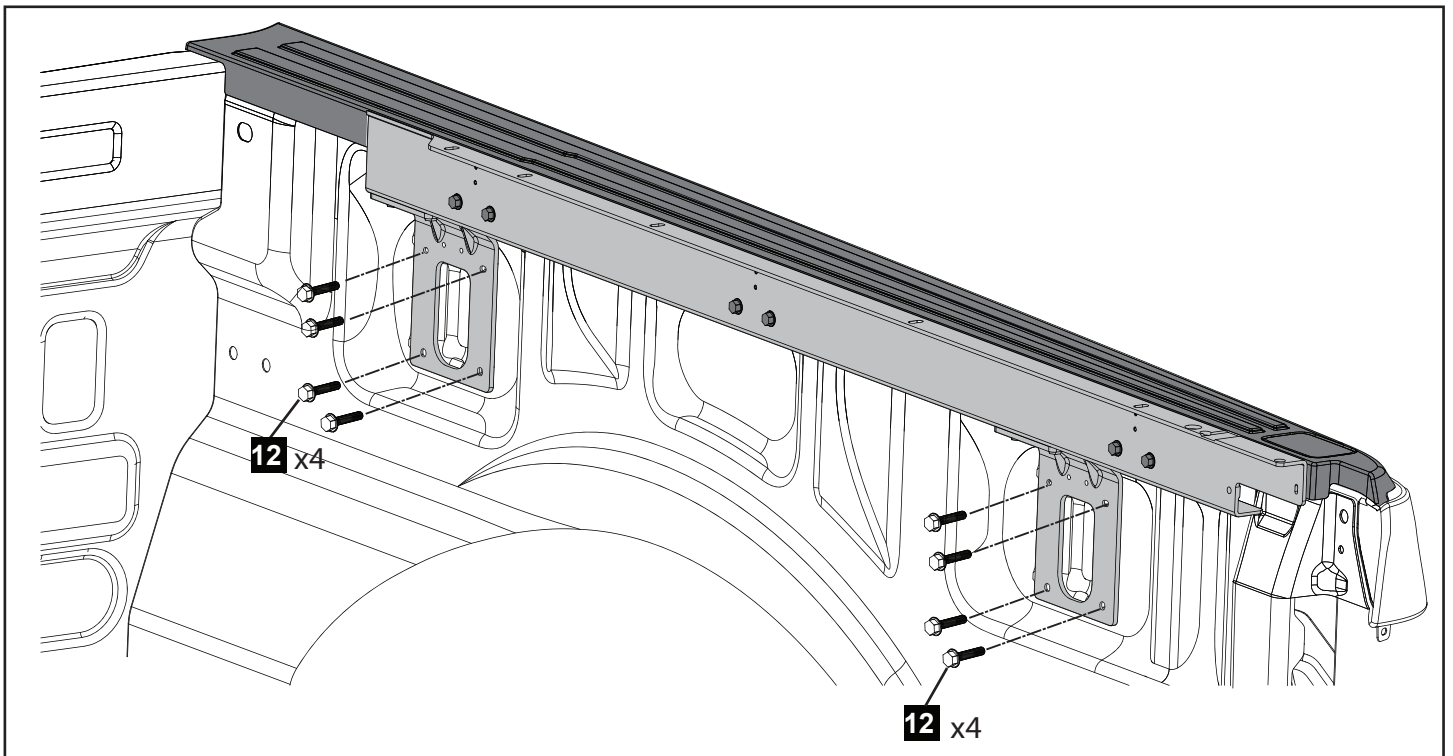

**12** Note: Trucks without factory supplied cargo hooks may need to be threaded/tapped M6xPitch:1.0  
Hold the assembly in position and fit screws (12). Do not torque the screws.

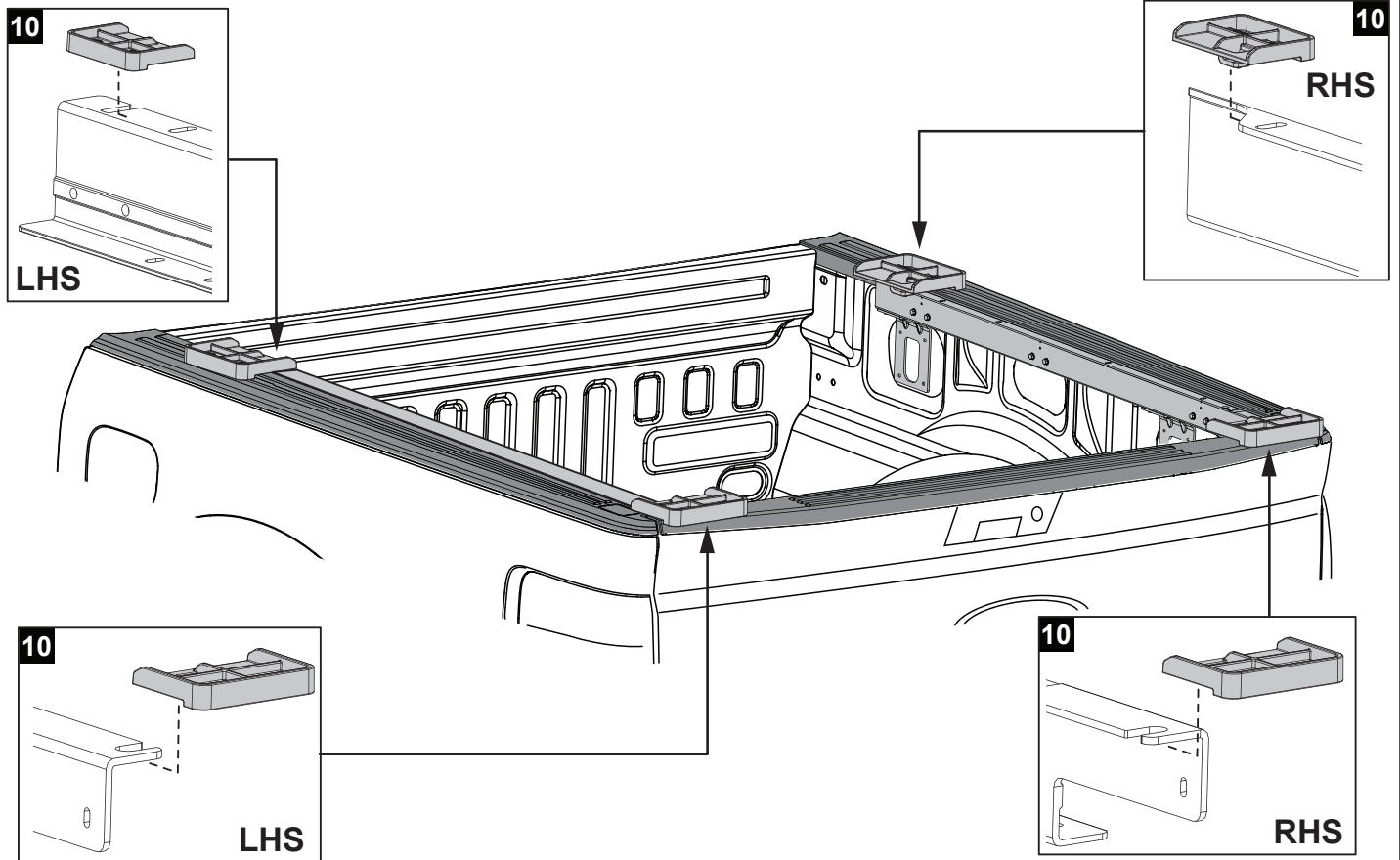

**13** Fit the setup jigs, to set up the RH mount extrusion first. Adjust the mount extrusion front position to the bed cap and rear position to the top of the tailgate using the setup jigs as a guide.

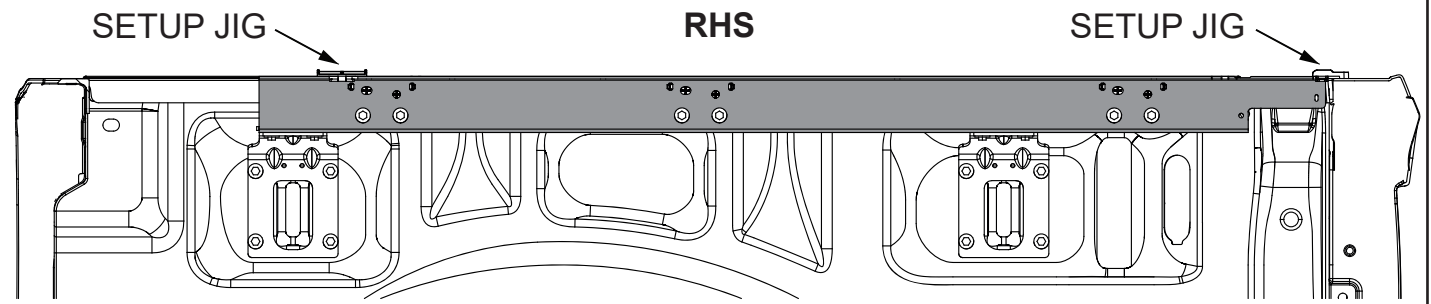
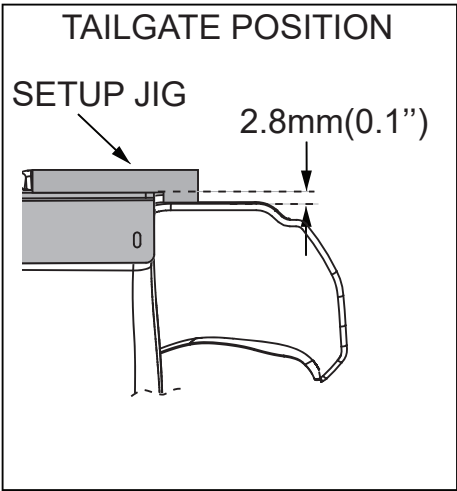
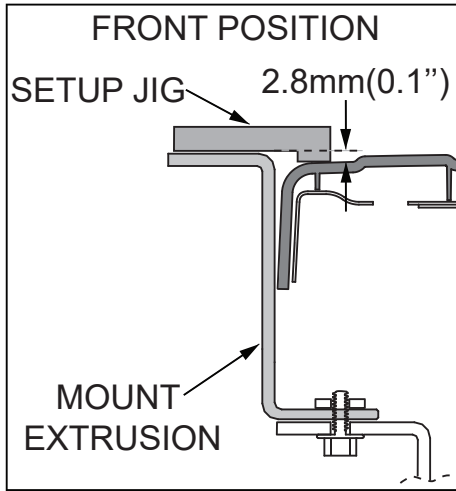
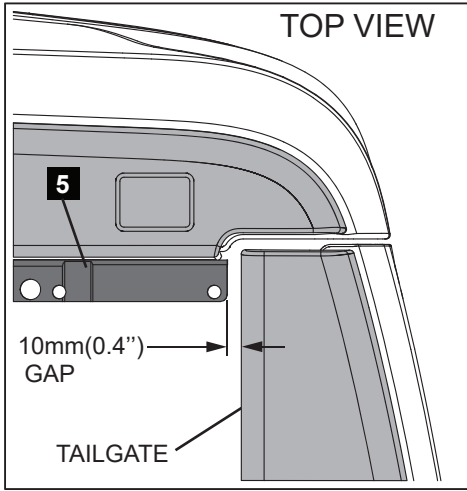

- 14** Set front/back position of the mount extrusion relative to the tailgate 10mm(0.4") gap as shown in top view. Set the vertical position of mounting extrusion by adjusting the extrusion relative to the bedcap (ensuring parts are held level). Use the setup jigs to achieve a 2.8mm(0.1") step between the front end of the extrusion Vs bedcap; and a 2.8mm(0.1") step between the rear end of extrusion Vs tailgate - as shown in detail views above.

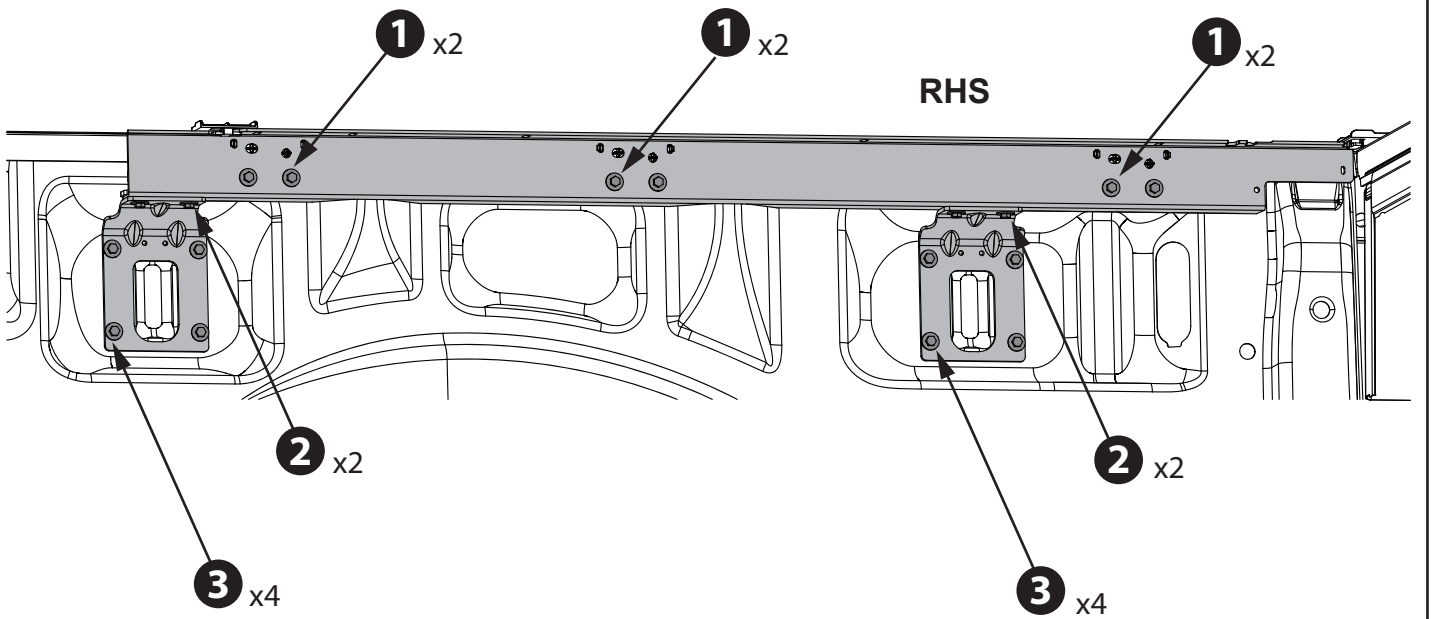
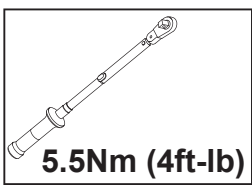
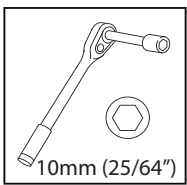

- 15** Torque all screws to 5.5Nm(4ft-lb) in order shown above. Recheck mounting extrusion position from step 13 and remove setup jigs. Repeat step 10-14 on LH side.

**SECTION B**

**ELECTRICAL LOOM INSTALLATION**



WHILE ROUTING THE VEHICLE HARNESS AVOID ANY VEHICLE COMPONENTS THAT HEAT UP, SUCH AS EXHAUST AND ENGINE COMPONENTS. DO NOT ATTACH HARNESS TO MOVING PARTS, FUEL LINES, BRAKE LINES, MOVING PARTS AND AVOID PINCH POINTS. ENSURE VEHICLE PARTS ARE AT AMBIENT TEMPERATURE BEFORE PERFORMING FITMENT.



**HARNESS ROUTING OVERVIEW**

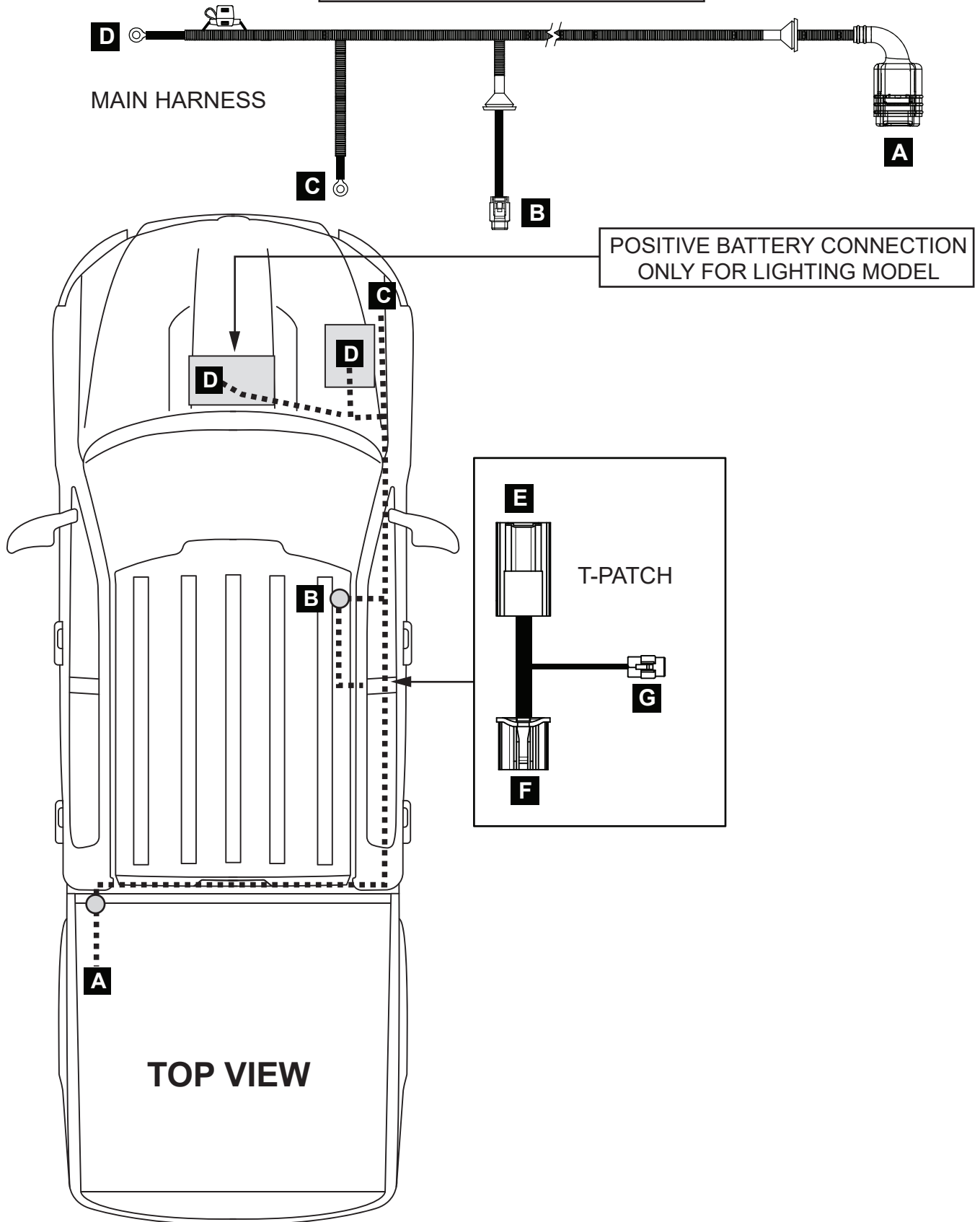

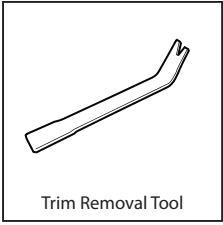

RHS

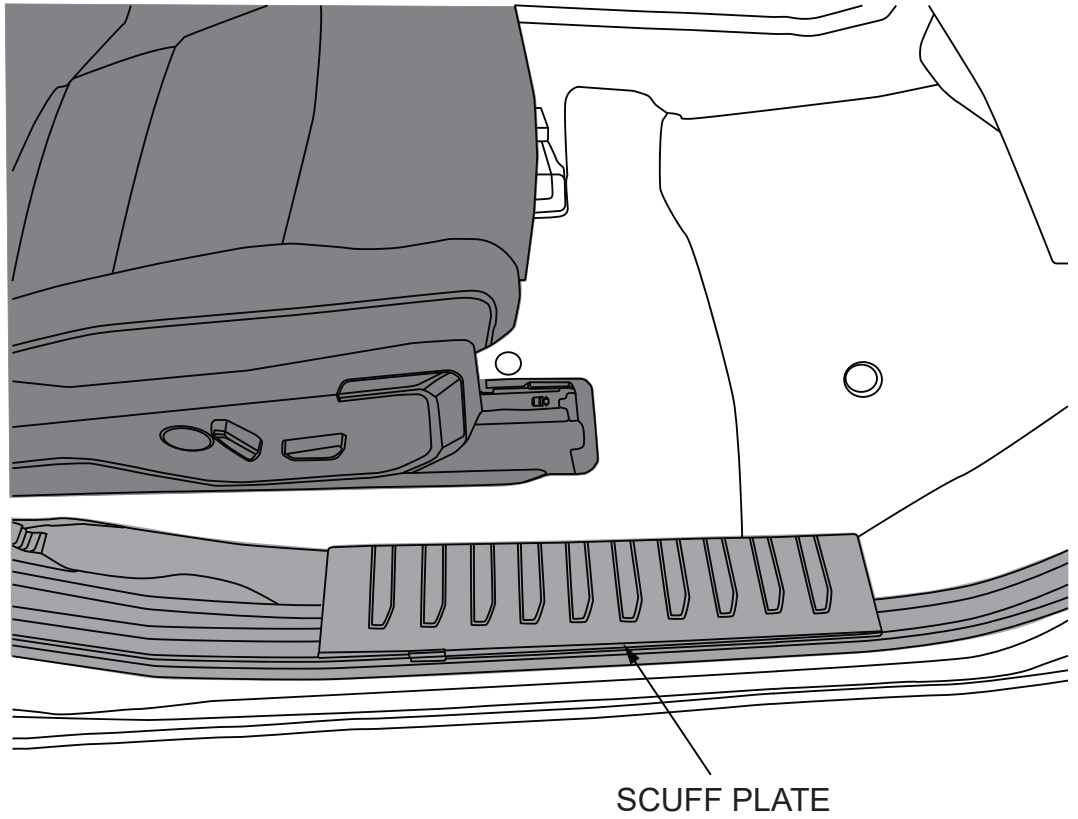

**1** Remove the RHS front scuff plate as shown.

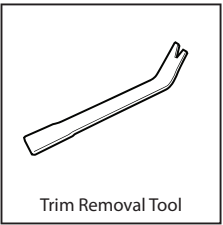

RHS

TRIM COVER

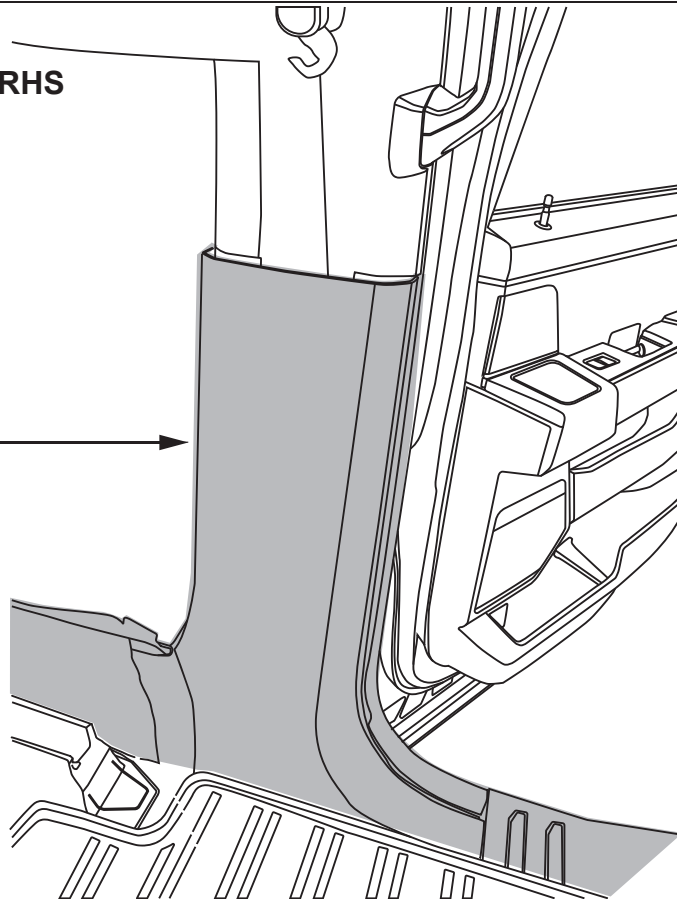

**2** Remove the RHS B-pillar trim cover as shown.

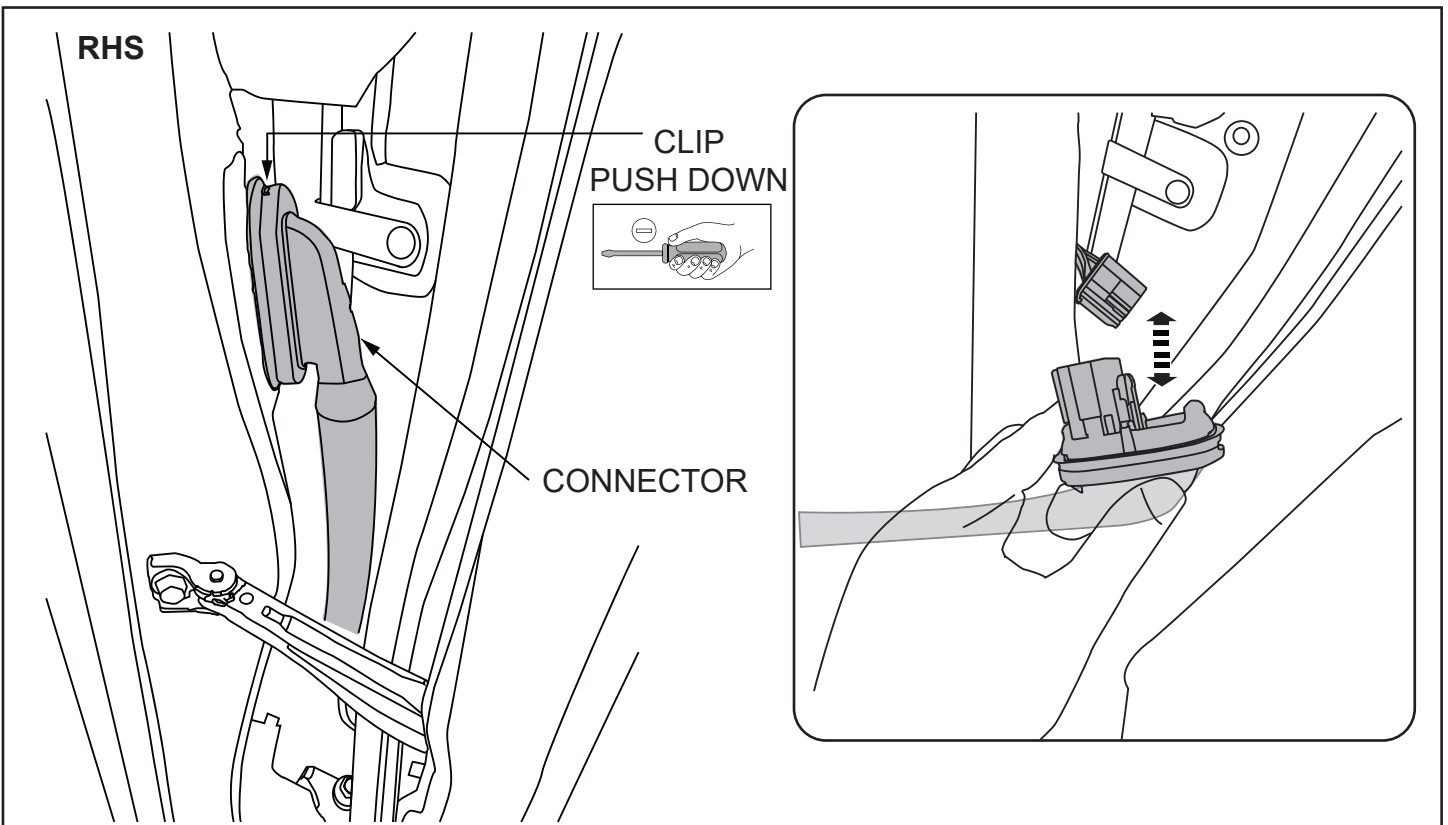

**3** Locate the connector on the outside of the B-pillar and disconnect as shown.

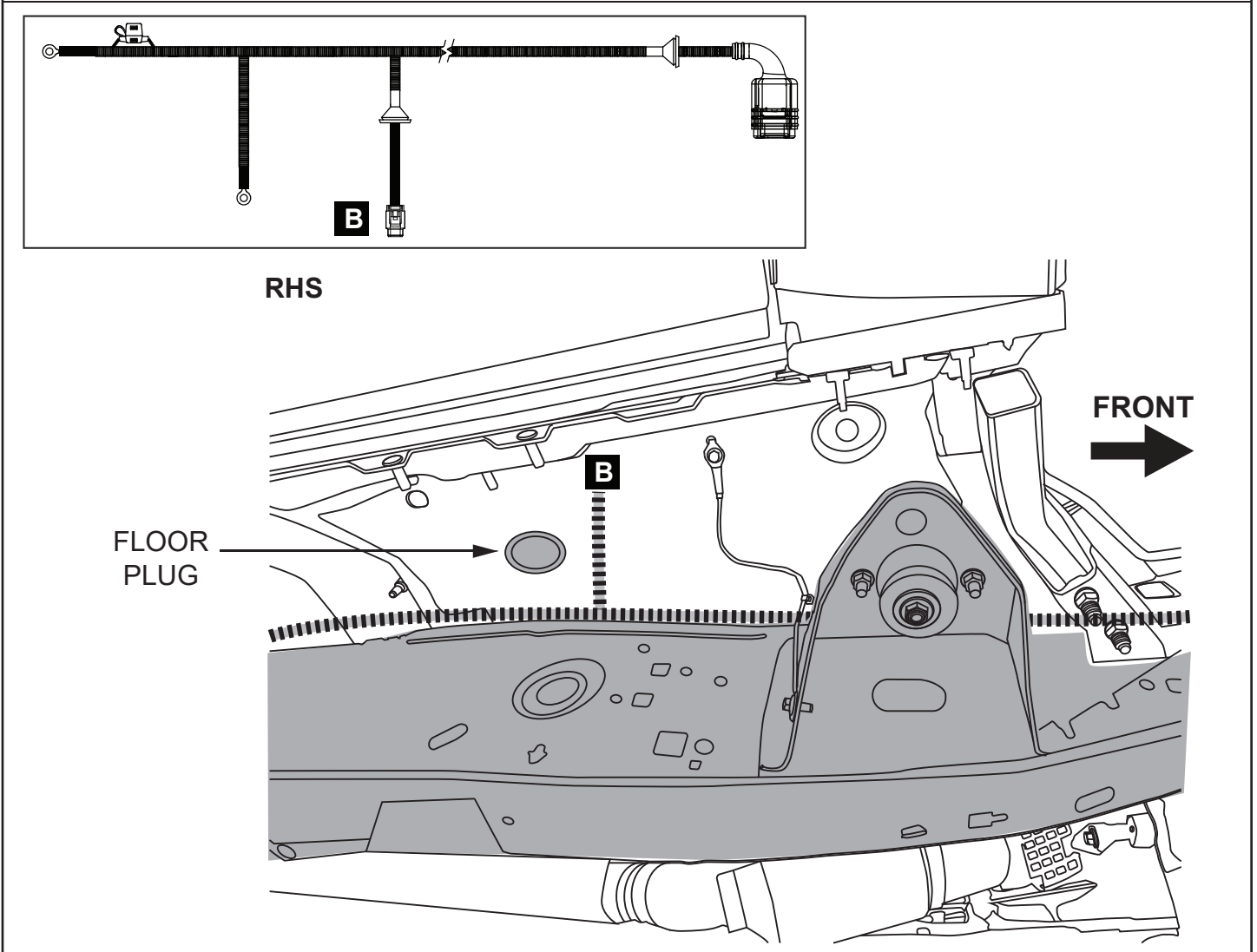

**4** Locate the rubber floor plug on the front RHS of the vehicle as shown. Remove the plug and feed the B-connector from the main harness to the inside of the cabin.

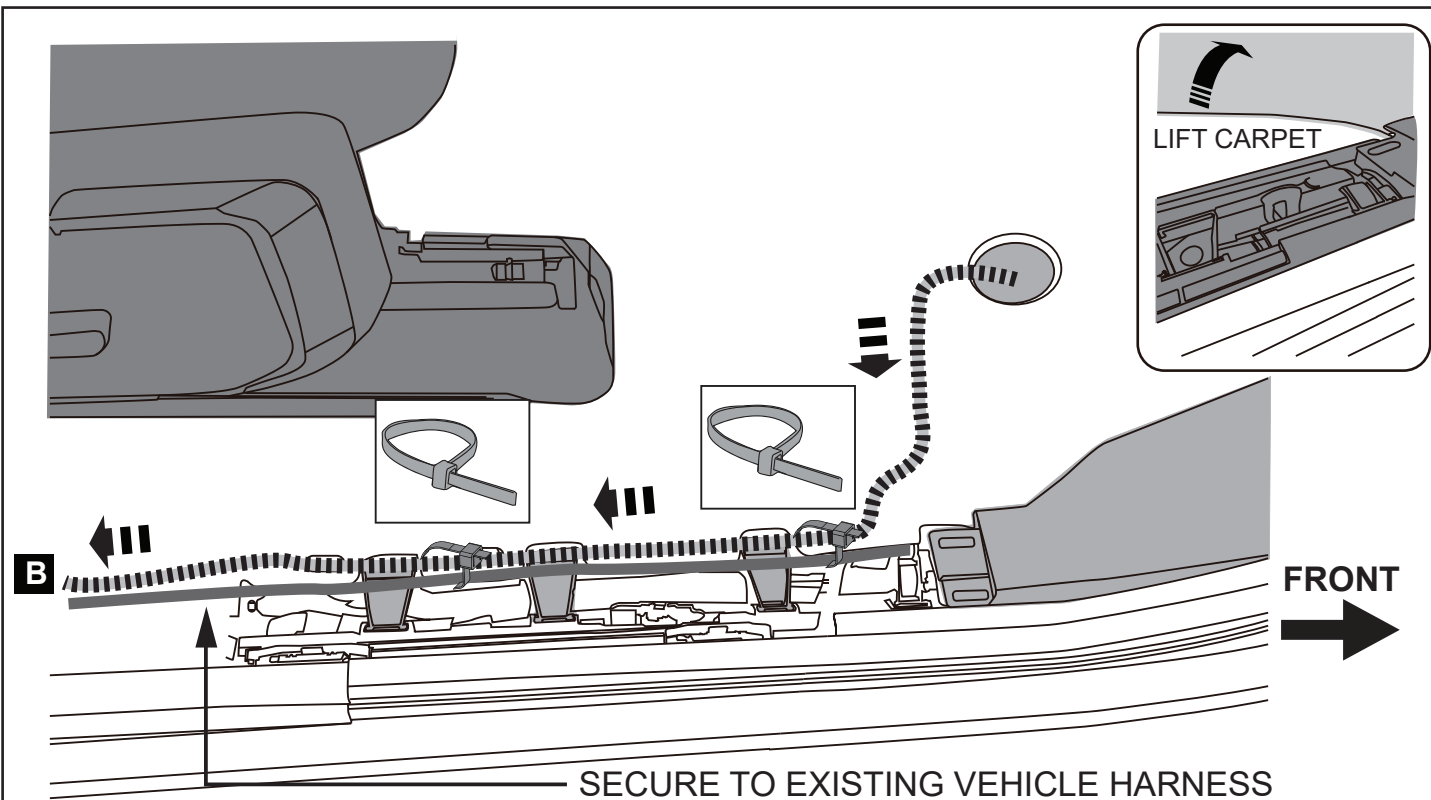

**5** On the front RHS lift up the carpet and pull in the vehicle harness connector B inside the foot well until the rubber grommet on the harness is secured in the floor hole. Feed the harness towards the rear to the B-pillar as shown.

**IMPORTANT:**  
**FOR 2018-19 VEHICLES (INCLUDING RAPTOR) FEMALE CONNECTOR ON THE T-PATCH (E) NEEDS TO BE MODIFIED TO FIT THE VEHICLE HARNESS CONNECTOR (SEE DETAIL)**

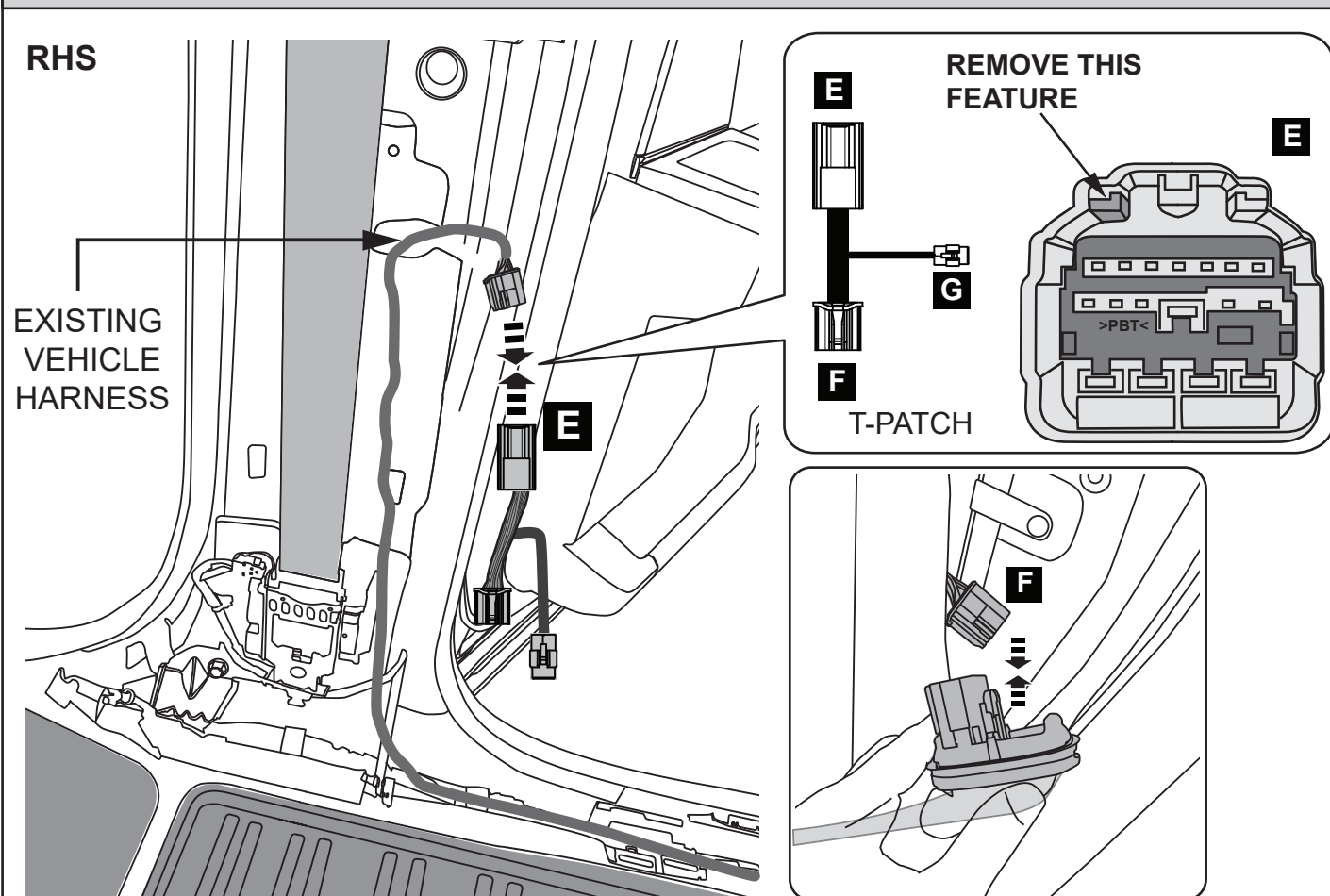

**6** Inside the vehicle connect the previously disconnected connector inside the B-pillar to the (E) connector from the T-patch. Feed the T-patch connector F to the outside of the B-pillar and connect to the previously disconnected harness in step 3 as shown in detail.



# IMPORTANT



## EGR *ROLLTRAC*

### BULLETIN SPlice WIRING DIAGRAM

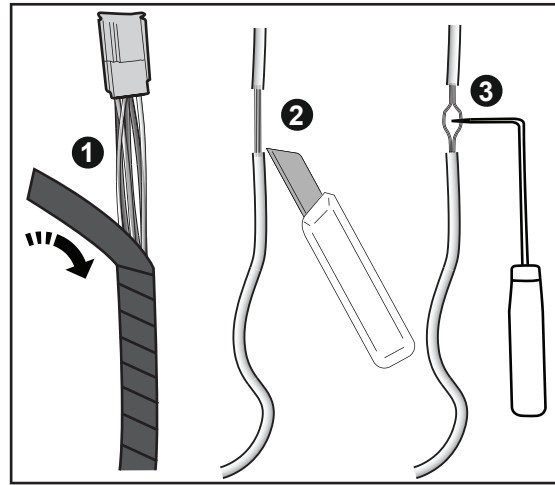
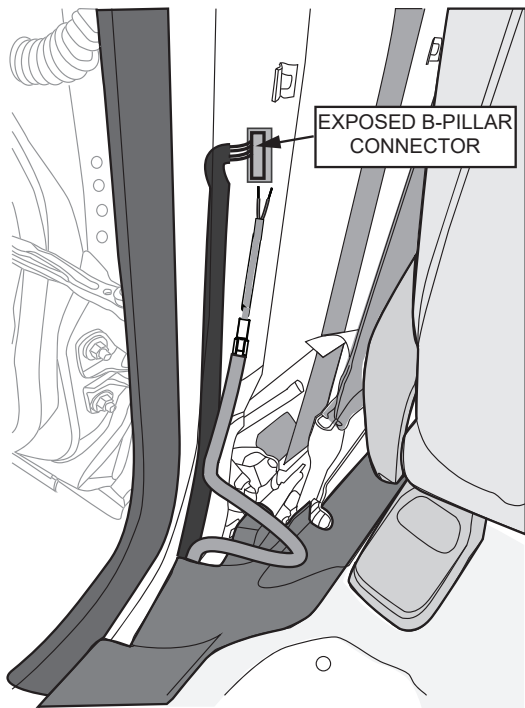

Locate the B-pillar harness plug and select the wires from the factory wiring which relates to your year Model (see below Table). Strip 0.5inch to expose copper as shown. Feed the Rolltrac vehicle harness up to the exposed wires on the B-pillar

#### MY16-23 Models

LOOM UNIT	B-PILLAR HARNESS
ORANGE	GREY/BROWN PIN-13
BROWN	BROWN/GREEN PIN-12

#### MY24-onwards Models

LOOM UNIT	B-PILLAR HARNESS
ORANGE	GREY PIN5
BROWN	GRAY/VIOLET PIN6

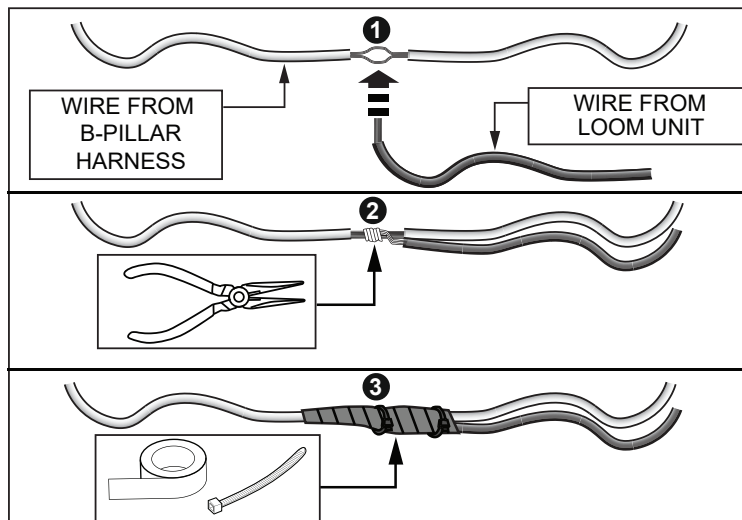

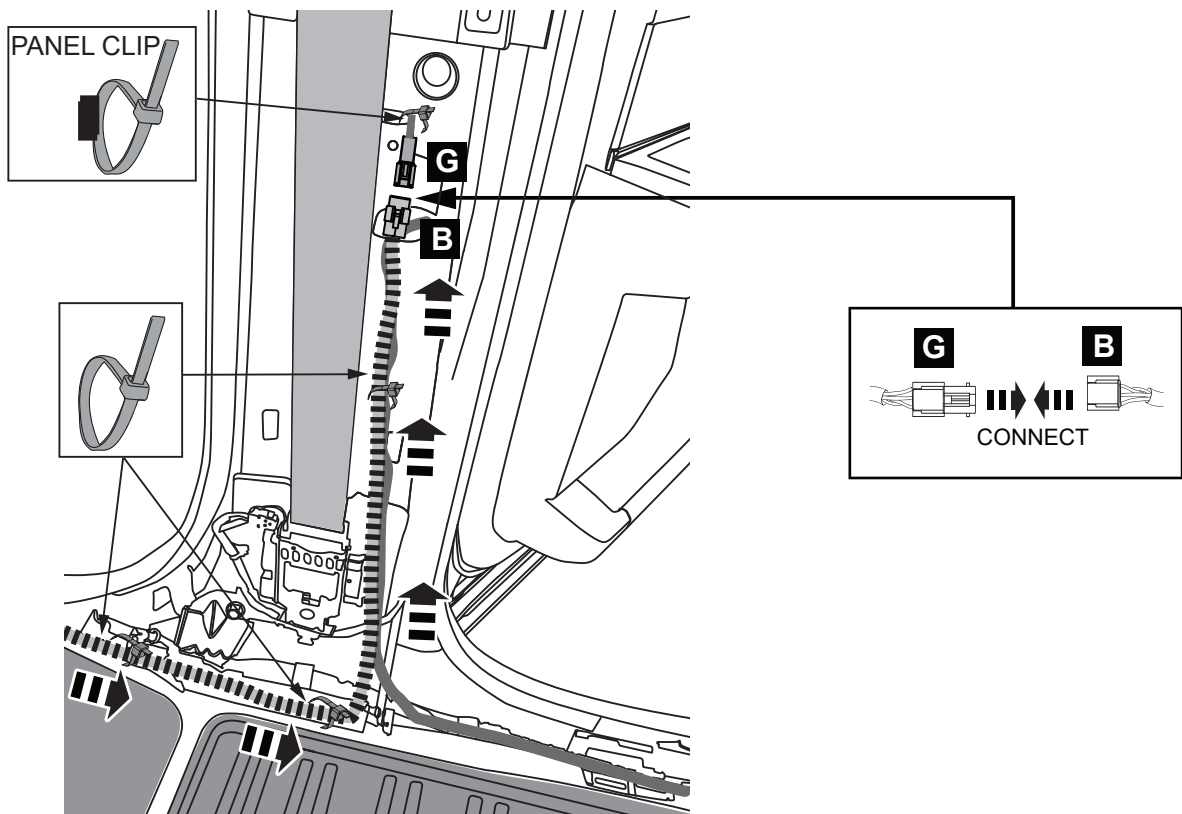

- 7** Run the harness connector (B) along the floor and up to the T-Patch and connect to the (G) connector joining T-patch and Rolltrac harness as shown.  
**IMPORTANT:** Secure the harness by using cable ties to the original vehicle harness and panel clip cable tie to the body on the B-pillar to keep away from the seat belt retractor. Test seat belt before and after refitting the panels. Refit the middle panel and kick panel with the scuff plate to the vehicle.

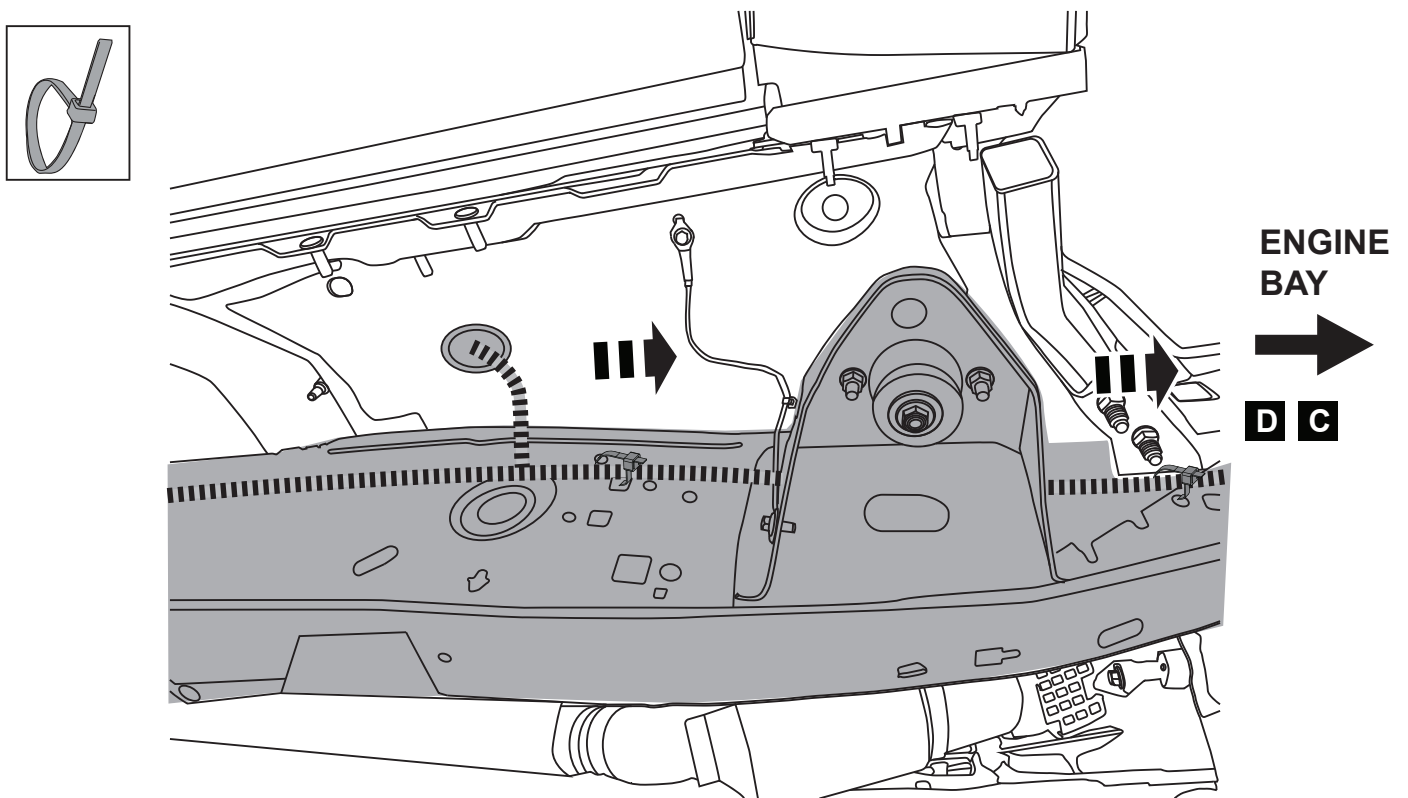

- 8** From underneath the vehicle, route the Vehicle Harness terminals (D&C) towards the front of the vehicle, following outside the chassis rail. Use the supplied cable ties and retain the vehicle harness every 200mm (8") to the chassis rail using holes already present on the chassis rail.

## F150 GAS ONLY MODEL BATTERY CONNECTION STEPS

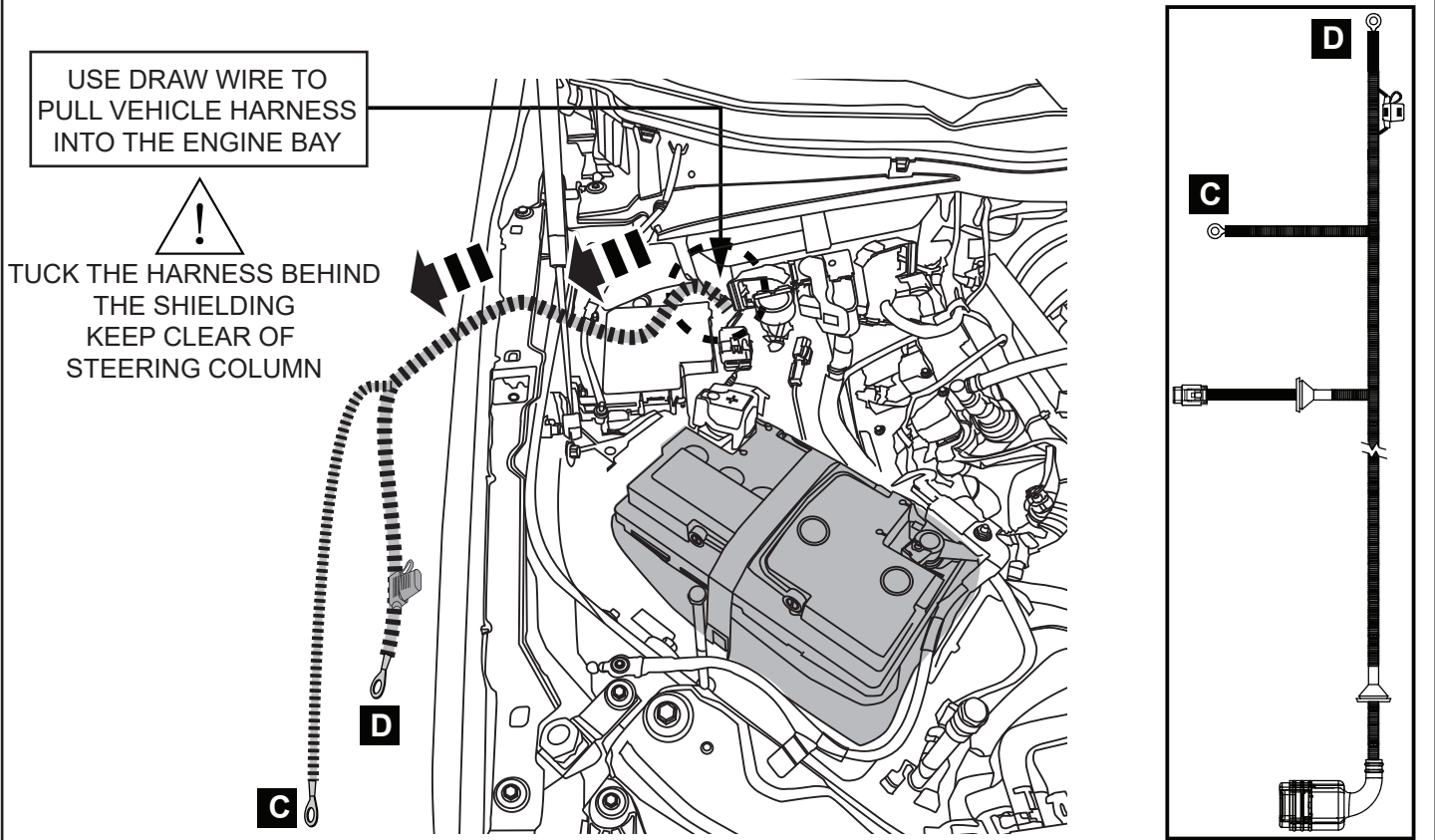

- 9** Feed the harness into the engine bay along the RHS fire wall from underneath the vehicle. Use draw wire first by pushing it down from the engine bay behind the fuse box as shown. Attach the two main harness terminals (D&C) using tape and pull gently into the engine bay. **IMPORTANT:** Make sure fuses are not fitted before making connection.

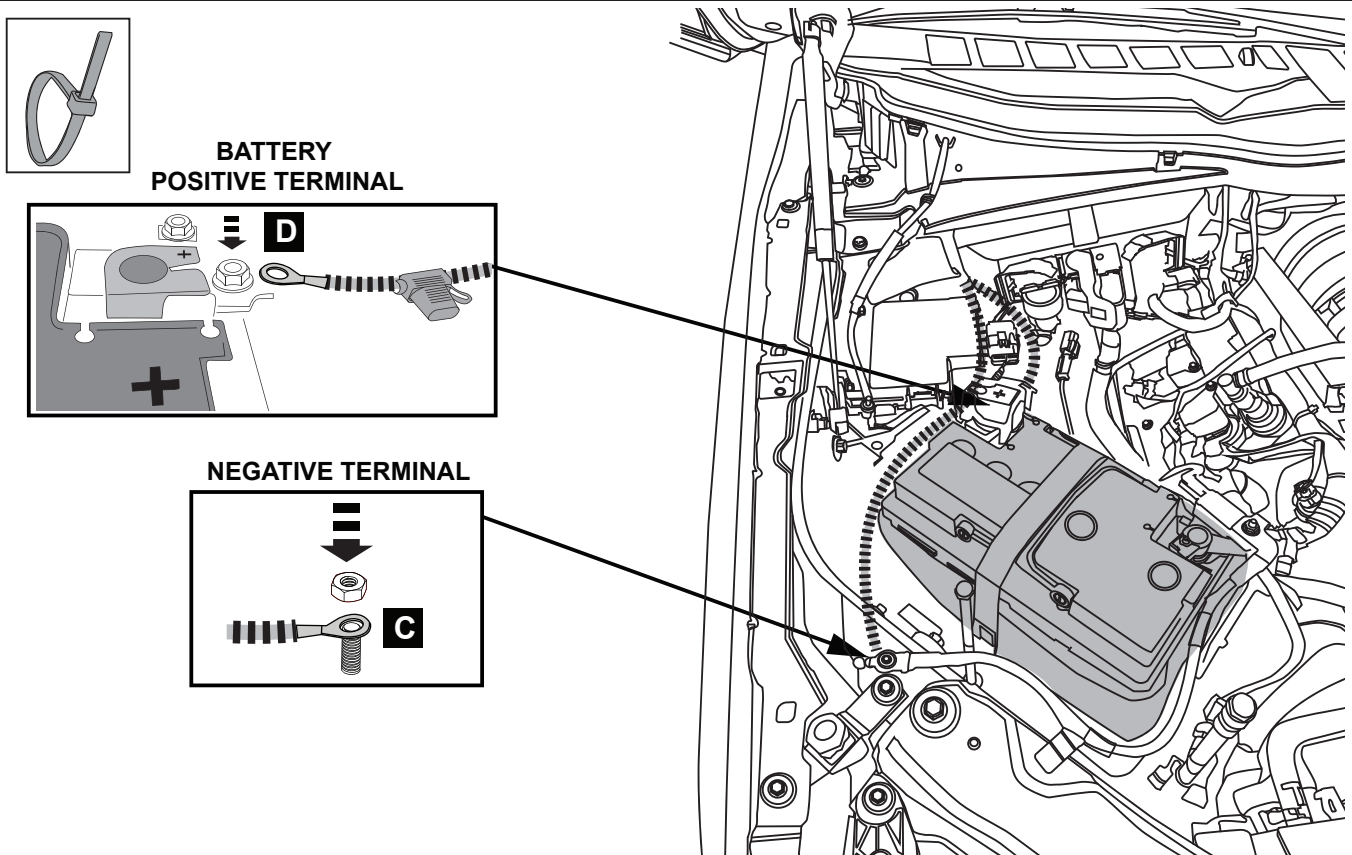

- 10** Connect the vehicle harness branch (C) to vehicle body negative ground, located in the engine bay as shown. Once it is positioned, secure in place using cable ties. Connect the vehicle harness branch (D) to the positive terminal of the battery. Once it is positioned, secure in place using cable ties. **NOTE:** ensure fuses are not fitted to the harness.

**Continue to step 11.**

## F150 LIGHTING EV MODEL BATTERY CONNECTION STEPS

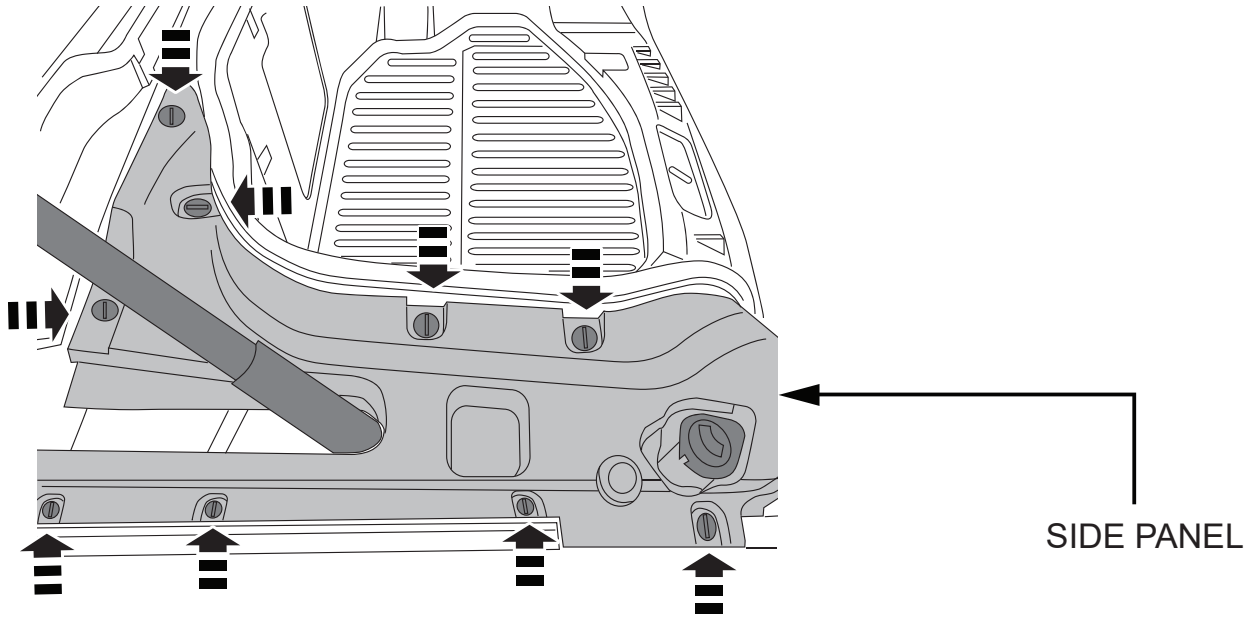

**A** Remove front drivers side panel. All fixings can be released without the use of tools as shown.

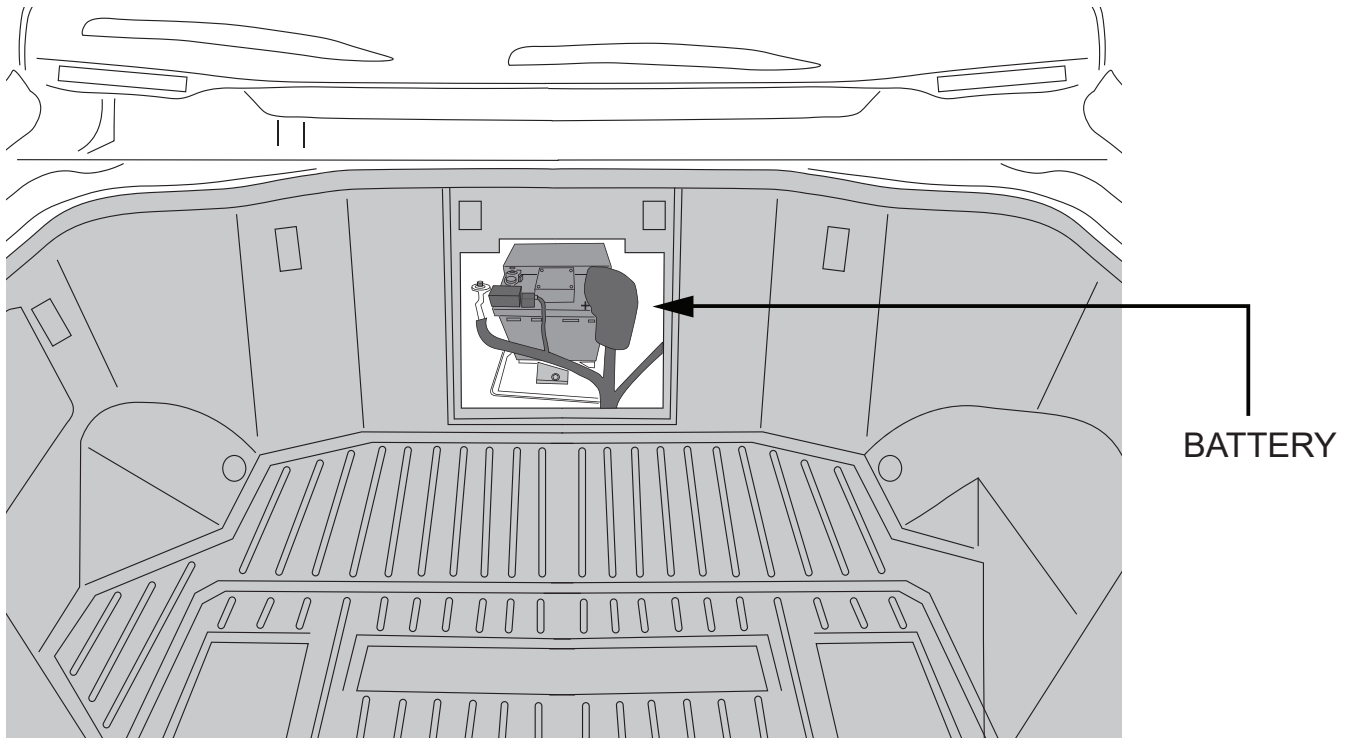

**B** In the trunk, remove the battery cover to gain access to the positive terminal.

## F150 LIGHTING EV MODEL BATTERY CONNECTION STEPS

USE DRAW WIRE TO  
PULL VEHICLE HARNESS  
INTO THE ENGINE BAY

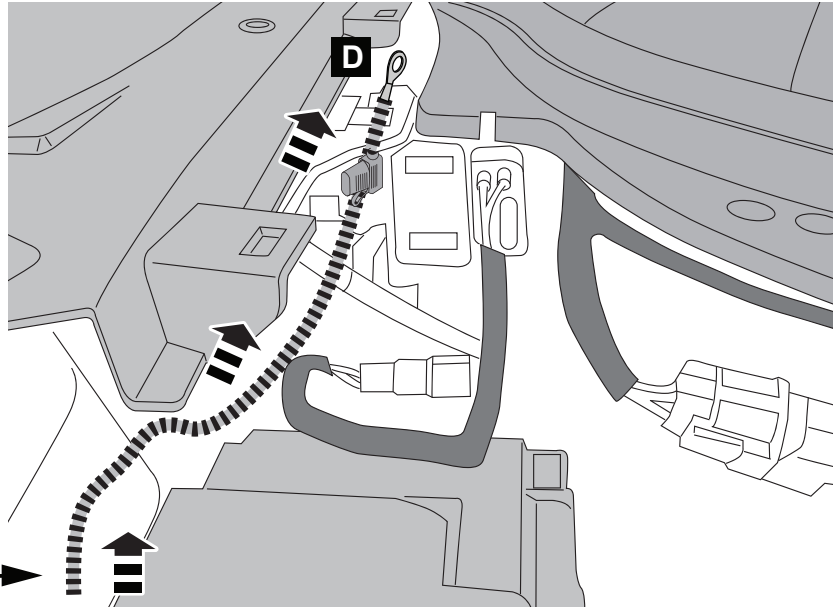

- C** Feed the harness into the trunk along the RHS fire wall from underneath the vehicle. Use draw wire first by pushing it down from the trunk. Attach the harness terminals (D) using tape and pull gently into the trunk. Run the harness along the top towards the battery as shown.

**IMPORTANT:** Make sure the fuse is not fitted before making final connection.

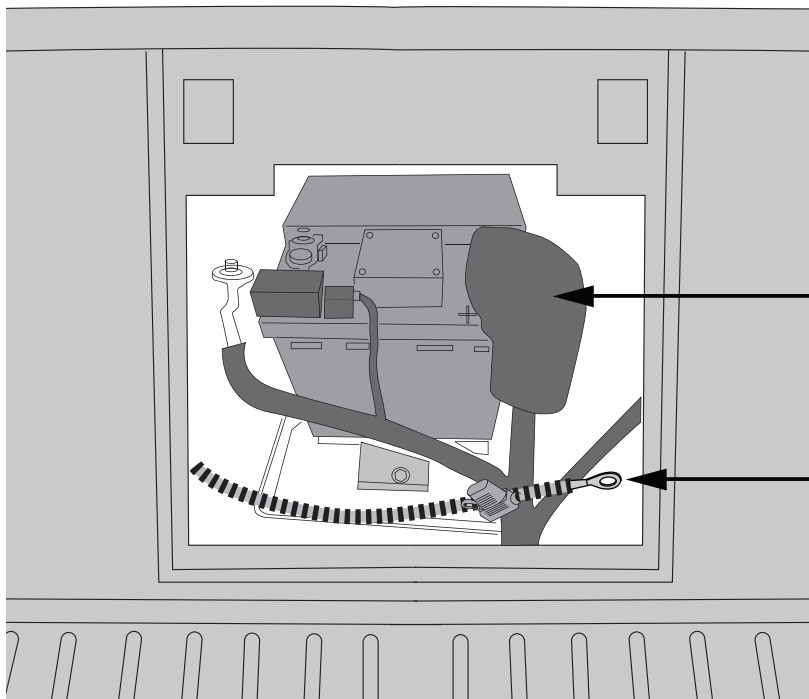

- D** Connect the vehicle harness branch (D) to the positive terminal of the battery. Once it is positioned, secure in place using cable ties. **NOTE:** ensure the fuse is not fitted to the harness.

**Continue to step 11.**

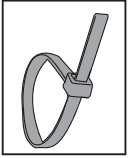

REAR  
←

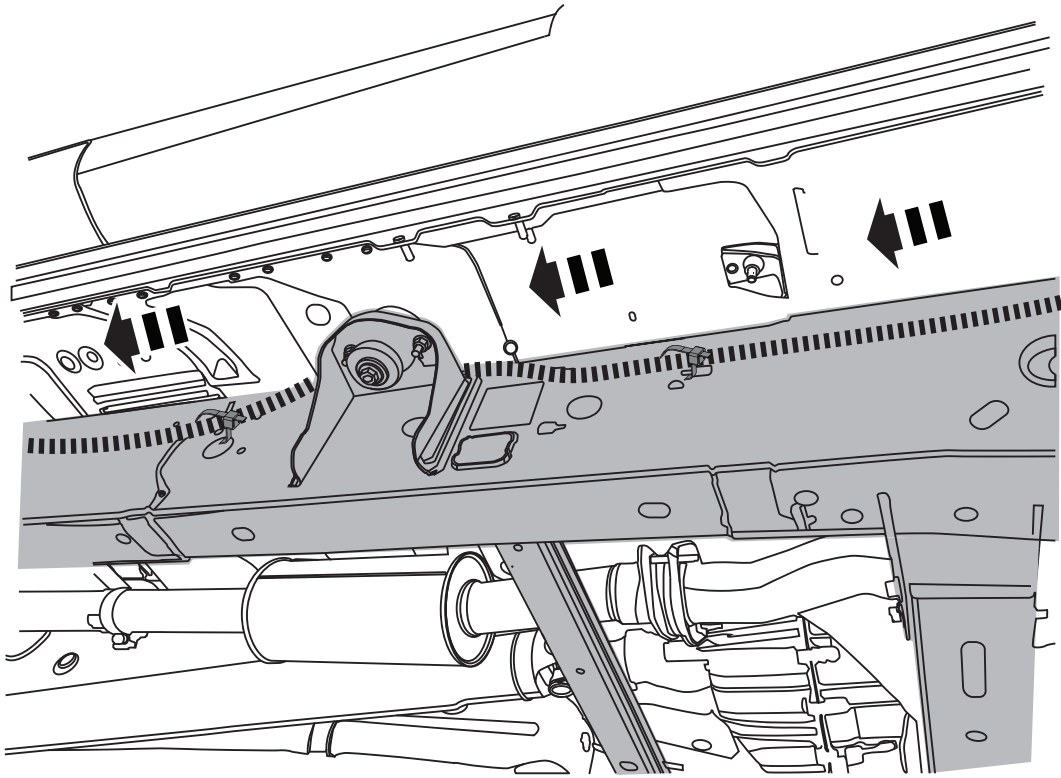

- 11** From underneath the vehicle, route the Vehicle Harness connector A towards the rear of the vehicle, following outside the chassis rail. Use the supplied cable ties and retain the harness every 200mm (8") to the chassis rail using holes already present on the chassis rail.

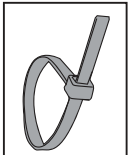

REAR  
←

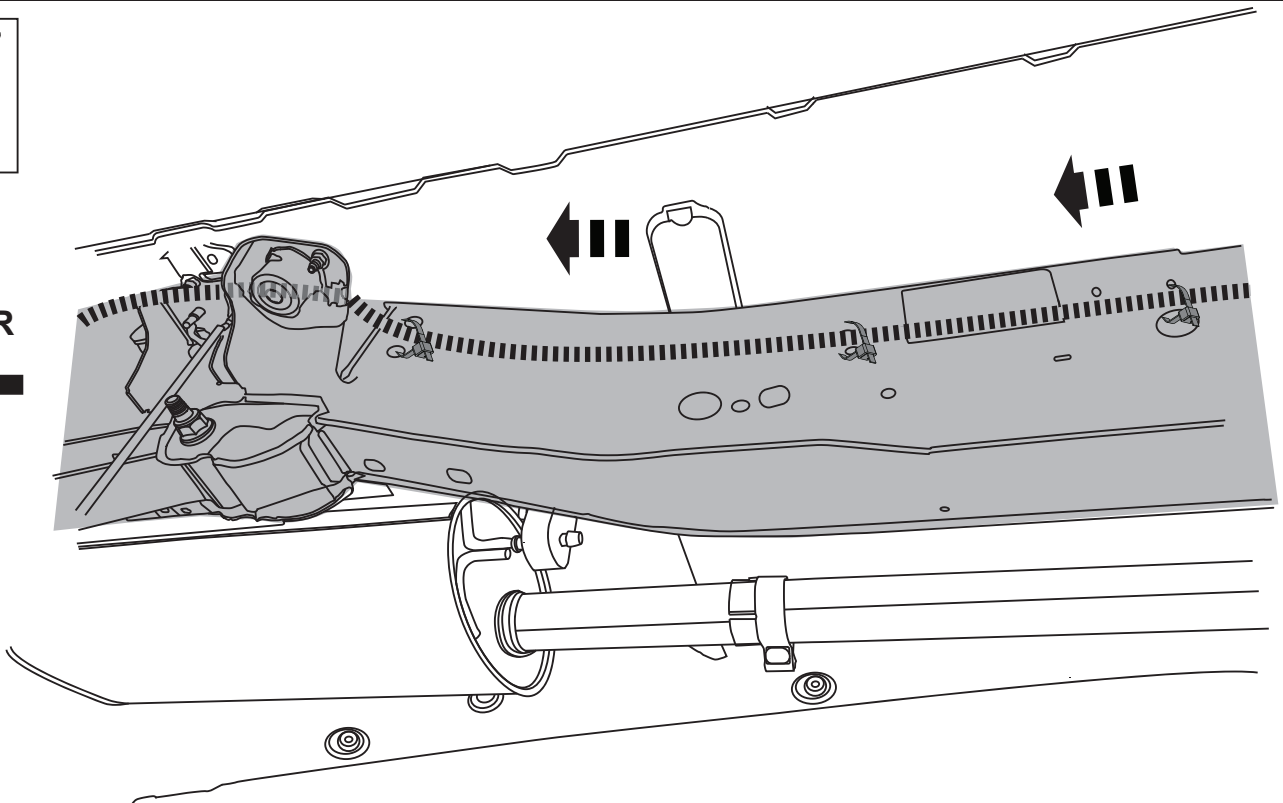

- 12** From underneath the vehicle, route the Vehicle Harness connector A towards the rear of the vehicle, following outside the chassis rail. Use the supplied cable ties and retain the harness every 200mm (8") to the chassis rail using holes already present on the chassis rail.

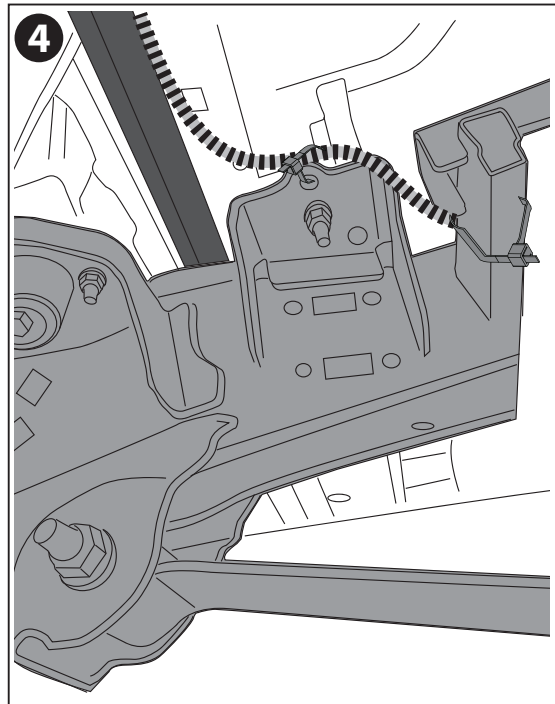
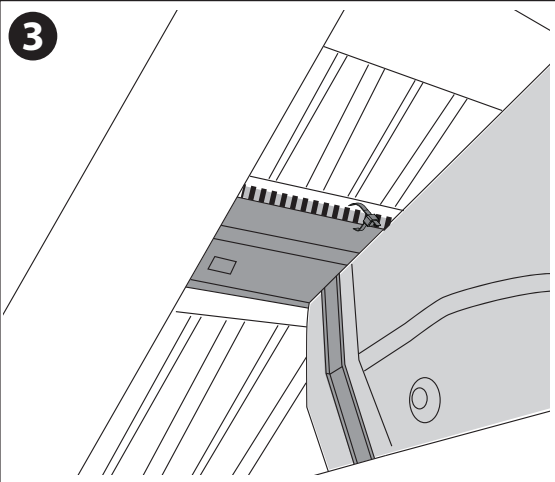
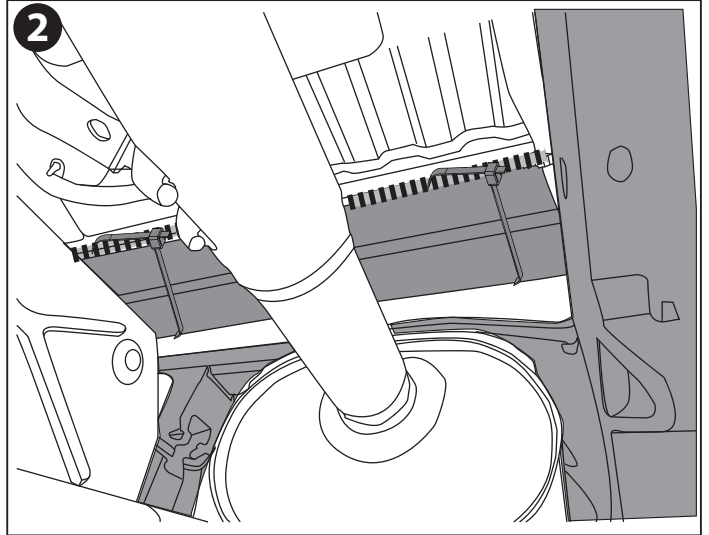
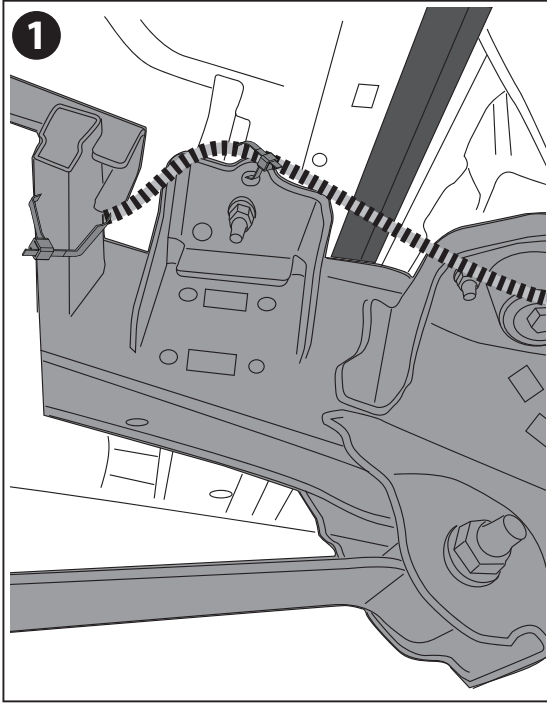

**13** Run the vehicle harness to the cross beam as shown in detail (1). Use long zip tie to secure it. Follow the cross beam to the other side of the vehicle. Keep the harness on top of the beam and away from the muffler and moving parts. Zip tie near the muffler as shown in detail (2). Near the fuel tank secure to the existing harness (3). At the end of the cross beam, use long zip tie and small one as shown in detail (4).

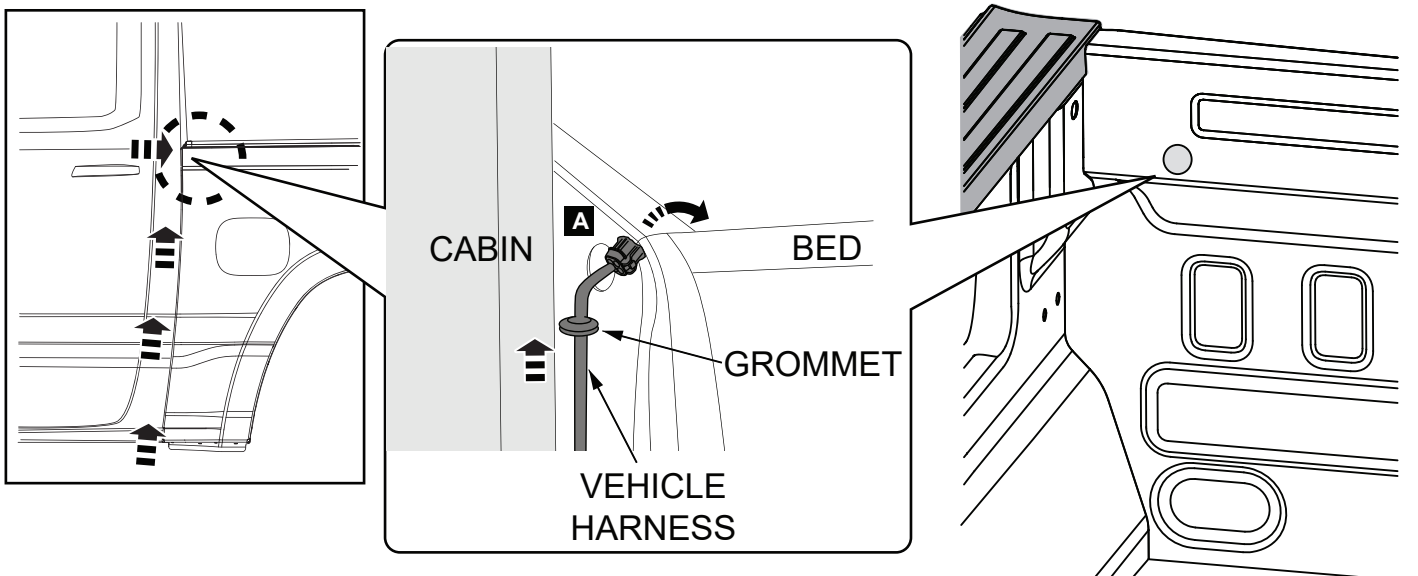

**14** After securing the harness, pull up the connector (A) between the cabin and the truck bed into the previously drilled hole in the front LHS of the bed, until the rubber grommet sits firmly in the hole.



# IMPORTANT



## **EGR** *ROLLTRAC*

### BULLETIN HAND RAIL ATTACHMENT

#### PARTS:

**1**

Hand Rail  
QTY-1

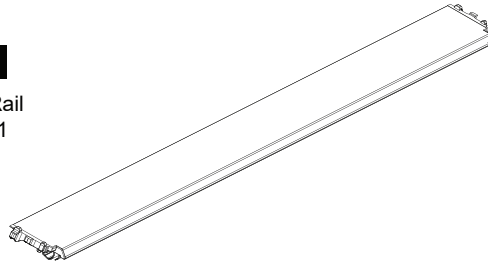

#### INSTALLATION STEP:

Place hand rail onto slat assembly by turning approximately 45 degrees down and inserting it as shown.

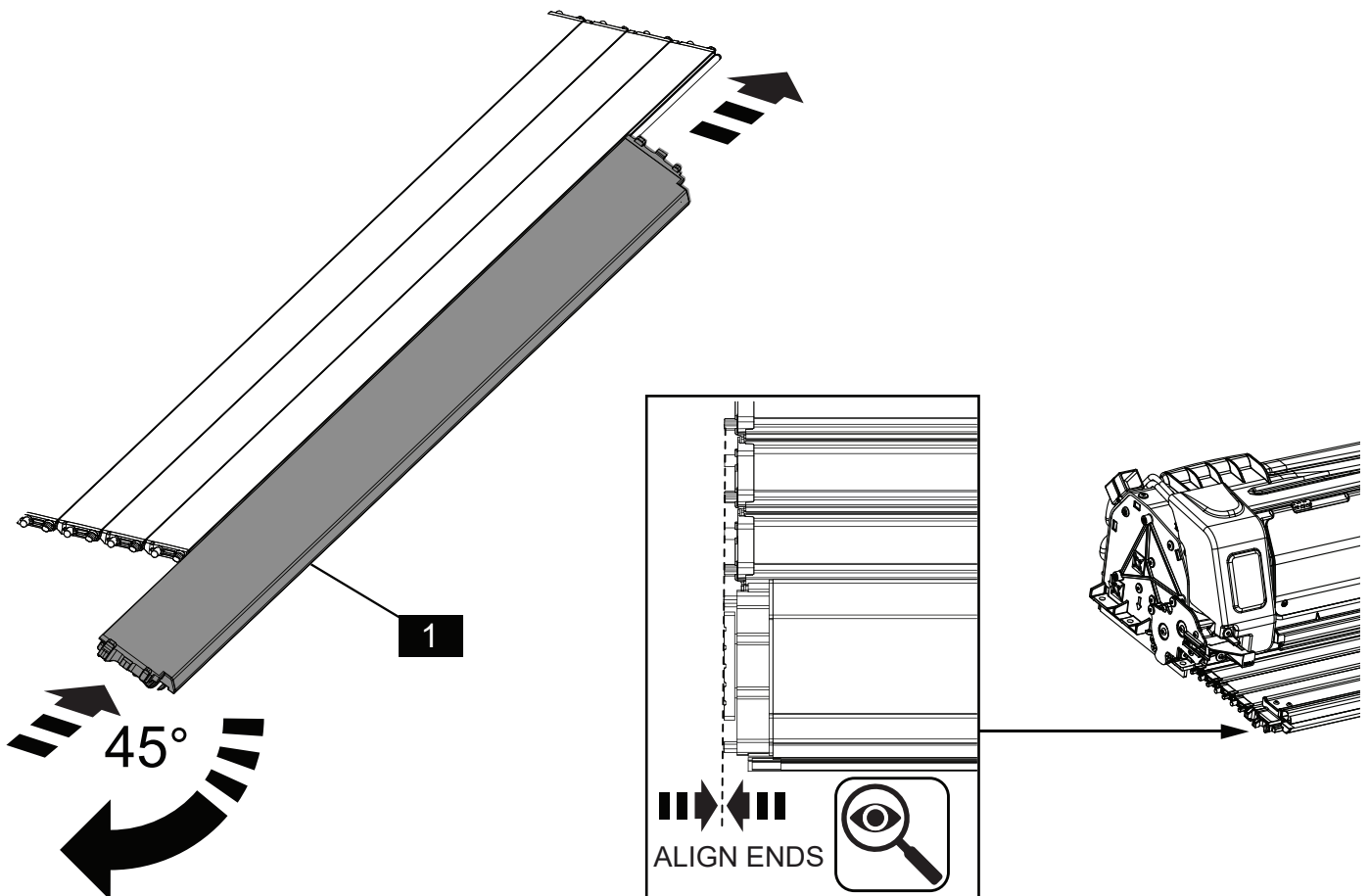



DURING ASSEMBLY PROCEDURE SUPPORT AT CENTER OF CANISTER ONLY, PLACE ON TOP AND BASE CARTON (OR SIMILAR), COVER WITH FOAM BLANKET. TO AVOID SCRATCHING POWDERCOATED SURFACES. DO NOT LOAD ELECTRICAL CONNECTORS OR MOTOR COVER.

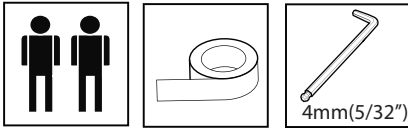

**! FIT RHS FIRST**

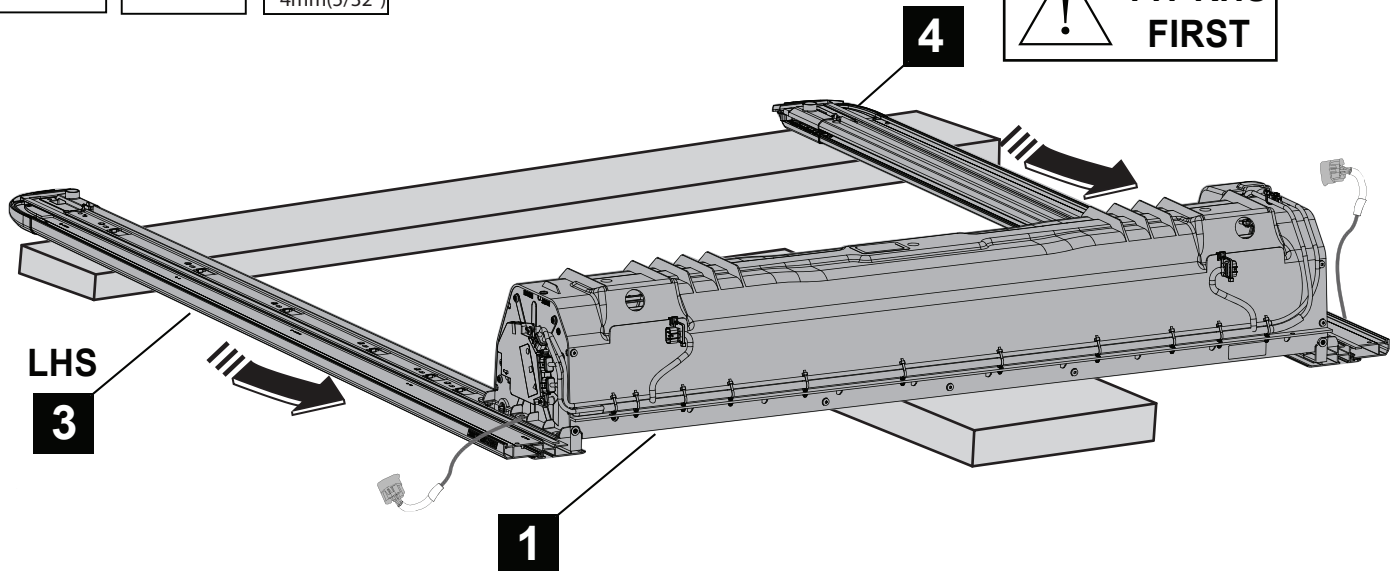

**1** **! ATTENTION: SEAL MUST FACE IN THE DIRECTION AS SHOWN. WARRANTY VOID IF ASSEMBLED INCORRECTLY.**

HOLD SEAL FLAT USE CLOTH TAPE

**RHS SHOWN**

**2** **! ATTENTION: EXPOSE 3 SLATS PRIOR TO FITTING SIDE RAILS.**

ENSURE ENDS ARE ALIGNED

**! ATTENTION: WIPE THE SEAL AND SIDE RAIL WITH WAX & GREASE REMOVAL TO ENSURE THE CLOTH TAPE WILL ADHERE TO THE SIDE RAIL AND SEAL**

**1** Place the canister (1) on two protected boxes as shown, ensure hand rail and slat ends are aligned. Tape up the seal on the Side Rail (3) as shown. **IMPORTANT:** Carefully align and slide the rail over the handrail endcap and canister endplate taking particular care to ensure that the siderails are slid straight and no undue force is applied to the electrical contact. Details in following steps.

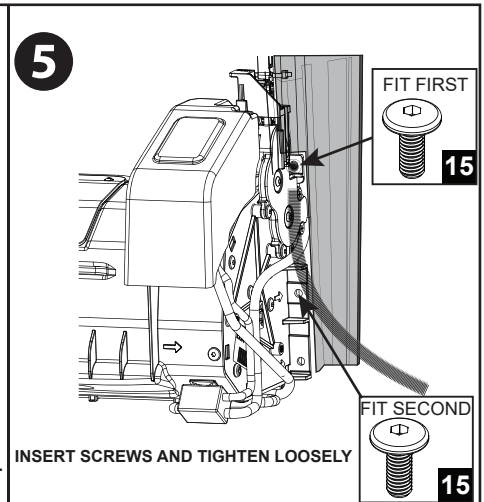
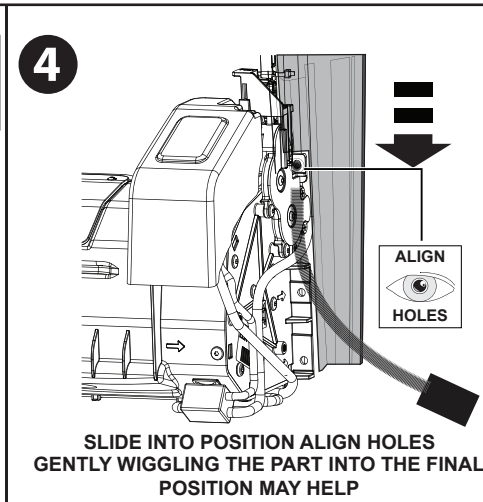
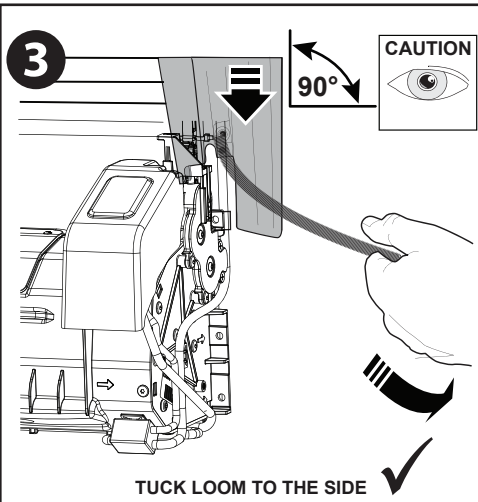

**2** Pull hand rail to expose 3 slats. Slide the RHS Rail over slat ends and onto endcap location pins. Align the holes and secure loosely with two screws (15). Do not tighten. Repeat for LHS Rail (4).

! DURING ASSEMBLY PROCEDURE SUPPORT AT CENTER OF CANISTER ONLY, PLACE ON TOP AND BASE CARTON (OR SIMILAR), COVER WITH FOAM BLANKET. TO AVOID SCRATCHING POWDERCOATED SURFACES. !

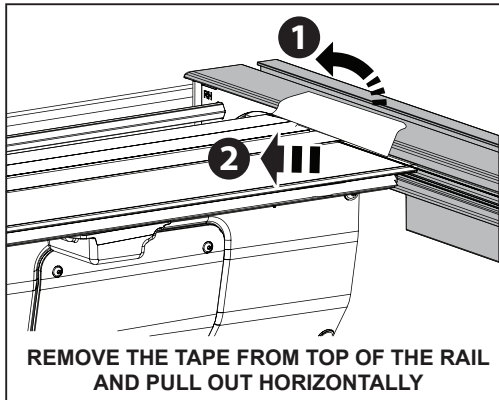
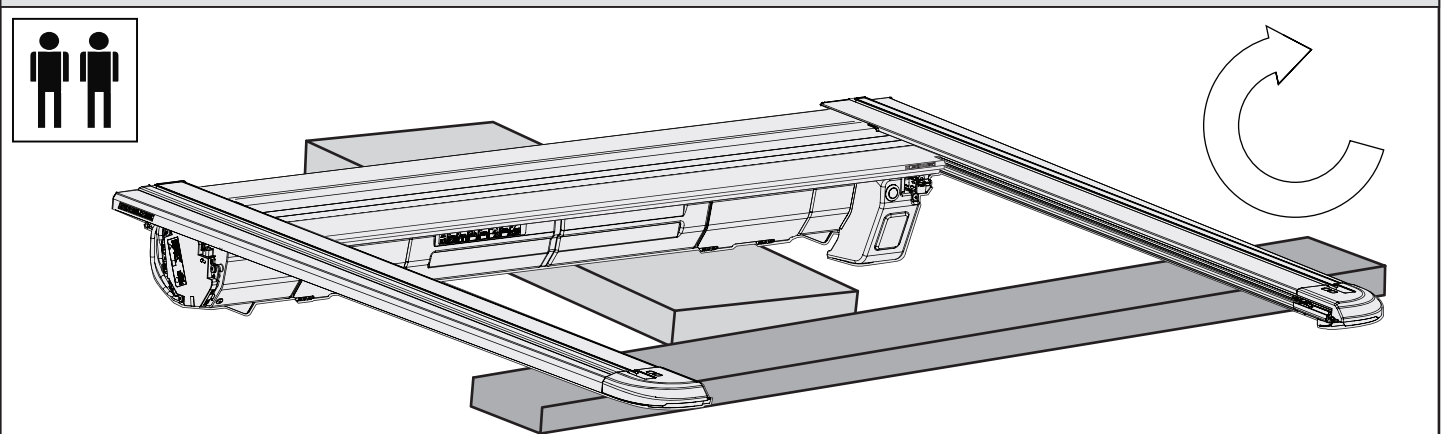

! ATTENTION: SEAL MUST FACE IN THE DIRECTION AS SHOWN. WARRANTY VOID IF ASSEMBLED INCORRECTLY.

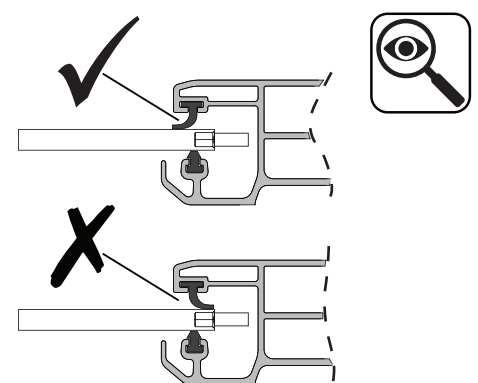
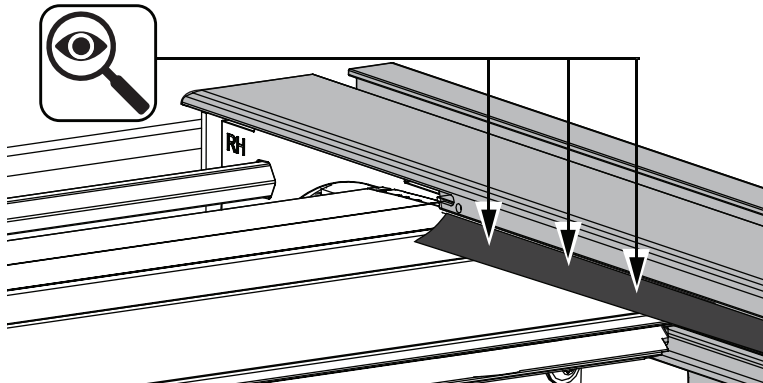

CHECK SEAL IS IN POSITION AND NOT DAMAGED

**3** Carefully turn the assembly over and place onto a protected surface. Remove the tape holding the rubber seal and check the seal position as shown. Repeat for LHS Rail.

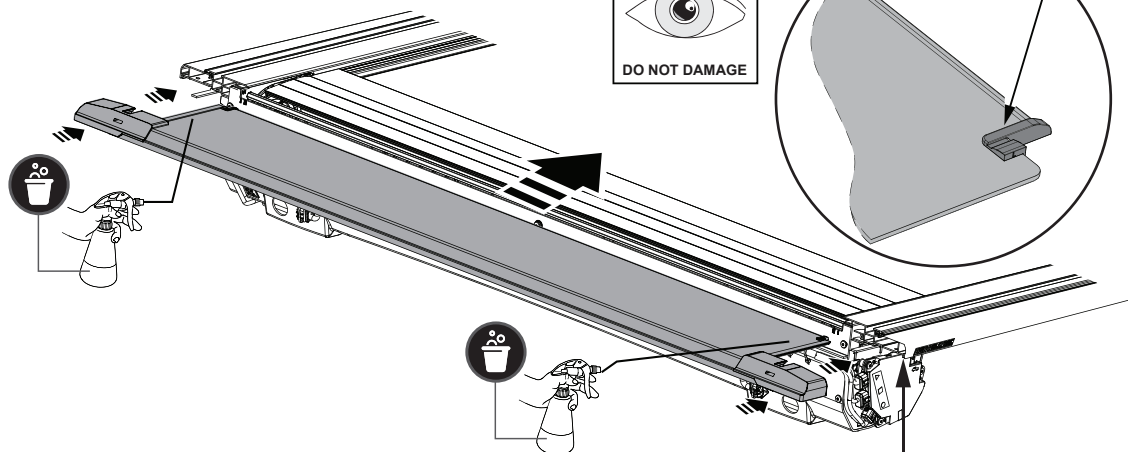

REMOVE TAPE SECURING THE RUBBER CORNER SEAL

**CAUTION**



DO NOT DAMAGE

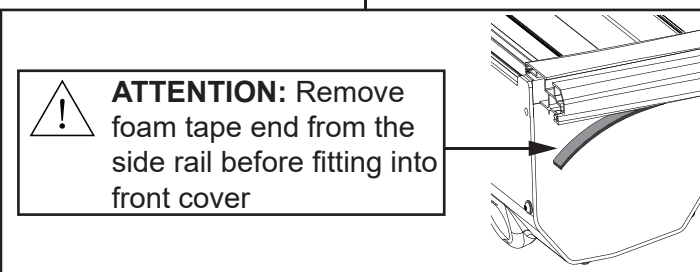

- 4** Slide the Front Plate (2) over the canister and into the side rail channels ensuring that the foam side rail tape is pulled out of side rail and the small rubber corner seal on the RHS and LHS of the front plate are not damaged. **IMPORTANT:** Spray the front cover edge with soapy water to allow it to slide easily into the sides, twisting side rails outwards will also help.

CONTINUE ON THE NEXT PAGE

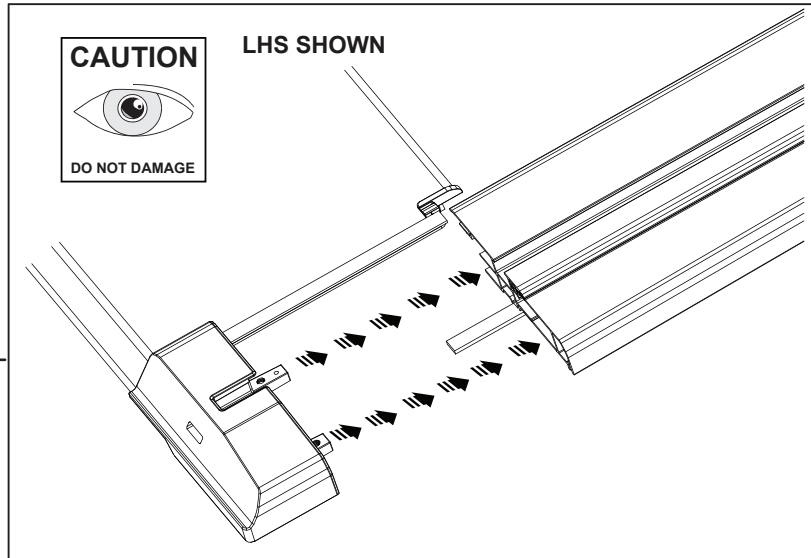
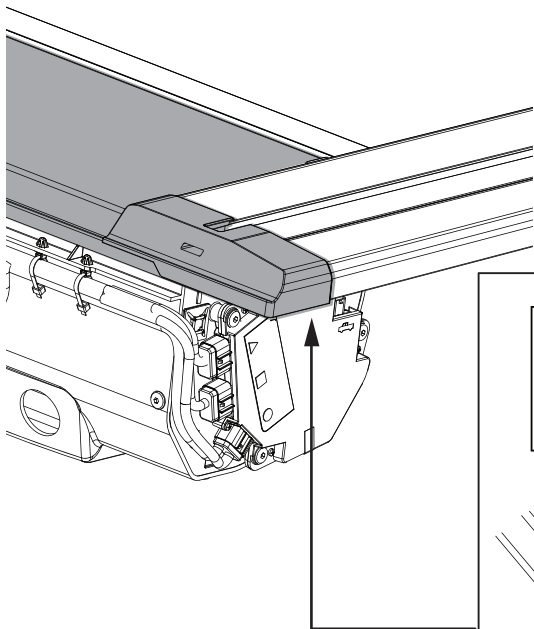

**5** While sliding the front cover ensure the cast connectors are align.

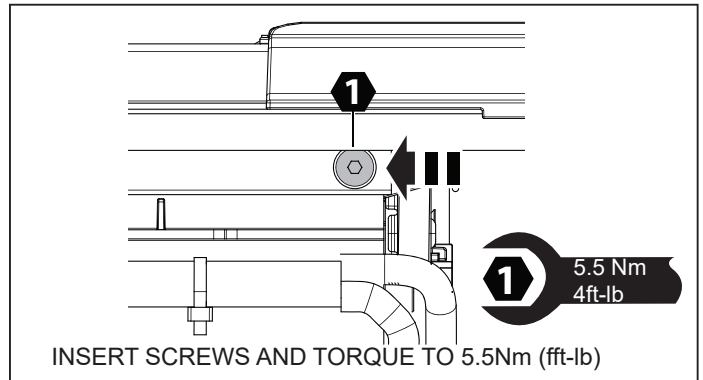
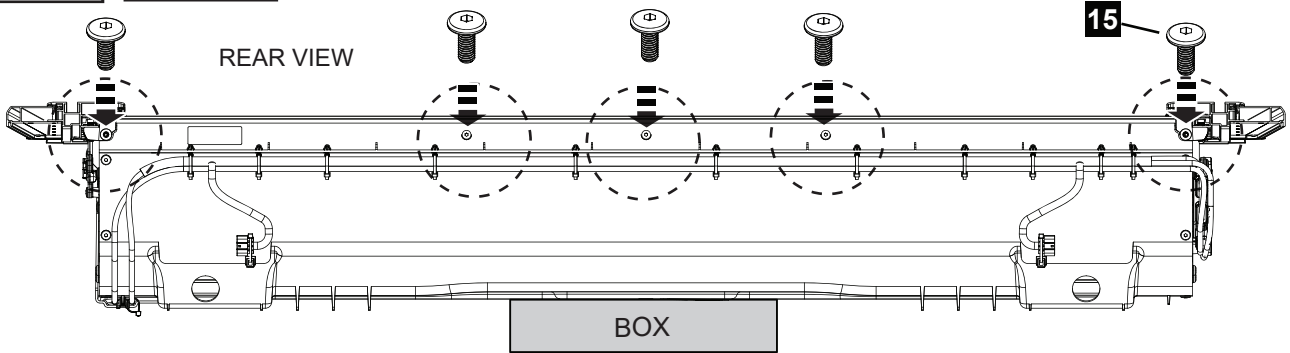
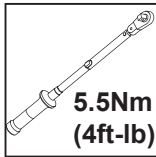
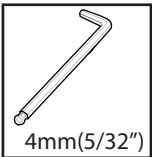

**6** Using 5 screws (15), secure the Front Plate (2) to the Canister Assembly (1) and torque to 5.5Nm (4ft-lb).

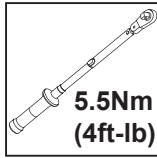
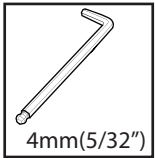

SIDE VIEW

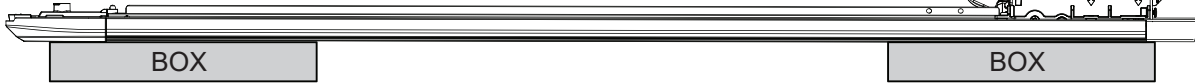

LHS

RHS

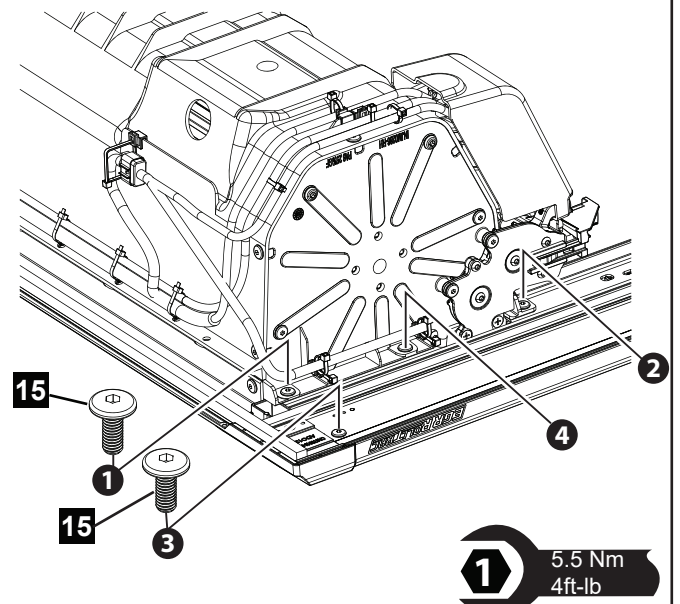
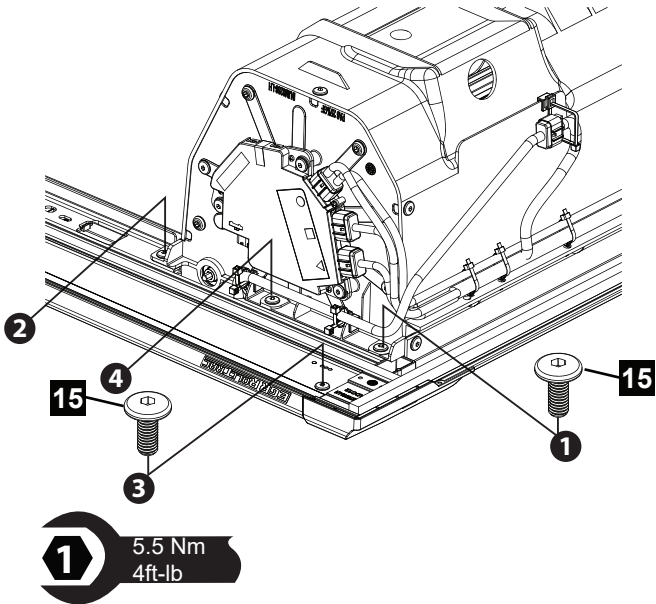

**7** Carefully flip the assembly over onto a flat protected surface which will not damage the cover or scratch the paint work. Install the 2 screws (15) on each side through the canister and side rail into front cover. Torque all screws in order shown to 5.5Nm (4ft-lb).

LHS SHOWN - RHS IS A MIRROR IMAGE

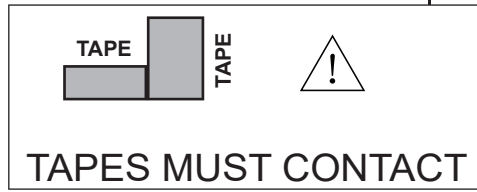
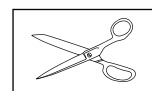
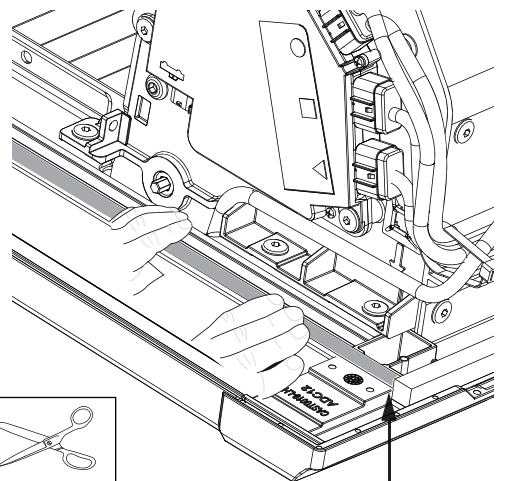
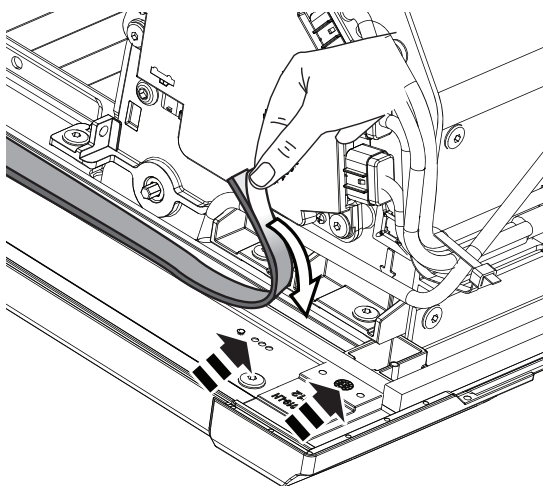

CLEAN WITH ALCOHOL FIRST



**8** Clean powder coated surface first with alcohol spray. Trim foam tape length to ensure the end will butt against front cover seal - avoiding any gap. Peel the protective liner from the foam tape, adhere to the channel in the side rail, Press down firmly to secure. Repeat on RH side rail.

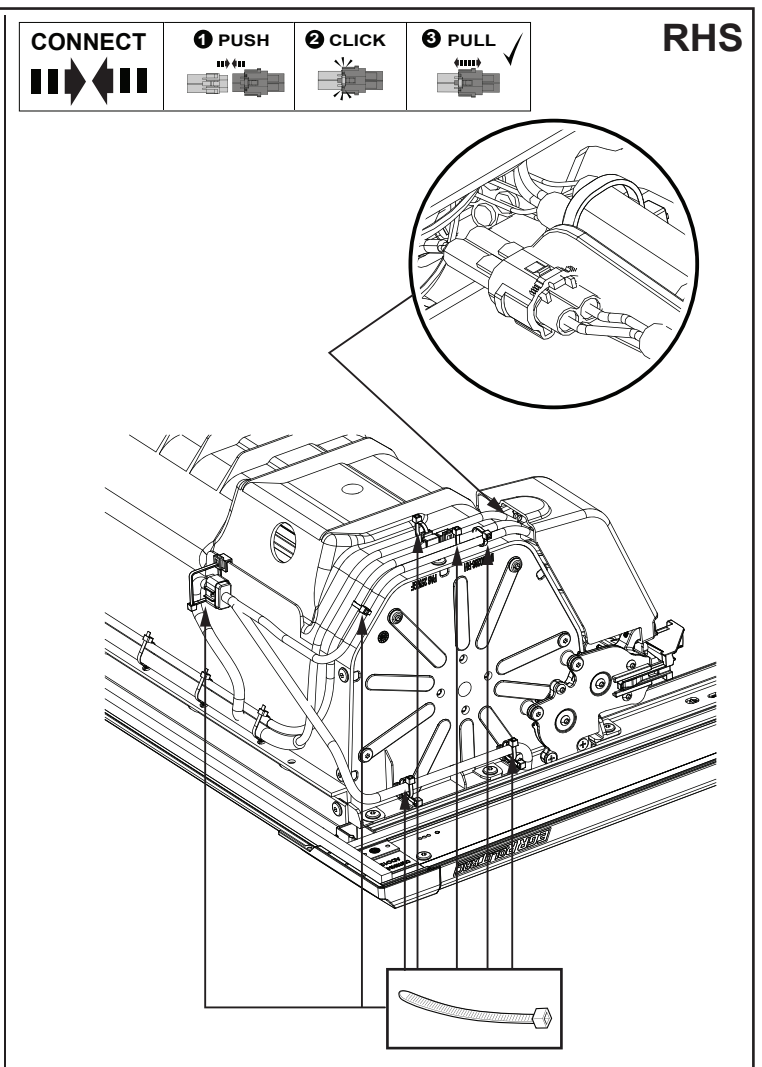
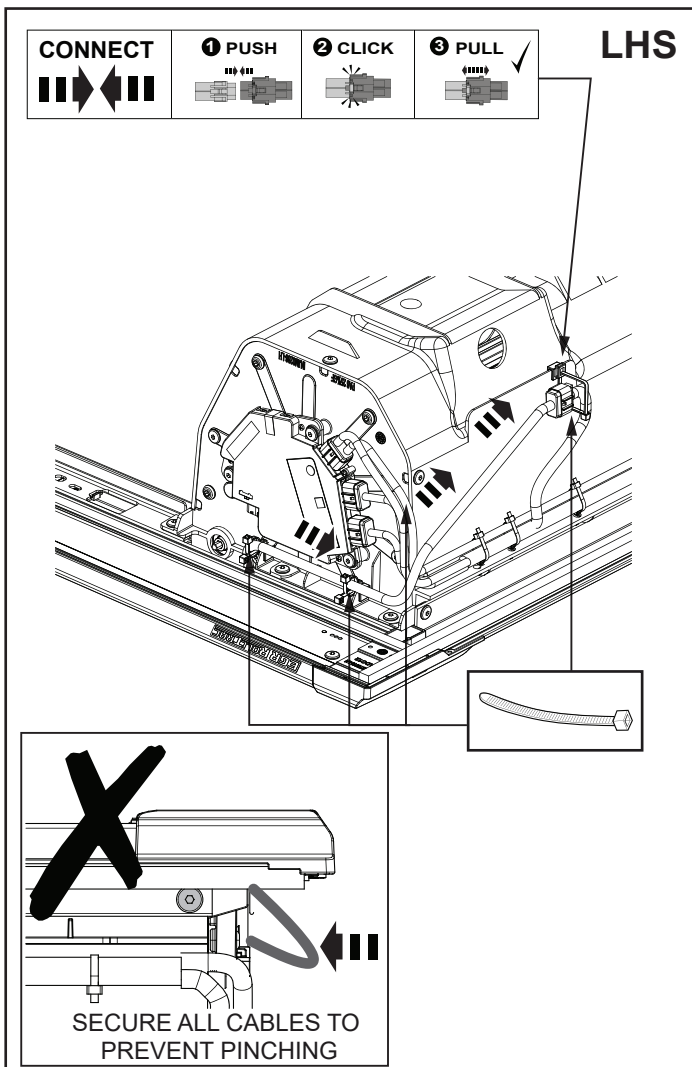

- 9** Connect side rail harness connectors to the connectors on the canister on the LHS and RHS. Connect the lamp connector as shown next to the motor on the RHS. Secure the harness to the canister using cable ties and pads as shown. Ensure all cables are retained to prevent pinching during installation.

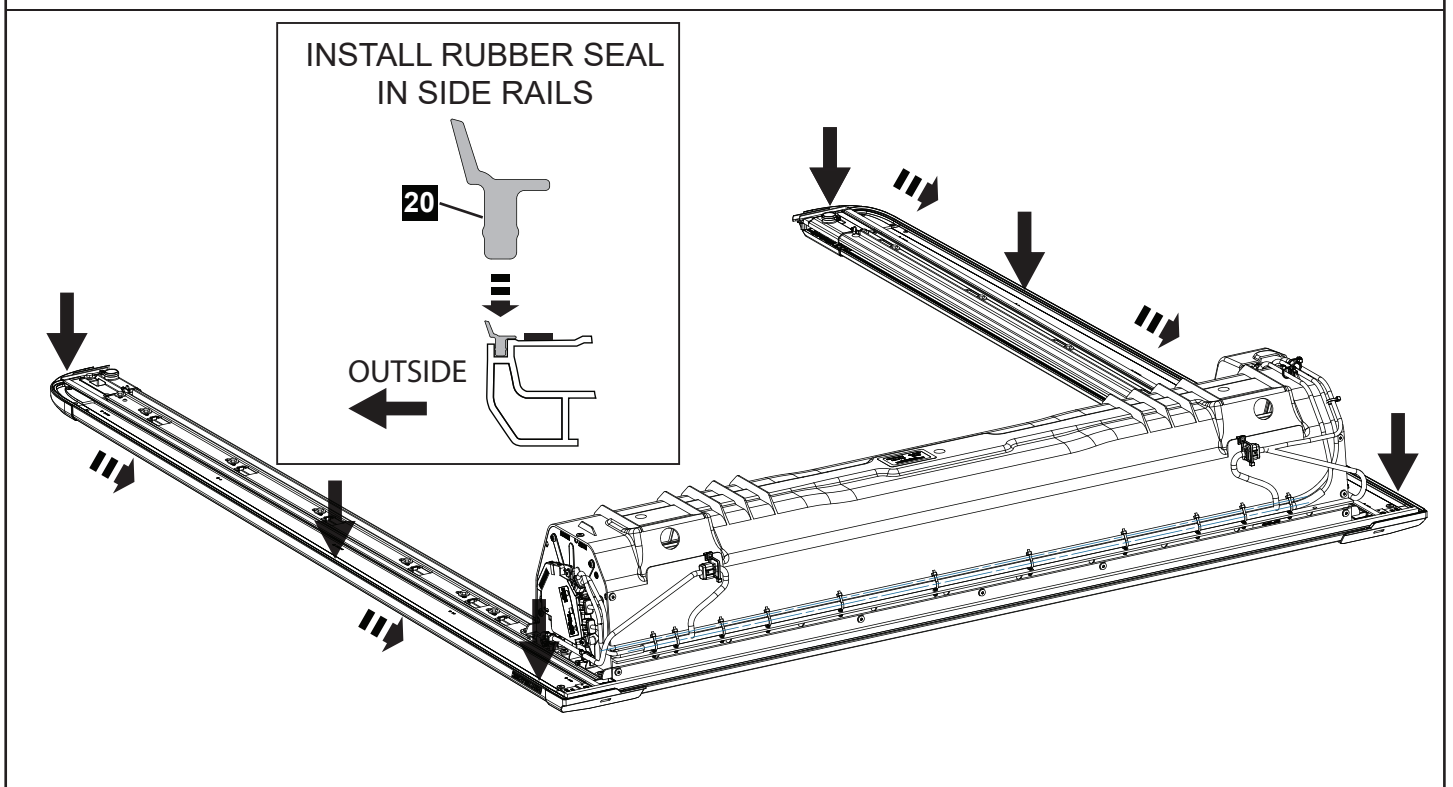

- 10** Install the Rubber Perimeter Seal (20) into each side rail and ensure seal is firmly seated (note the seal orientation). **Important:** do not stretch the seal while fitting.

## SETTING BRACE - USER GUIDE



- NOT TO BE USED AS LIFTING DEVICE
- MEASUREMENTS ARE STILL REQUIRED AS PER THE FITTING INSTRUCTIONS
- SETTING BRACE SHOULD BE REMOVED ONLY WHEN SET UP IS COMPLETED

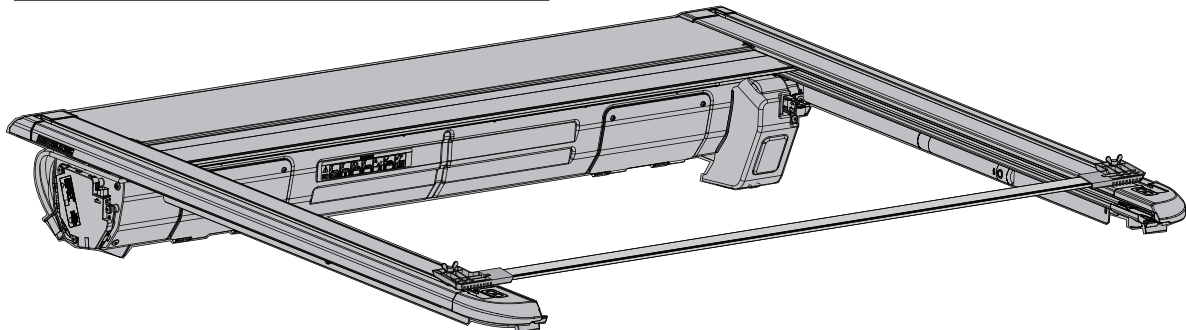
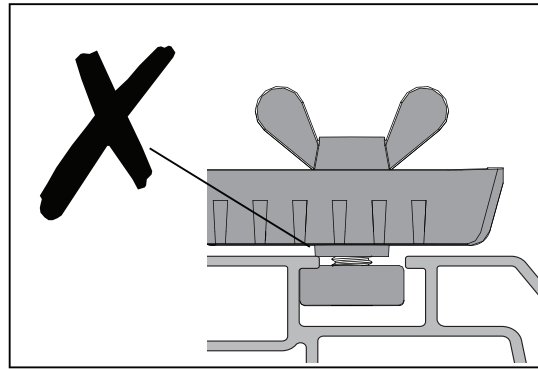
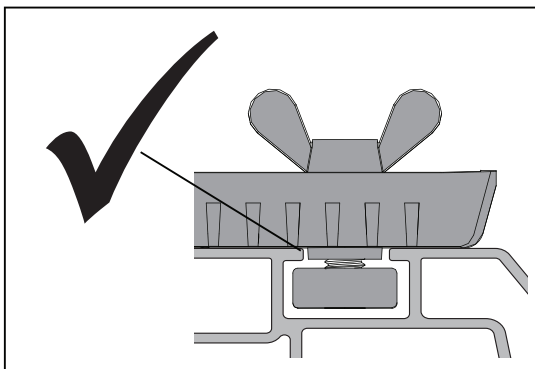
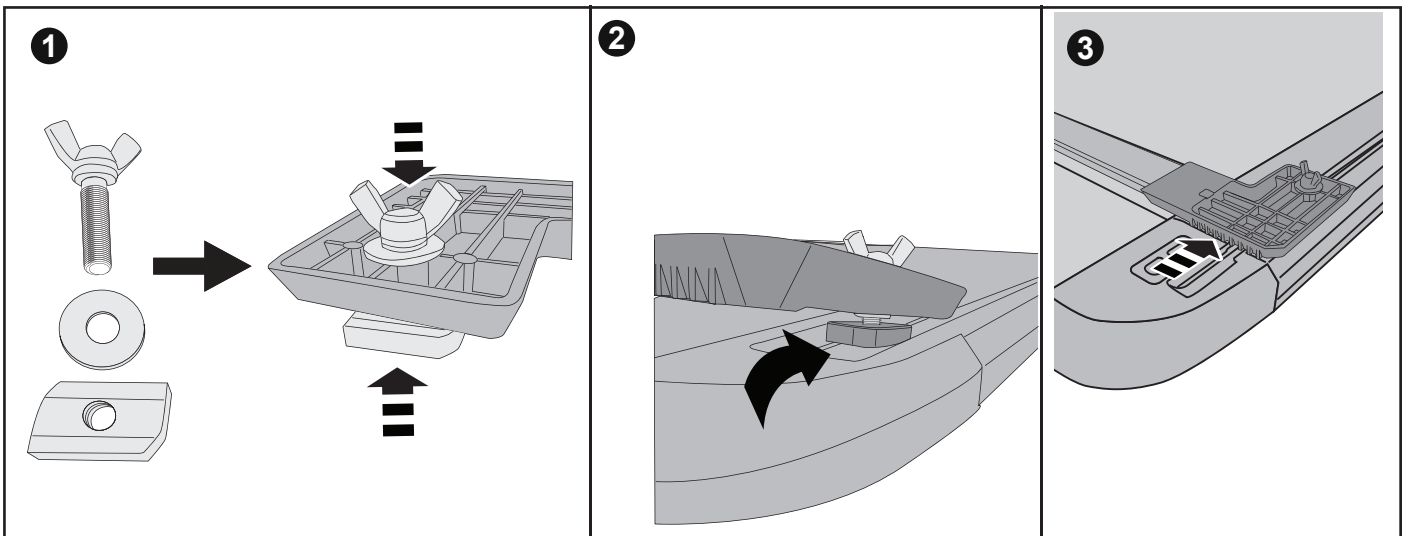
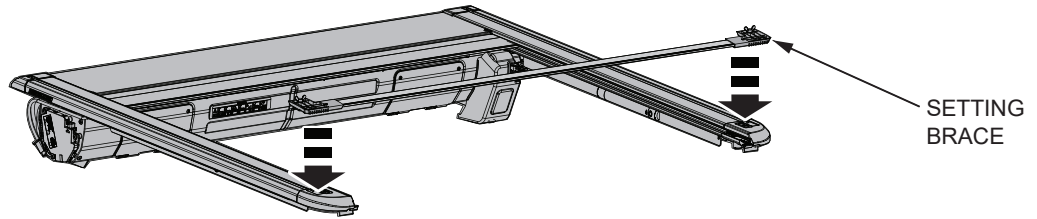

1

Setting Brace comes pre-assembled. Fit the T-Nuts with washers and wing screws as shown to both ends of the Setting Brace. Place the Setting Brace over the rear of the Rolltrac and slide the T-Nuts into the slots as shown. Once in position, slide the brace backwards till the plastic part of the brace comes to contact with the edge of the rear End Cap.

**NOTE:** Brace is equipped with locators at the bottom and those must be fitted into the side rails. Tighten the wing bolt (finger tight only).

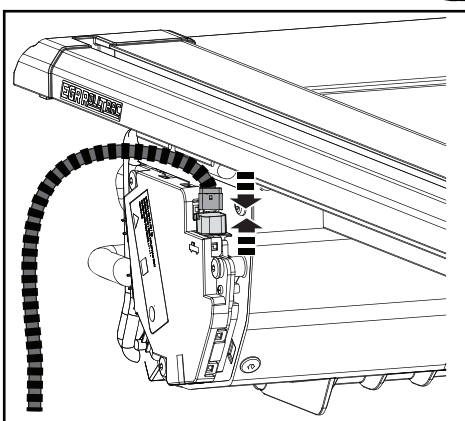
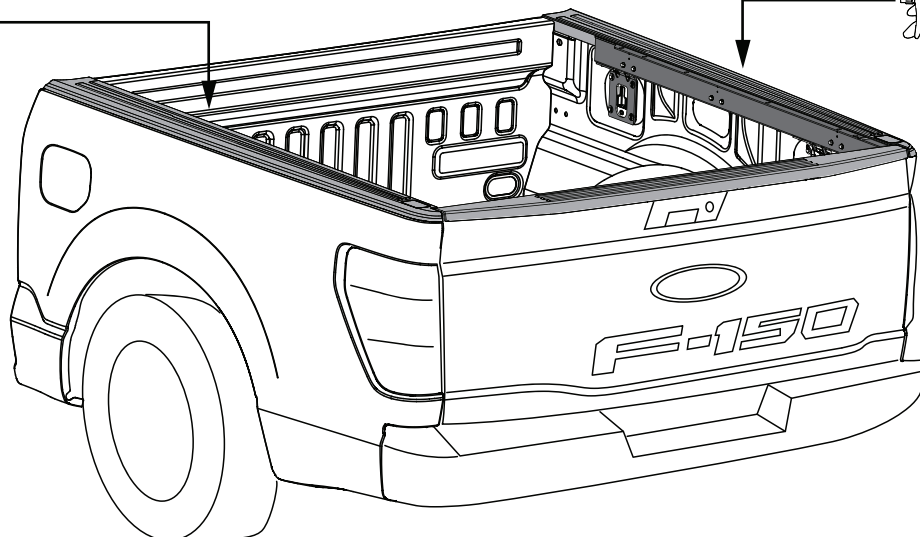
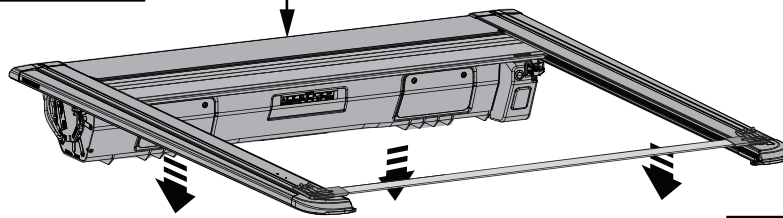
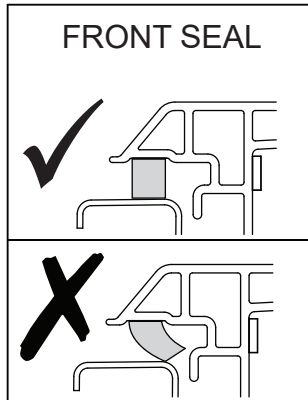

CONNECT



1 PUSH

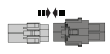

2 CLICK



3 PULL



PULL THE CONNECTORS  
NOT THE CABLE

- 1 Spray the top surface of the bed liberally with a soapy water solution to enable the Cover to slide easily. Using two people to lift the cover from both sides and carefully lower it onto the bed. Connect the vehicle harness to the ECU as shown. **NOTE:** You may have to lift the LHS of the cover and use packer to aid connection. Ensure all seals are sitting vertically as illustrated.

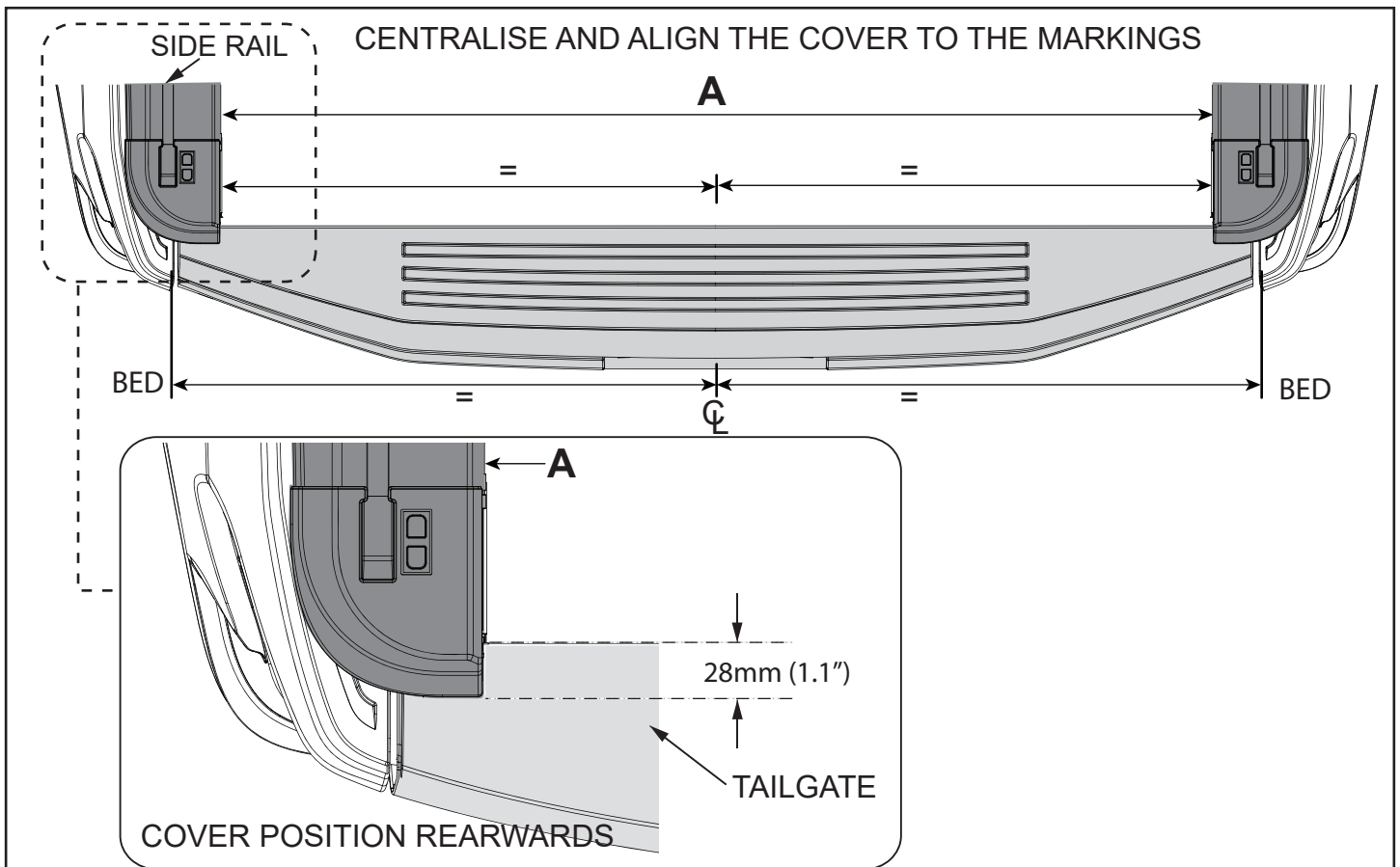

- 2** Apply masking tape at the center of the tailgate and each end to mark length. Measure the distance between the rear corners of the bed and draw a center line on the masking tape. Measure the distance from the marked center line to both rear corners of the RollTrac and ensure it is equally distanced. Adjust the cover so that it is aligned with the markings as shown. Ensure seals are not deformed by lifting cover and dropping vertically on bed.

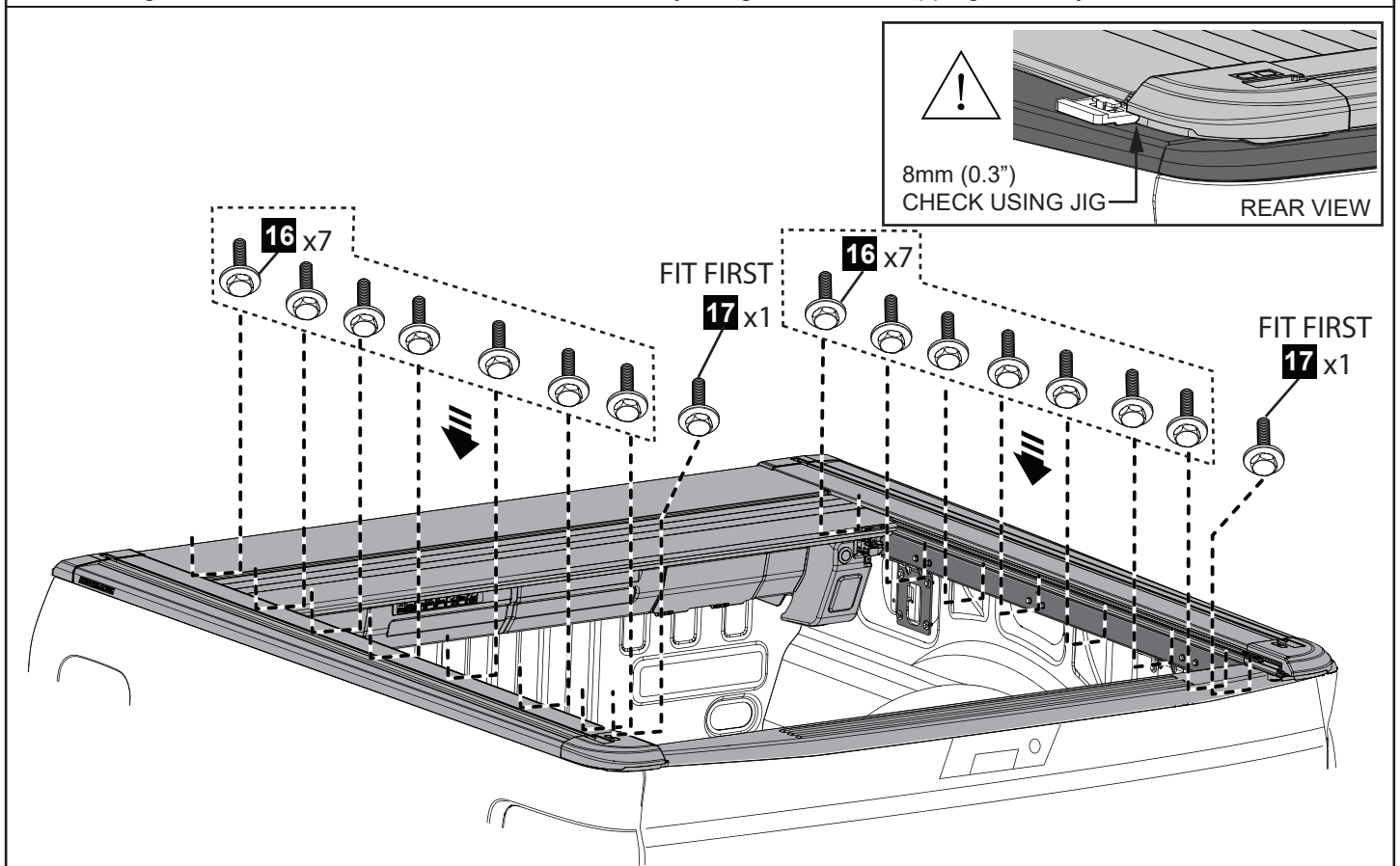

- 3** Secure the rear of the Rolltrac side rail to the mount extrusion with one screws (17) on each side as shown. Secure the side rail with 7 screws (16) on each side. Work from RHS to LHS to avoid one side lifting up.  
**NOTE:** M6 metal plates inside the side rail can be moved to line up with holes, before fitting screws.  
 Do not tighten yet. **IMPORTANT:** Check the clearance between rear corner casting and top of tailgate, target is 8mm.

# PERFORM FITMENT CHECK



A = A    B = B

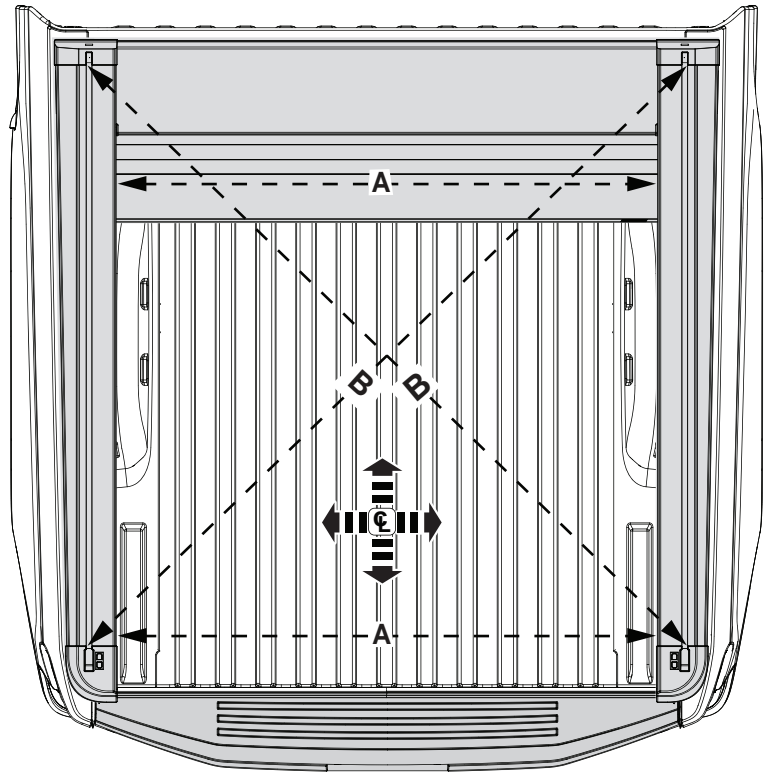

**4** Perform width check (using canister end as reference) and diagonal fitment check (mounting bolts may need loosening for adjustment). Open and close the cover by hand, checking for smooth operation and consistent 1.5-2.0mm(0.05-0.07") side to side free-play of slat assembly within side rails. If there are any tight spots, then check side rail position and re-adjust side rail width as required.

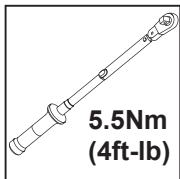

**1** 5.5 Nm  
4ft-lb

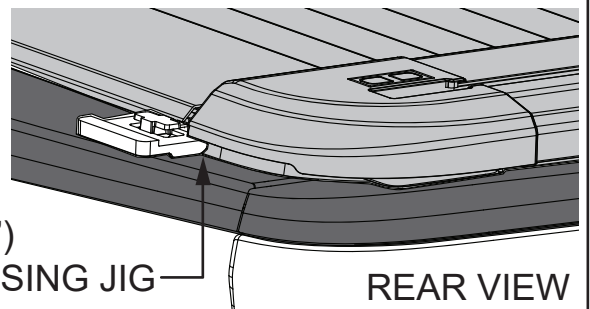

8mm (0.3")  
CHECK USING JIG

REAR VIEW

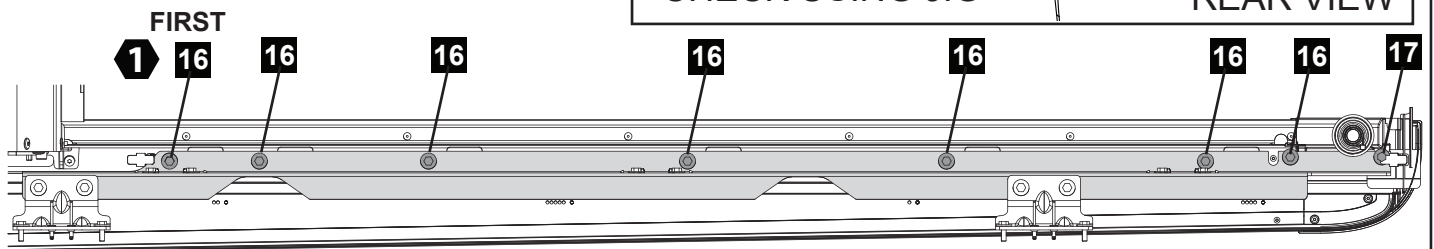

VIEW UNDER THE SIDE RAIL RHS (BED NOT SHOWN FOR CLARITY)

**5** Working from RHS to LHS (to avoid one side lifting up) torque all screws to 5.5Nm (4ft-lb). Perform final fitment check as per step 4. **IMPORTANT:** Check the clearance between rear corner casting and top of tailgate, target is 8mm. Open and close the tailgate to check function of seal (makes contact with tailgate and does not over compress) if position requires adjustment refer to steps 12-14 (section A).

## CONNECT FRONT DRAIN TUBES TO CANISTER

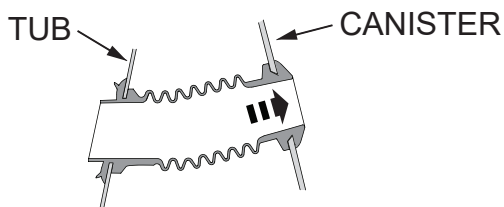

## FIT REAR DRAIN TUBES TO SIDE RAILS

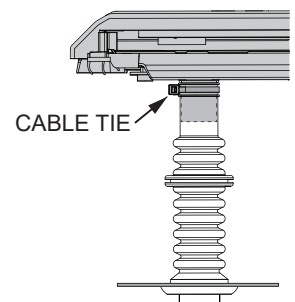

**6** Connect the front drain tubes to the canister. Connect the rear drain tubes to side rails and secure with cable ties.

## SILICONE LUBRICATION TO THE SPIRALS (MODELS MAY VARY, IMAGES FOR REFERENCE ONLY)

- 1** Open tailgate and EGR RollTrac

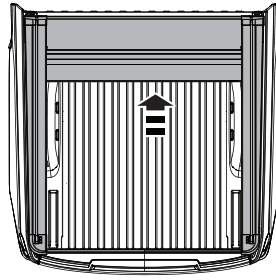
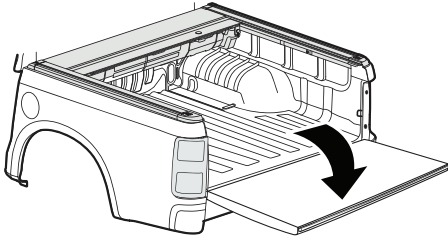

### TOOLS REQUIRED:

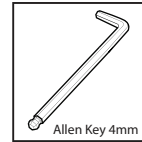

Allen Key 4mm



Silicone Spray



Face mask

- 2** Using a 2.5mm Allen Key remove the 4 screws and open the inspection covers.  
**WARNING:** Keep clear of moving parts and avoid unnecessary operation of the EGR RollTrac while inspection covers are open.

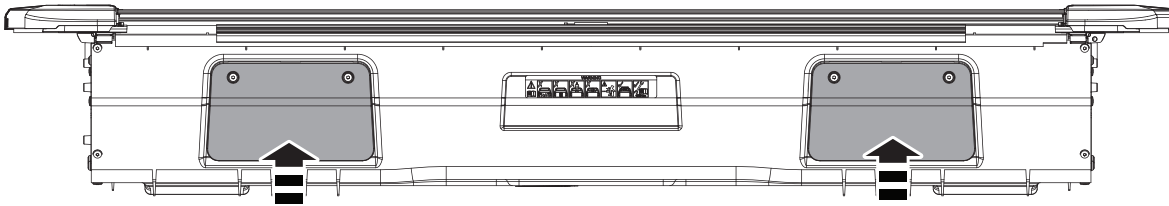

INSPECTION COVER

INSPECTION COVER

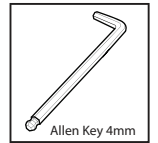

Allen Key 4mm

- 3** Close the EGR RollTrac to access canister internals

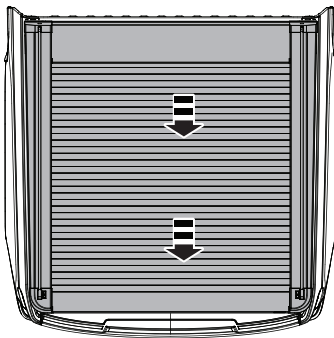

- 4** To avoid water leaks, look into the inspection points and check that the flanges of both front drain tubes are correctly engaged to the canister cover (without any kinking etc.), readjust if required.

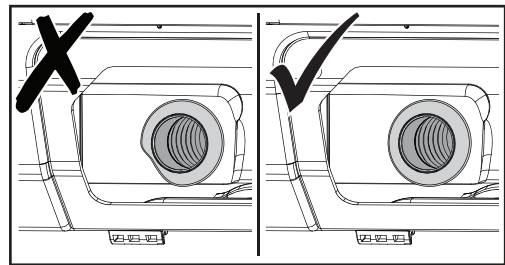

- 5** Using plastic compatible 100% Silicone Spray (ONLY) spray onto the spirals on both ends of the canister through the inspection points.

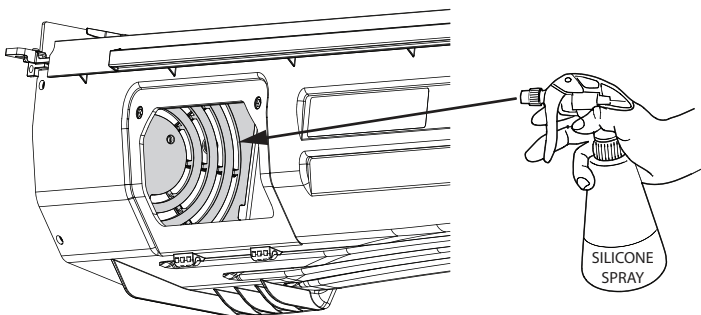

- 6** Open the EGR RollTrac

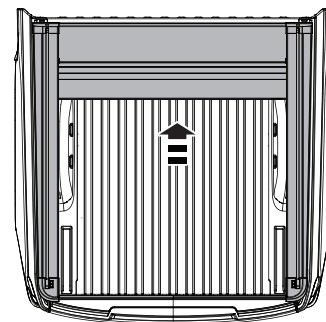

- 7** Close the inspection covers and secure with retained screws. Open and close the EGR RollTrac to distribute lubricant and check operation.

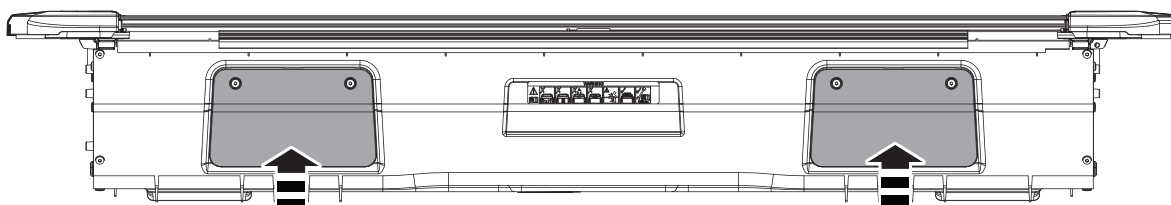

INSPECTION COVER

INSPECTION COVER



Allen Key 4mm

1. Insert fuse to EGR RollTrac harness.
2. Make sure the tailgate is closed.
3. Engage motor, pull out lever (clutch).
4. Make sure the vehicle is unlocked and driver door open.
5. Press both buttons and hold for 5 sec. until light illuminates.



**WARNING:** Keep obstructions clear of cover during calibration mode.

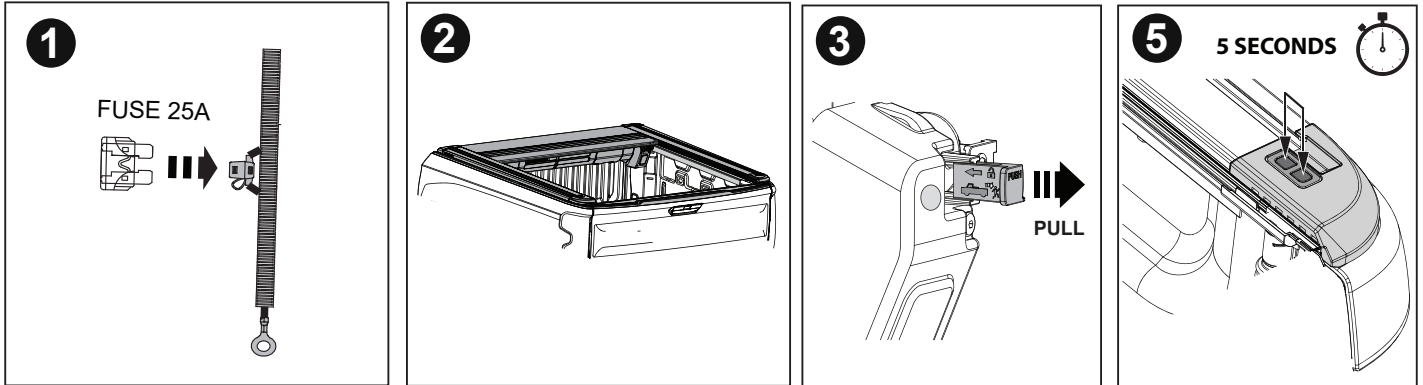

- Cover will CLOSE and OPEN once automatically.
- The EGR RollTrac internal LED light will pulse slowly during calibration and stop pulsing when calibration is complete.



START OF CALIBRATION

2 SECOND PULSE  
DURING CALIBRATION

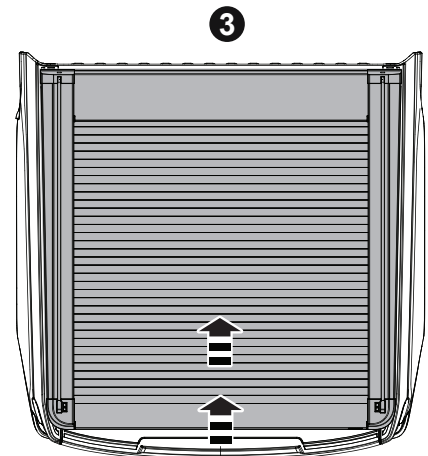
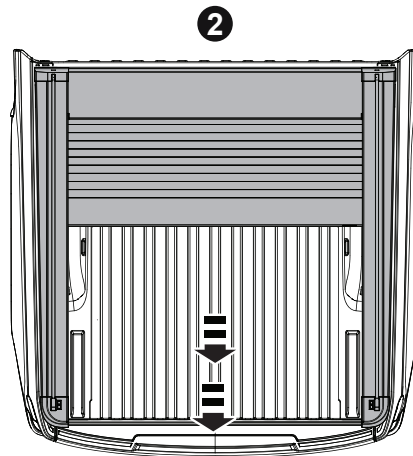
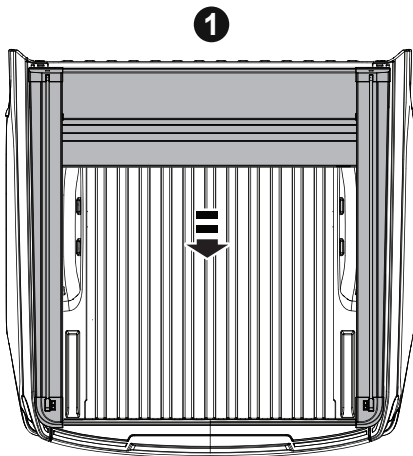

END OF CALIBRATION

## OPENING AND CLOSING PROCEDURE

### Electric Opening Procedure:

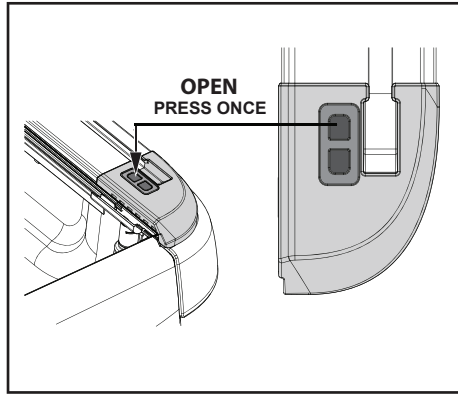
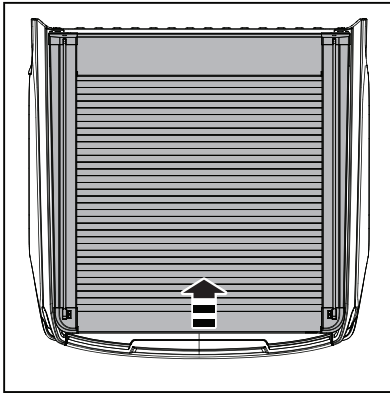

1. Press the front button on the EGR RollTrac side rail as shown.

### Electric Closing Procedure:

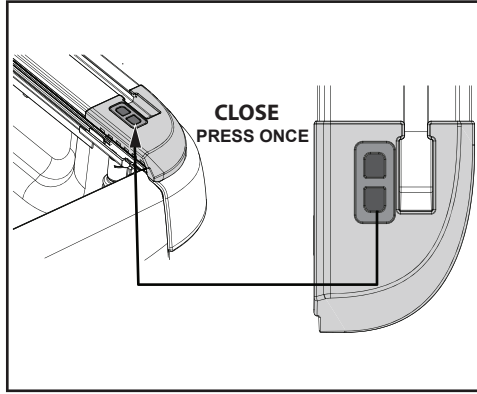
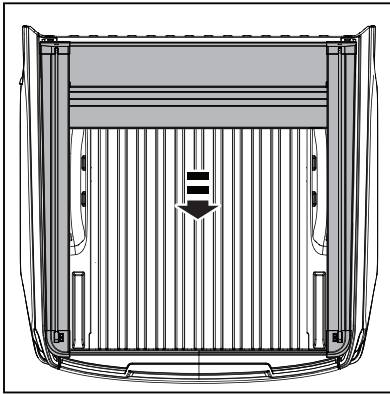

1. Press the rear button on the EGR RollTrac side rail as shown.

NOTE: EGR RollTrac should open and close smoothly. If cover does not lock or open correctly, please refer to the trouble shooting section in the Owners Manual. If the EGR RollTrac closing is slow, clean the siderails and ensure that no dirt or debris is inside the drive rail.

### Manual Opening and Closing Procedure:

Locate the Clutch Disengagement Lever on the RH side of the cover and push the Clutch inward to disengage the motor. Pull the cover rearward or forward as required. Before driving vehicle ensure you re-engage the clutch.

**IMPORTANT:** If clutch was disengaged, calibration procedure needs to be re-run prior to electric operation.

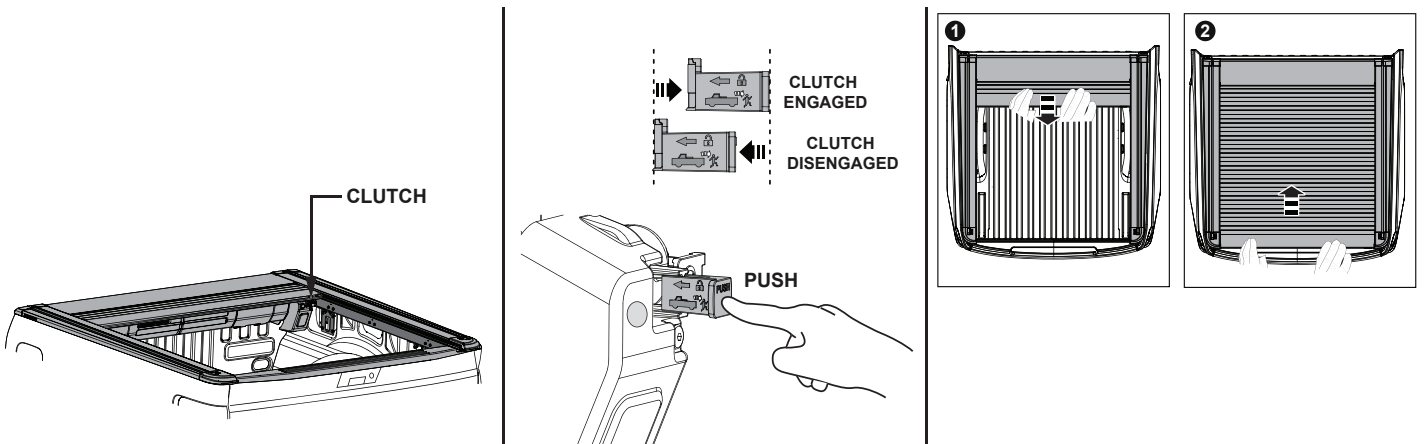

## UTILITY HOOKS REFIT (OPTIONAL)

### RHS MOUNT EXTRUSION ASSEMBLY

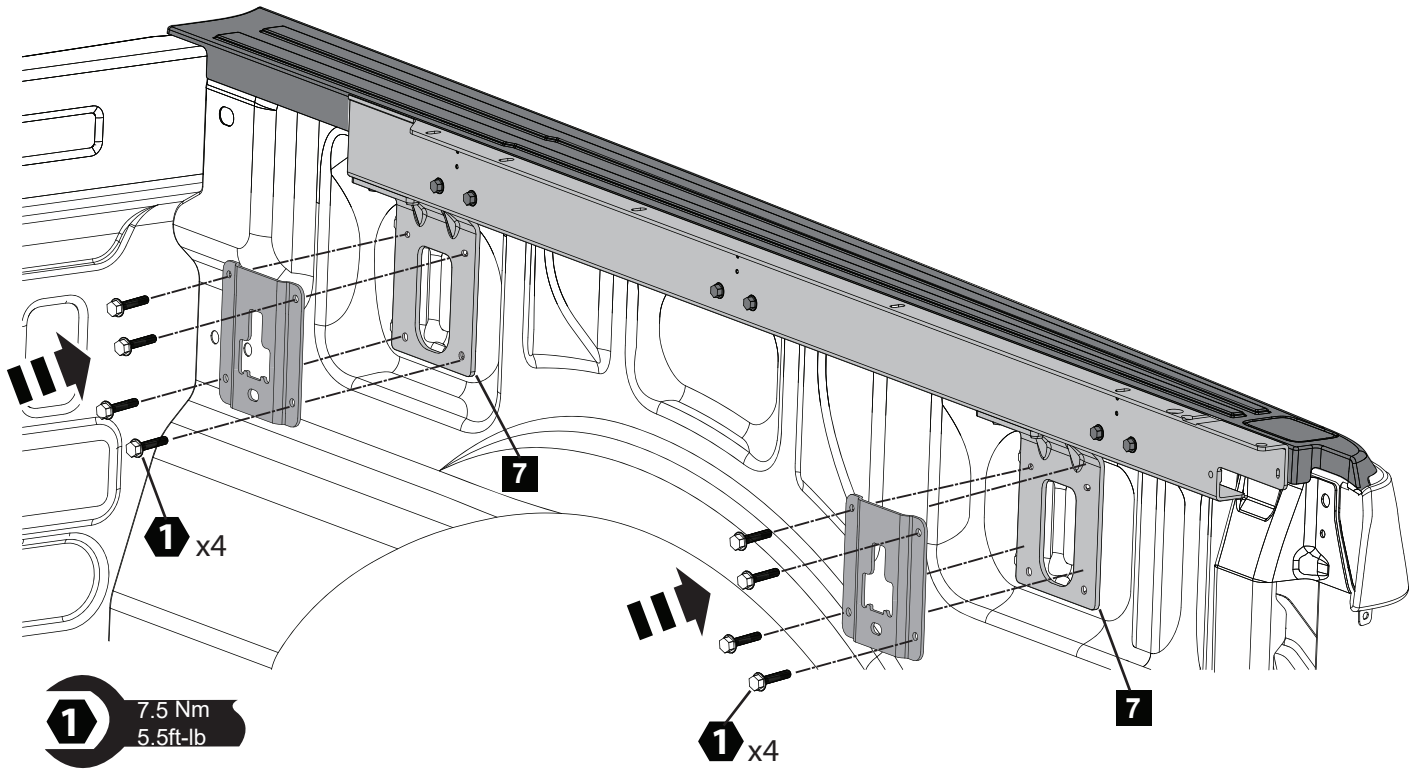
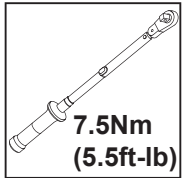

OPTIONAL: Remove the screws holding the side brackets (7). Fit the utility hook brackets (if provided - removed in step 1) and fit over the support brackets using same screws. Torque to 7.5Nm (5.5lb-ft).

# KEY FOB OPERATION

IMPORTANT: We recommend that you program your key fob to lock and unlock all doors using one click only. This function can be set on your infotainment screen using the vehicle system control function/setup:

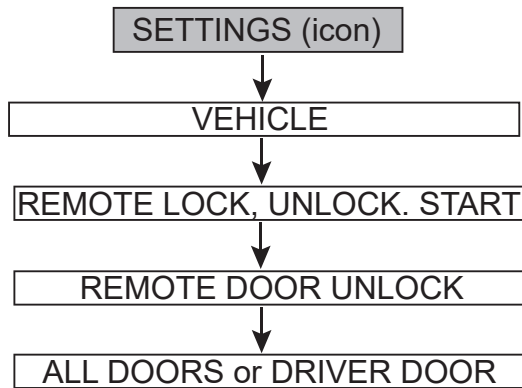

## LOCKING / AUTO CLOSE PROCEDURE

### Key Fob

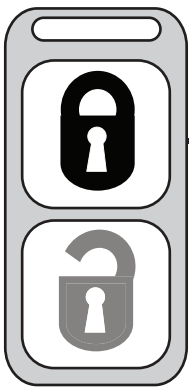

1. Press lock twice within 2 second, the vehicle will lock, if closed the RollTrac will lock, if open it will auto close.
2. To pause while in auto close motion, press lock once and the RollTrac will stop.
3. To resume auto close, press lock twice within 2 second.
4. When auto close is complete the RollTrac will auto lock.

## UNLOCKING / AUTO OPEN PROCEDURE

### Key Fob

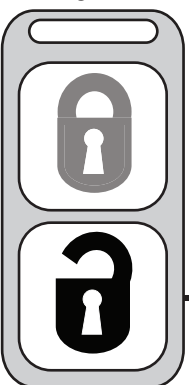

1. Press unlock 4 times within 2 second, the vehicle will unlock and the RollTrac will auto open.
2. To pause while in auto open motion, press unlock button once and the RollTrac will stop.
3. To resume auto open, press unlock twice within 2 second.
4. When auto open is complete the RollTrac will remain open until operated by either the key fob or the RollTrac buttons.

## NOTES

- If pause is activated by the fob whilst auto closing, the RollTrac can be closed and paused using the RollTrac close button. Reactivate both Rolltrac buttons by unlocking the vehicle.
- If the RollTrac is open and the lock button is only pressed once, the vehicle and the RollTrac will lock.