



AEROMOTIVE
Part # 18075/18076
2016-2020 Camaro/2016-2019 CTS-V/ATS-V
Pump Module
INSTALLATION INSTRUCTIONS

This product is not legal for sale or use on emission-controlled vehicles except when used as a direct replacement part matching OEM specification.

WARNING!



Always be aware of flammable situations. Drilling and grinding can be potential ignition sources. Extinguish all open flames, prohibit smoking and eliminate all sources of ignition in the area of the vehicle and workspace before proceeding with the installation. Ensure you are working in a well-ventilated area with an approved fire extinguisher nearby.

WARNING!



Installation of this product requires modification to a fuel tank/ the fuel system, failure to satisfy all safety considerations will result in fire, explosion, injury and/or loss of life to yourself and/or others. All fuel system components **MUST** be located as far from heat sources as possible, like exhaust, engine block, etc.

WARNING!



Mechanical and hydraulic lifting devices can tip over or lower accidentally due to incorrect maneuvering or technical errors. A falling object can cause injury and/or loss of life to yourself and/or others. When working under the vehicle, always use stands, and ensure that the ground or floor is stable and level. Never crawl under a vehicle which is only supported by a jack.

WARNING!



The fuel system is under pressure. Do not open the fuel system until the pressure has been relieved. Refer to the appropriate vehicle service manual for the procedure and precautions for relieving the fuel system pressure.

CAUTION!



When installing this product always wear safety glasses and other appropriate safety apparel. A drilling operation will cause flying metal chips. Flying metal chips can cause eye injury.

CAUTION:



Installation of this product requires detailed knowledge of automotive systems and repair procedures. We recommend that this installation be carried out by a qualified automotive technician. Careless installation of this product can result in damage to the product, injury or loss of life to yourself and/or others.

Compatible Fuels:

Pump Gas
Race Gas
E85

Aeromotive system components are not legal for sale or use on emission-controlled motor vehicles.

This pump assembly is a high-performance factory replacement unit. Key features:

- **Drops directly into the factory fuel tank (NO CUTTING REQUIRED).**
- **Utilizes OEM jet siphon in conjunction with factory jet siphon system plumbing.**
- **High flow pre-filter built into inlet of pump.**
- **Includes fuel level mounting bracket for factory fuel level sending unit.**

NOTE: The use of Teflon braided line with machine crimped hose ends is recommended. This eliminates the possibility of fuel vapors permeating through the fuel line.

Maximum continuous operating pressure should not exceed 65 psi.

The enclosed Aeromotive fuel pump utilizes AN-10 ORB (O-ring Boss Port) style for the outlet and -08 ORB for the return and vent ports; these ports are **NOT PIPE THREAD** and utilize **NO THREAD SEALANT**.

Pump Specifications:

	18075 Kit (Pump 2x #11145)	18076 Kit (Pump 3x #11145)
Outlet pressure/typical flow:	40 psi / 2x 381 LPH @ 13.5 V 60 psi / 2x 324 LPH @ 13.5 V	40 psi / 3x 381 LPH @ 13.5 V 60 psi / 3x 324 LPH @ 13.5 V
Continuous Operating Range:	30 psi – 65 psi @ 13.5 V	30 psi – 65 psi @ 13.5 V
Pump internal By-Pass Pressure:	120 psi	120 psi
Current Draw:	2x 15.3 amps @ 40 psi	3x 15.3 amps @ 40 psi

Aeromotive Related Components:

Fuel Filters:

12341 10 micron microglass ORB-12
12350 10 micron microglass ORB-10
12305 filter bracket

Check Valves:

15107 (10AN)

Fuel Pressure Regulators:

13305 (-8 ORB ports)

Fuel Pressure Gauge:

15633 (dry 0-100psi)

Outlet Cap Port Fittings:

15607 (-8 ORB x -8 AN Male)
15608 (-10 ORB x -10 AN Male)
15610 (-10 ORB x -08 AN Male)
15136 (-8 ORB x 5/8 Quick Connect) – **Included**

Electrical Components:

16307 (30A pump wiring kit)
16308 (60A pump wiring kit)

Direct Injection High Pressure Pump Inlet Tee Fitting:

15137 (2x -08 ORB Port x 3/8 Quick Connect)

NOTE: This pump module installation requires an experienced tuner/installer that is familiar with integrating the OEM direct injection system with a supplemental fuel system. This system is intended to fuel both the OEM direct injection system in conjunction with a supplemental fuel system. Integrating the direct injection wiring and plumbing with the supplemental wiring and plumbing should only be done by an experienced tuner/installer. Upgraded wiring is required to power the fuel pumps installed on this pump module. 10 gauge wire is recommended for powering an individual pump and 8 gauge wire is recommended for powering two pumps simultaneously. Part number 18076 (Triple 450 Pumps) requires 8 gauge wire to power the "Aux" terminals.

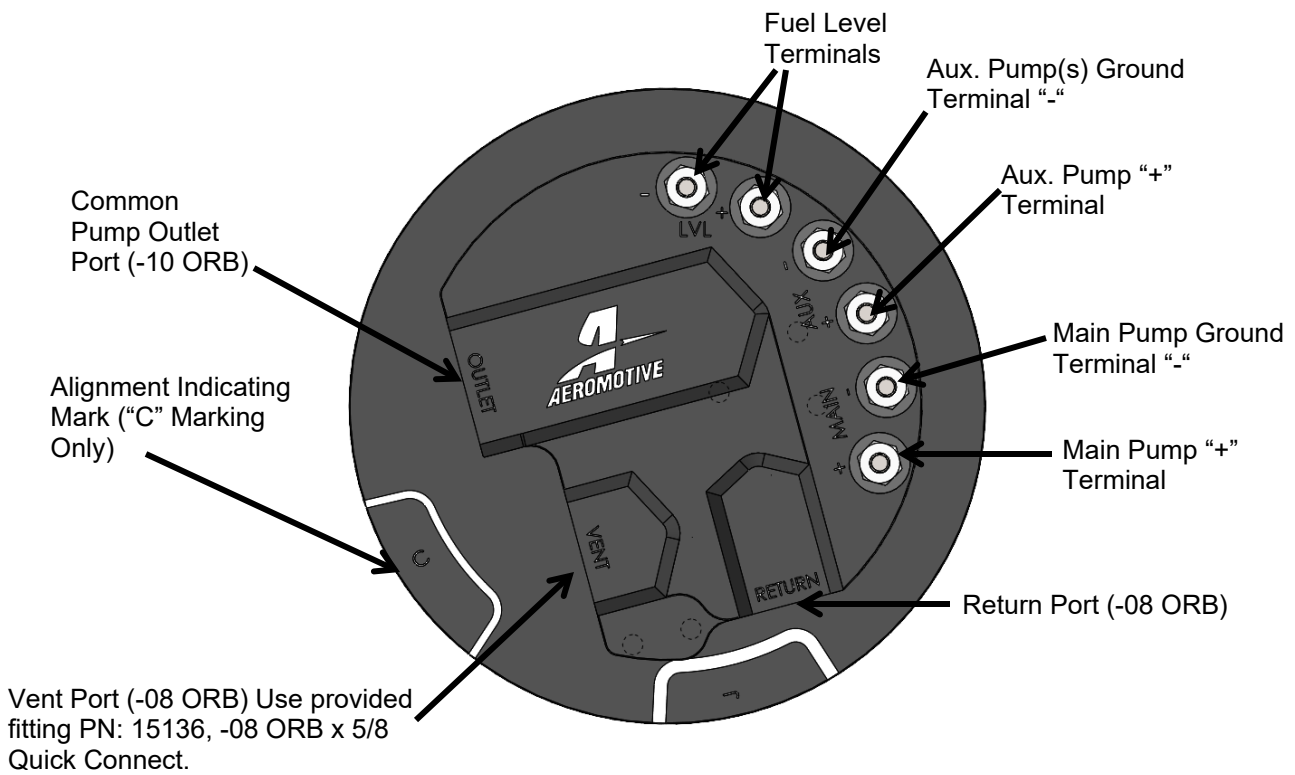

OUTLET CAP LAYOUT

The following steps are typical of most installations:

1. Drain the fuel tank, relieve system pressure (refer to service manual for proper procedure), and disconnect the battery.
2. Remove the fuel tank from the vehicle following the manufacturer's suggested procedure (refer to service manual for proper procedure).
3. Remove the fuel line and vent tube by pressing the tabs on the quick connect fittings and unplug the wire connectors. Be sure to not damage the vent tube as this will be reconnected to the new outlet cap. Wipe the top of the fuel pump module clean to limit the amount of dirt and debris that can fall into the tank.

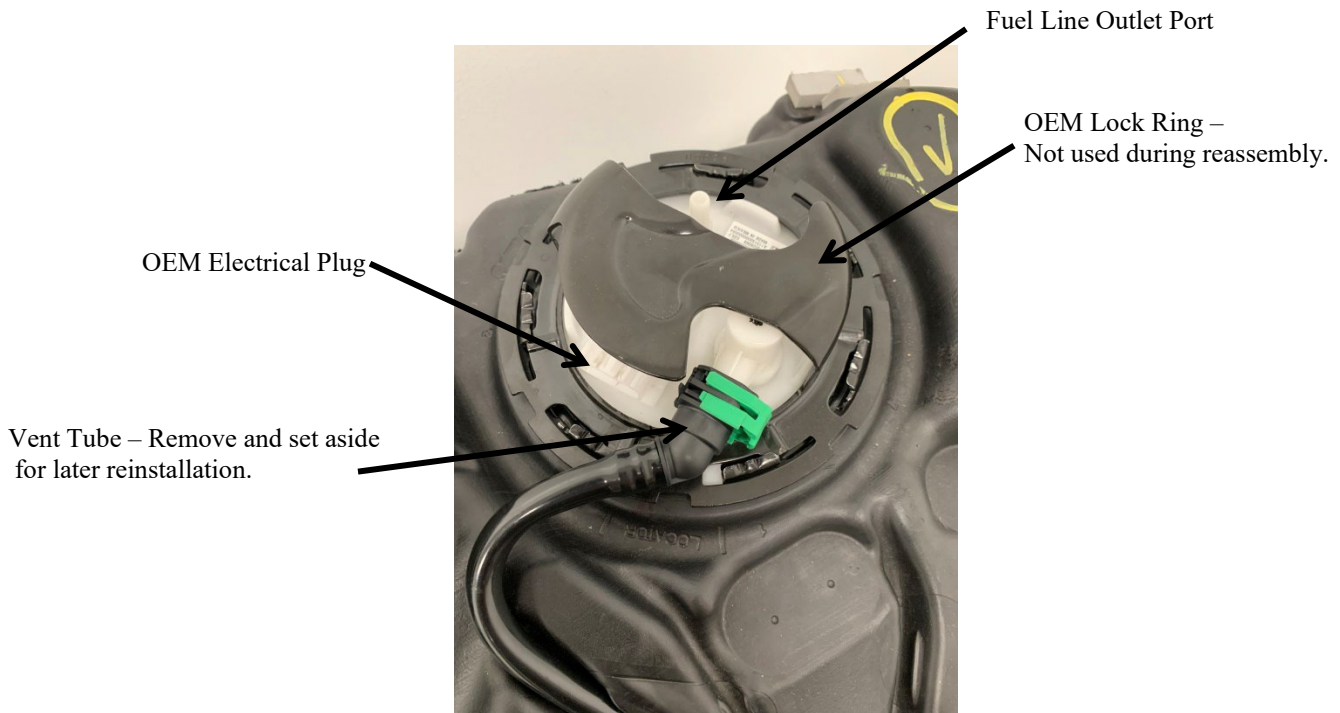

4. Remove the lock ring from the top of tank, (only remove the lock ring from the pump side, the siphon side lock ring will not be removed). Remove the pump module from the tank by carefully lifting up on the module and then disconnecting first the internal vent tube, then the siphon return, and finally the siphon pressure tube. **Note: All internal tank quick connect hoses are reused, do not cut or destroy fittings during disassembly.** Be careful not to spill fuel or damage the fuel level sending unit as shown in the image following.

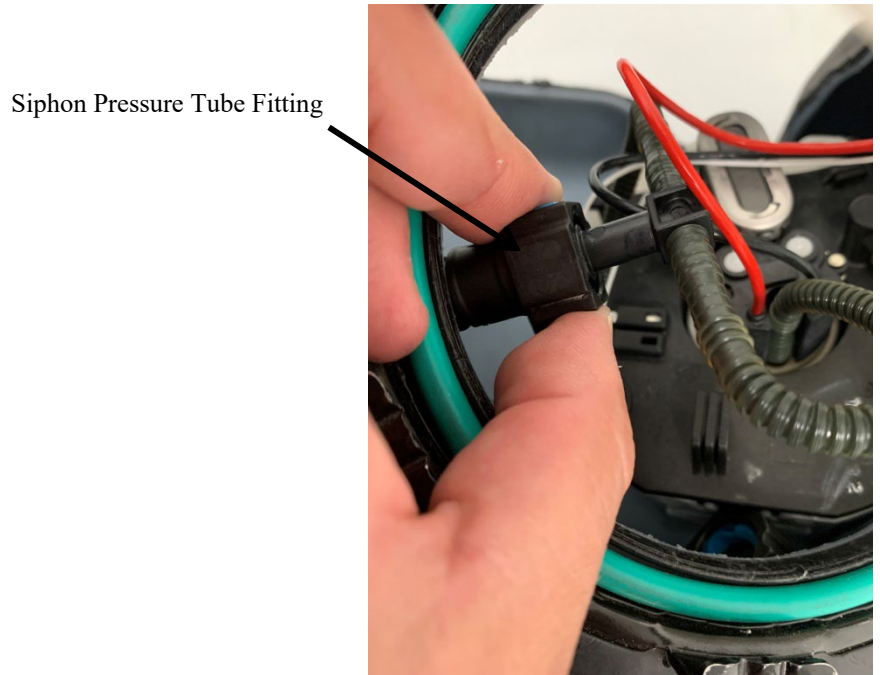
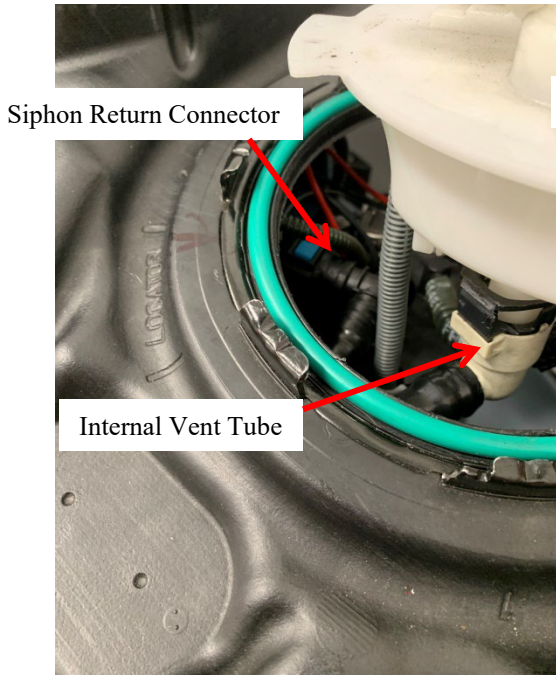

CAUTION: Immediately wipe up any fuel spills from the hoses.

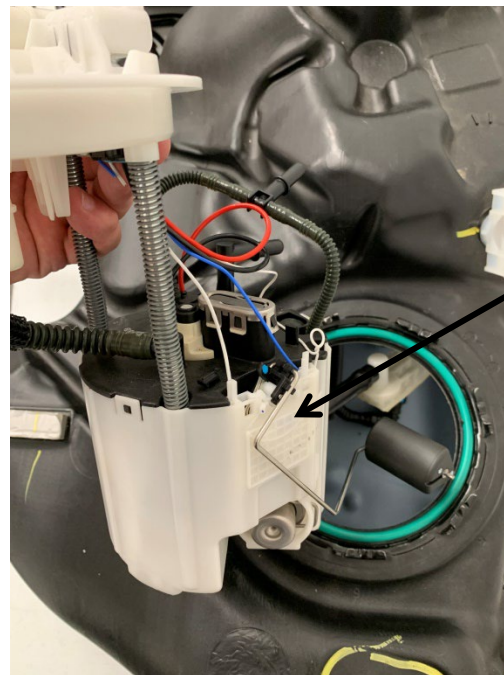

5. Once the OEM fuel pump module is fully removed from the tank, carefully remove the fuel level sender from the OEM fuel bucket. To do this, depress the two small tabs shown in the following image; slide the fuel level sender up to remove from the fuel bucket. Unplug the fuel level sender wires from the bottom of the OEM fuel outlet cap.

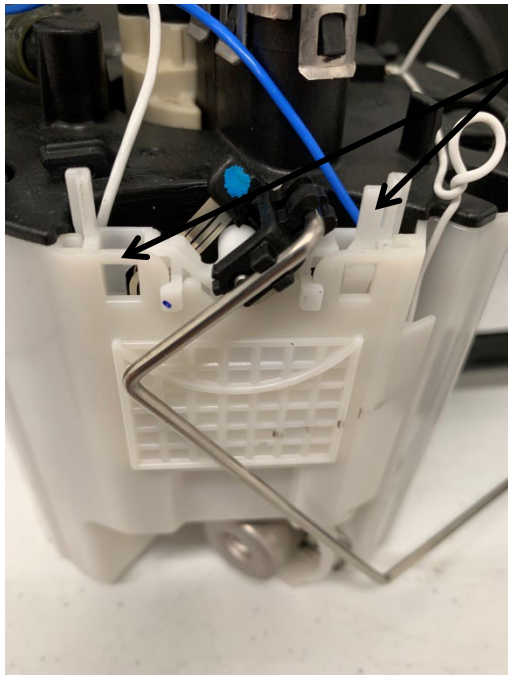

Depress two plastic tabs to remove fuel level sender.

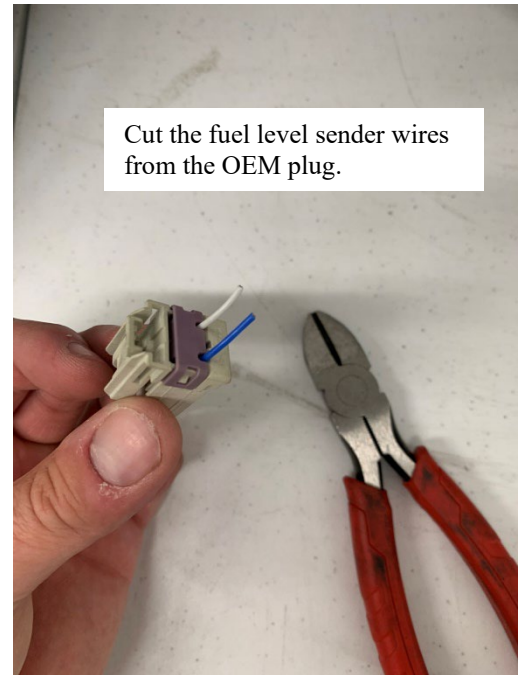

6. Cut the wires from the fuel level sender near the plug as shown in the above image, leave as much wire length as possible on the fuel level sender.
7. Strip the ends of the wires from the fuel level sender. Crimp on the new male blade connectors as shown in the following image.

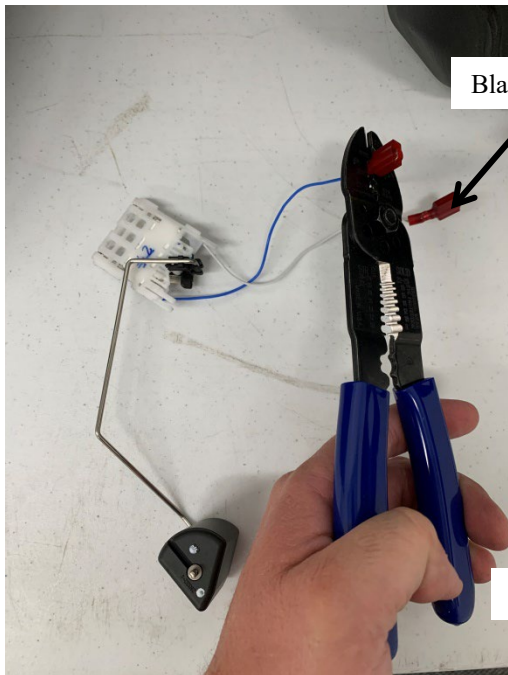

Blade Connectors

Fuel Level Sender Mounting Bracket

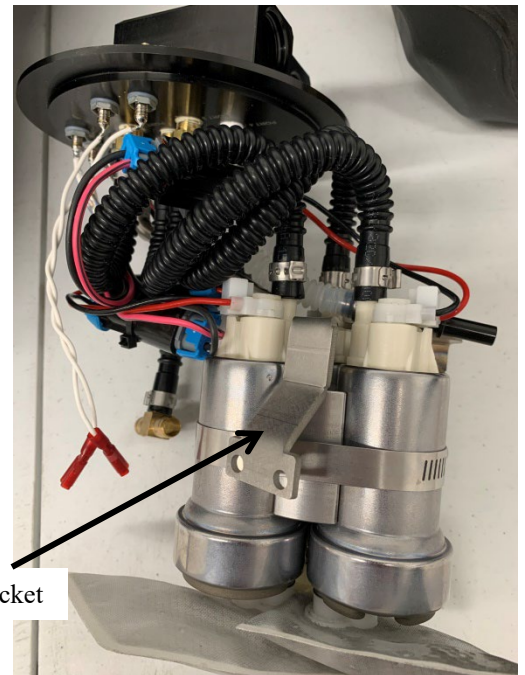

8. Attach the OEM fuel level sender to the Fuel Level Sender Mounting Bracket as shown in the above image. To do this, use the two 10-24 button head screws and nyloc nuts to attach the level sender to the bracket. The screws should be inserted through the bottom two square holes of the plastic as shown the below image. **Note: If the screws are installed in the top two holes the level sender will read incorrectly.**



Connect male and female blade connectors to LVL wires from Outlet Cap.

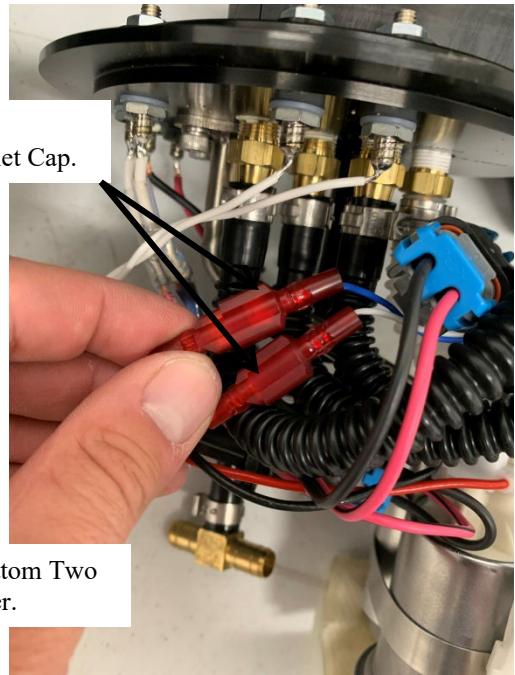

Insert Screws Through the Bottom Two Holes in the Fuel Level Sender.

9. Connect the two male and female blade connectors with the white wires from the “LVL” terminals on the bottom of the outlet cap. **Note: Route the wires from the fuel level sender to ensure they are secure and do not interfere with the movement of the fuel level sender arm. Securing the wires with a small nylon cable tie may help keep the wires from interfering with the fuel level sender arm movement.**

10. Install each fuel pump strainer (pre-filter) on each fuel pump.

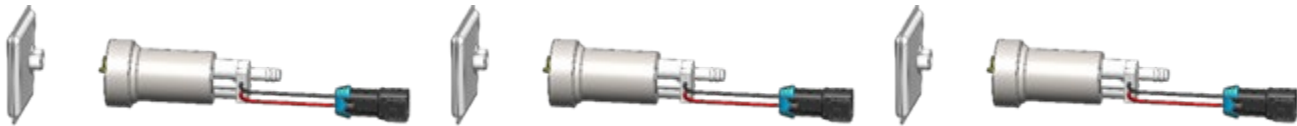

11. Loosely insert the pump assembly into the fuel tank; there are three hoses inside the tank that will connect to the new fuel pump outlet cap. Be careful not to damage the fuel level sender when inserting the pump into the tank. **Note: It is helpful to have a small wire with a hook on one end to help retrieve the hoses inside the tank.**

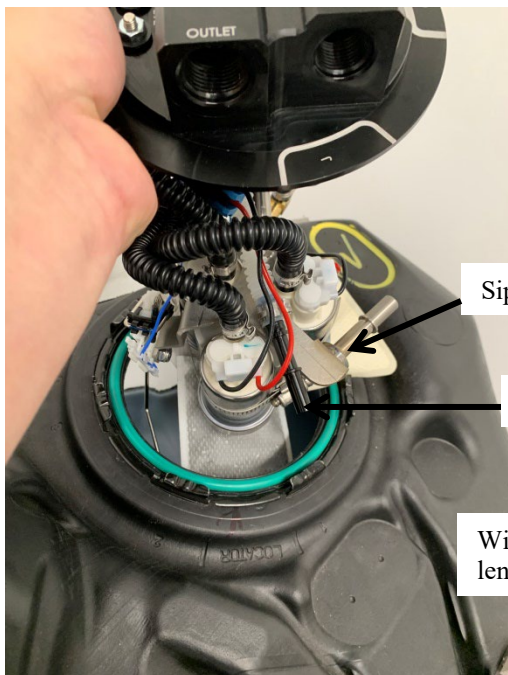

Siphon Return Flow Fitting

Siphon Pressure Fitting

Wire with hook end - (approximately 12” length).

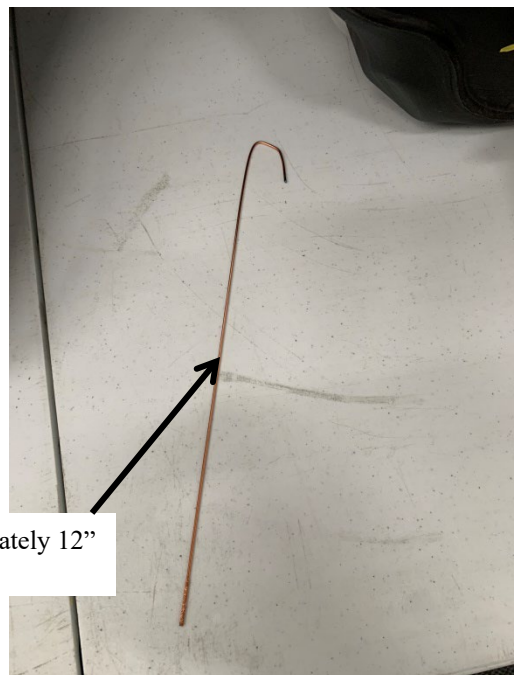

12. The three hoses inside the tank are shown in the image below; all three hoses are used during the fuel pump module installation.

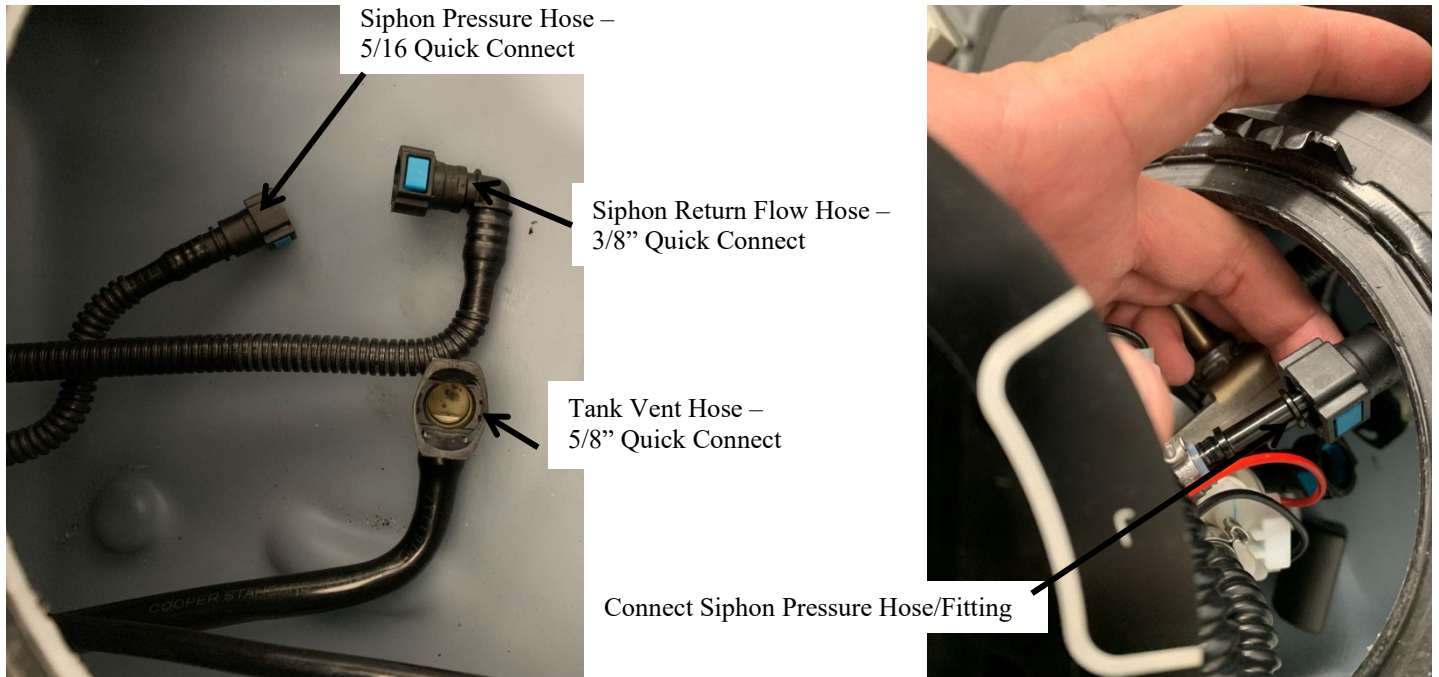

13. Once the pump assembly is loosely inserted inside the tank, first connect the Siphon Pressure Hose to the Siphon Pressure Fitting shown in the image above. Ensure the connector is fully engaged and is secured on the fitting; the fitting should “click” when fully engaged.

14. Next, connect the Siphon Return Hose to the stainless steel male 3/8” quick connect fitting that is attached to the pump assembly. The wire hook is useful to help retrieve this hose and get it into position. Ensure the connector is fully engaged and is secured on the fitting; the fitting should “click” when fully engaged. The connection of the Siphon Return Hose is shown in the image below.

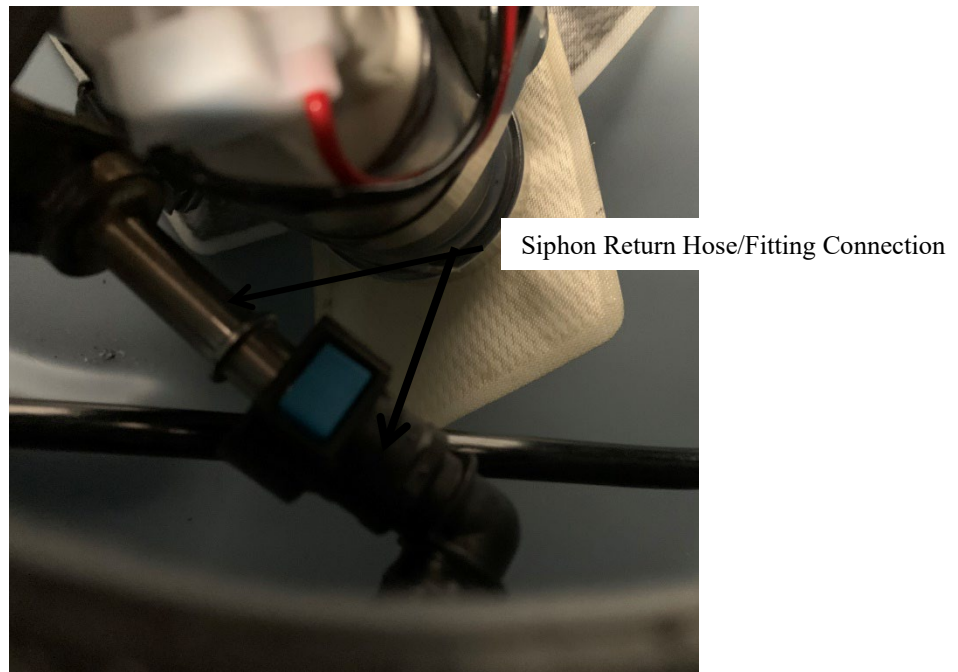

15. Connect the internal tank Vent Hose to the 5/8" quick connect fitting on the bottom of the outlet cap. The wire hook is useful to help retrieve this hose and get it into position. Ensure the connector is fully engaged and is secured on the fitting; the fitting should "click" when fully engaged. The connection of the internal tank Vent Hose is shown in the image below.

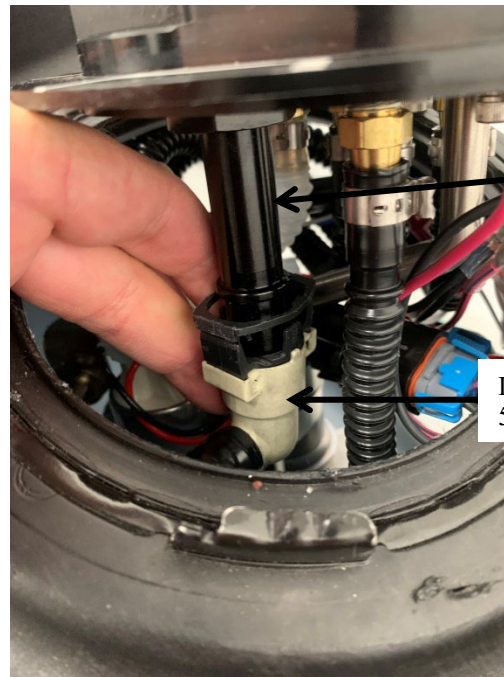

16. Once all internal tank hose connections are made, install a new tank gasket (not included) around the outlet cap and position in the tank seal groove. Ensure the gasket is properly seated in the groove prior to fully installing the fuel pump assembly.
17. Rotate the pump assembly to align the "C" marking on the outlet cap with the "Locator" marking on the tank. **Note: Ensure these two markings are properly aligned prior to securing the lock ring, the fuel level sender will read incorrectly if the markings are misaligned.**



18. Once the markings are properly aligned, secure the pump assembly to the tank with the provided lock ring. **Note: The OEM "Hat" style lock ring will interfere with the ports on the outlet cap and should not be used.**

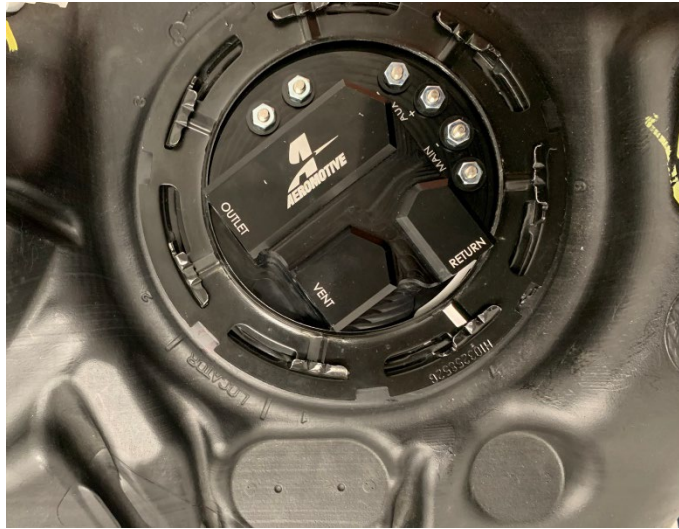

19. Install the provided 5/8" quick connect fitting in the -08 ORB Vent Port on the outlet cap. Then re-install the external vent tube on the outside of the tank that was removed during disassembly. Secure the quick connect fitting and push the tube back into the OEM tank groove as shown in the below images.

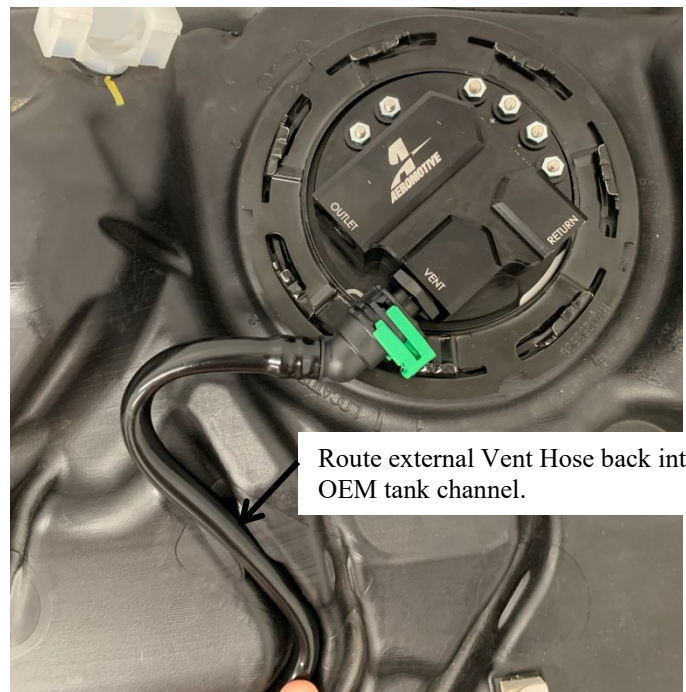
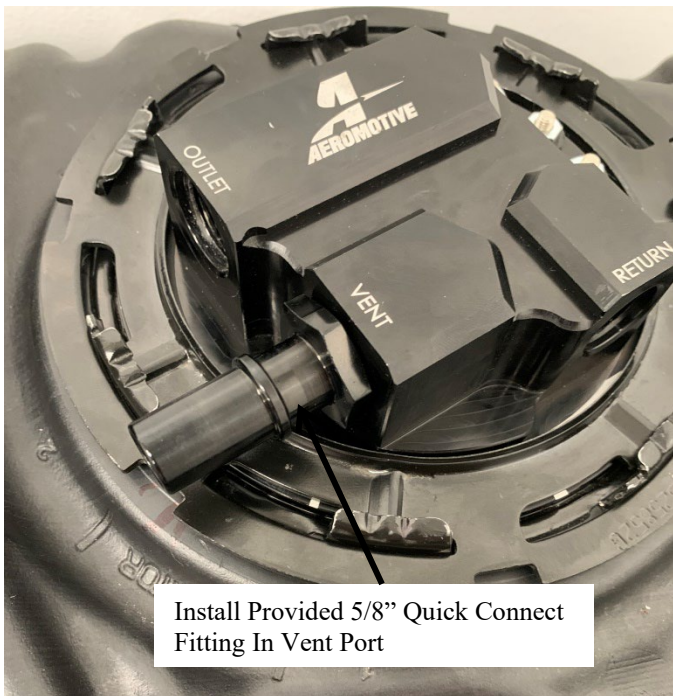

20. **As mentioned above, upgraded wiring is required to power the new pumps, wiring the pumps to feed the OEM direct injection fuel system to work in conjunction with the supplemental fuel system should only be performed by an experienced tuner/installer.** Connect electrical power (12 VDC) to each of the fuel pump power terminals. Make sure you use stranded, insulated copper wire, in the sizes shown, with matching crimp-type connectors for all connections. **CAUTION: The pump must be connected through a fused power source and not connected directly to the battery.** Connect each of the Aeromotive fuel pumps as shown in the following diagram: **NOTE: ONE RELAY AND FUSE PER PUMP "SIDE" (MAIN OR AUXILIARY TERMINALS).**

Wiring (per Pump)

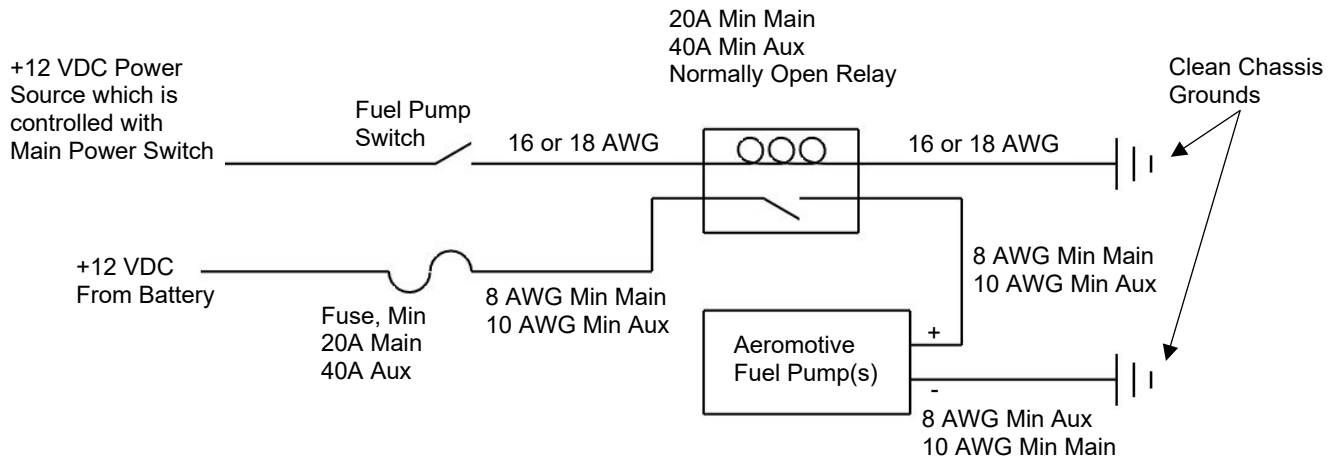

21. Install outlet and return port fittings using recommended AN ORB to AN male flare fittings. Run all necessary increased/upgraded plumbing and wiring to the outlet cap. **Note: A 150 degree -10 or -08 hose end works best to route the fuel feed line out of the outlet cap. A -08 90 degree hose end works best to route the return fuel line from the outlet cap. See the image below for an example of hose routing.** Route the fuel lines under the vehicle being sure to keep them away from heat and moving suspension components. Each pump (for 18075/18076 kits) will need its own relay and power wire. Aeromotive offers wiring kits, p/n 16307 and 16308, which may be used.

Feed Line with 150 degree hose end.
150 Degree Hose End Part Numbers:
-10 PTFE – Fragola PN: 681510BL
-10 Rubber – Fragola PN: 231510 BL
-08 PTFE – Fragola PN: 681508BL
-08 Rubber – Fragola PN: 231508BL

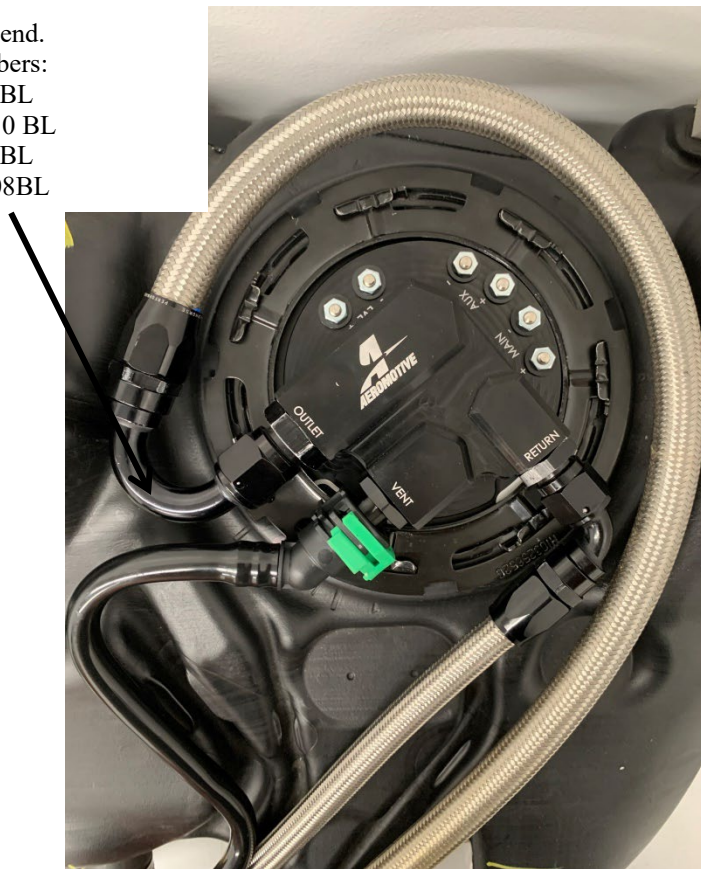

CAUTION: While performing the following steps, if any fuel leaks are detected, immediately turn the fuel pump OFF, remove any spilled fuel and repair the leak(s) before proceeding!

22. Turn the fuel pump(s) ON **without starting the engine**, allow the pump to run for several seconds and check the fuel pressure. If there is no pressure, turn the fuel pump OFF, wait one minute, then turn the fuel pump ON and recheck the pressure. Repeat this fuel pump OFF and ON procedure until the fuel pressure gauge registers pressure or you detect a fuel leak. It may be necessary to loosen the fuel line fitting at the pressure regulator to bleed off excessive air in the system. Tighten any fuel line fittings which were loosened and ensure that any spilled fuel is cleaned up and removed from the vicinity of the vehicle. If no pressure is registered on the gauge after running the pump for several seconds and you have found no leaks, check all fuel and electrical connections to determine the cause.
23. Once the fuel pressure gauge registers pressure, start the engine. The gauge on the fuel pressure regulator should register between 35 and 60 psi. Adjust the fuel pressure regulator to the desired setting.
24. Test drive the vehicle to ensure proper operation and re-check the fuel system for leaks. **If any leaks are found, immediately discontinue use of the vehicle and repair the leak(s)!**

Contact Us

RGA NUMBER REQUIRED FOR ALL RETURNS TO AEROMOTIVE.

To obtain an RGA number, please call (913) 647-7300 and ask for the Returns and Repairs department or complete the online form under the "Rebuilds" section at www.aeromotiveinc.com.

- **Shipping & Returns**
Aeromotive Inc.
10955 Mill Creek Road
Lenexa, KS 66219

General Inquiries and Tech Line: (913) 647-7300

General Email: info@aeromotiveinc.com

Tech Email: tech@aeromotiveinc.com

The Aeromotive Tech Lines are open Monday through Friday from 9:30AM to 5:00PM Central Standard Time.



WARNING: This product can expose you to chemicals, including chromium, which is known to the State of California to cause cancer or birth defects or other reproductive harm. For more information, visit: www.p65Warnings.ca.gov

AEROMOTIVE, INC. LIMITED WARRANTY

This Aeromotive Product, with proof of purchase dated on or after January 1, 2003, is warranted to be free from defects in materials and workmanship for a period of one year from the original date of purchase. No warranty claim will be valid without authentic, dated proof of purchase.

This warranty is to the original retail purchaser and none other and is available directly from Aeromotive and not through any point of distribution or purchase.

If a defect is suspected, the retail purchaser must contact Aeromotive directly to discuss the problem, possible solutions and obtain a Return Goods Authorization (RGA), if deemed necessary by the company. Please call 913-647-7300 and dial option 3 for the technical service dept. All returns must be shipped freight pre-paid to the company and with valid RGA before they will be processed.

Aeromotive will examine any product returned with the proper authorization to determine if the failure resulted from a defect or from abuse, improper installation, misapplication or alteration. Aeromotive will then, at it's sole discretion, return, repair or replace the product.

If any Aeromotive product is determined defective, buyer's exclusive remedy is limited in value to the sale price of the good. In no event shall Aeromotive be liable for incidental or consequential damages.

Aeromotive expressly retains the right to make changes and improvements in any product it manufactures and sells at any time. These changes and improvements may be made without notice at any time and without any obligation to change the catalogs or printed materials.

Aeromotive expressly retains the right to discontinue at any time and without notice any Aeromotive product that it manufactures or sells.

This warranty is limited and expressly limits any implied warranty to one year from the date of the original retail purchase on all Aeromotive products.

No person, party or corporate entity other than Aeromotive shall have the right to: determine whether or not this Limited Warranty is applicable to any Aeromotive product, authorize any action whatsoever under the terms and conditions of this Limited Warranty, assume any obligation or liability of any nature whatsoever on behalf of Aeromotive under the terms and conditions of this Limited Warranty.

This Limited Warranty covers only the product itself and not the cost of installation or removal.

This Limited Warranty is in lieu of and expressly excludes any and all other warranties, expressed or implied. This Limited Warranty gives you specific legal rights, and you may also have other rights which vary from state to state.