



LIMITED WARRANTY

PerTronix, Inc. warrants to the original Purchaser of its solid-state ignition system (product) that the Ignitor shall be free from defects in material and workmanship for a period of (30) months from the date of purchase.

If within the period of the foregoing warranty PerTronix finds, after inspection, that the product or any component thereof is defective, PerTronix will, at its option, repair such products or component or replace them with identical or similar parts PROVIDED that within such period Purchaser:

1. Promptly notifies PerTronix, in writing, of such defects.
2. Delivers the defective products product or component to PerTronix (Attn: Warranty) with proof of purchase date; and
3. Has installed and used the product in a normal and proper manner, consistent with PerTronix printed instructions

THE FOREGOING LIMITED WARRANTY IS EXCLUSIVE AND IN LIEU OF ALL OTHER WARRANTIES, WHETHER EXPRESS OR IMPLIED, INCLUDING ANY IMPLIED WARRANTY OR MERCHANTABILITY OR FITNESS FOR A PARTICULAR PURPOSE.

THE FURNISHING OF A REPAIR OR REPLACEMENT COMPONENTS SHALL CONSTITUTE THE SOLE REMEDY OF PURCHASER AND THE SOLE LIABILITY OF PerTronix WHETHER ON WARRANTY, CONTRACT OR FOR NEGLIGENCE, AND IN NO EVENT WILL PerTronix BE LIABLE FOR MONEY DAMAGES WHETHER DIRECT OR CONSEQUENTIAL.



440 East Arrow Highway
San Dimas, California 91773
(909) 599-5955



INSTALLATION INSTRUCTIONS FOR LU-281

Before installing, please read the following important information...

1. The Ignitor is designed for 12-volt negative ground systems.
2. The Ignitor is compatible only with a "points style" coil. A minimum total primary resistance of 1.5 ohms is necessary.
3. Caution: never use a "HEI" type coil with the Ignitor. This type of coil will damage the module, cause it to fail, and void the warranty.
4. If your ignition system presently is equipped with a ballast resistor, do not remove it.
5. The red wire from the Ignitor should be connected to the positive (+) side of the coil, or a 12-volt switching power source. (See Figure 2 & 3). The black wire must be connected to the negative (-) side of the coil.

FIGURE A



FIGURE B

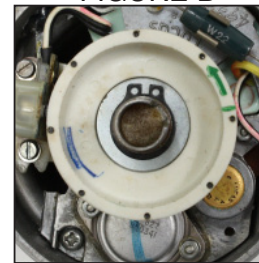

FIGURE C



1. Turn the ignition switch off and disconnect the battery.
2. If equipped, disconnect the ignition amplifier. Remove the amplifier from the vehicle.
3. Remove the distributor cap, rotor and dust cover.
4. For 35DM (CEI equipped) distributors remove the external module and module mounting bracket. (See Illustration A)
5. Remove the snap ring and washer at the top of the trigger wheel. (See Illustration B)
6. Remove the trigger wheel from the distributor. 35DM distributors remove the small plastic drive ring from the distributor shaft. (See Illustration C)
7. Remove the three screws around the pickup plate assembly and remove the entire assembly from the distributor.
8. Clean the inside of the distributor housing and distributor shaft.
9. Install the Ignitor and plate assembly into the distributor. Line up the vacuum advance pin with the vacuum advance arm.
10. Using the original hardware, attach the loose end of the ground wire to the nearest hold down screw. Tighten the plate in place with the remaining hardware.
11. Slide the wire grommet into the slot in the distributor housing.
12. **35DE (Opus) distributors:** Attach the magnet sleeve extender to the bottom of the magnet sleeve. One tooth is larger and must be aligned properly. Install the assembly onto the distributor shaft. Line up the large tooth with the large slot in the distributor shaft and press down firmly. 35DM (CEI) distributors do not use the magnet sleeve extender.
13. Install the distributor rotor and cap.

WIRING INSTRUCTIONS

1. Connect the Ignitor black wire to the negative (-) side of the ignition coil.
2. For installations that do not use a primary ballast resistor, connect the Ignitor red wire to the positive (+) side of the ignition coil. (See Figure 1)
3. For installations that use a primary ballast resistor, connect the red wire to the ignition switch side of the resistor. (See Figure 2).
4. Reconnect battery and make sure all wires are connected properly.
5. The engine can now be started. Let the engine run for a few minutes and then set the timing in the conventional manner.



FIGURE 1
WIRING DIAGRAM
IGNITOR SYSTEM
WITHOUT BALLAST RESISTOR

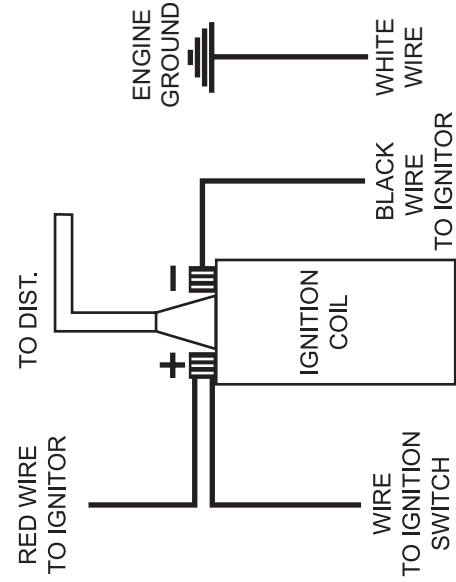
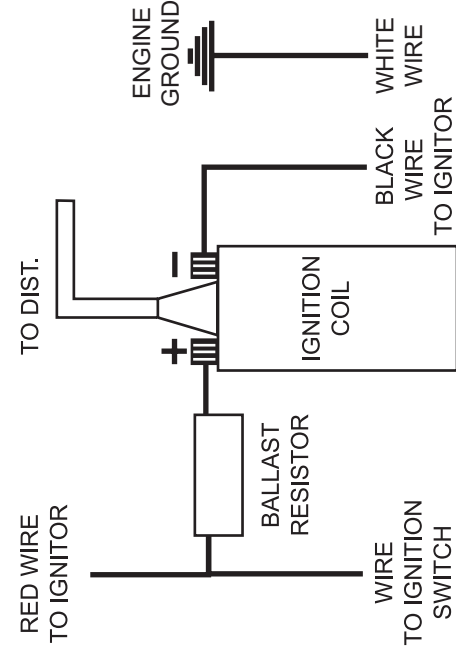

FIGURE 2
WIRING DIAGRAM
IGNITOR SYSTEM
WITH BALLAST RESISTOR



NOTE: A RESISTOR WIRE OR BALLAST RESISTOR MAY OR MAY NOT BE INCLUDED IN THE ORIGINAL EQUIPMENT.