

## LIMITED WARRANTY

PerTronix, Inc. warrants to the original Purchaser of its solid-state ignition system (product) that the Ignitor shall be free from defects in material and workmanship for a period of (30) months from the date of purchase.

If within the period of the foregoing warranty PerTronix finds, after inspection, that the product or any component thereof is defective, PerTronix will, at its option, repair such products or component or replace them with identical or similar parts PROVIDED that within such period Purchaser:

1. Promptly notifies PerTronix, in writing, of such defects.
2. Delivers the defective products product or component to PerTronix (Attn: Warranty) with proof of purchase date; and
3. Has installed and used the product in a normal and proper manner, consistent with PerTronix printed instructions

THE FOREGOING LIMITED WARRANTY IS EXCLUSIVE AND IN LIEU OF ALL OTHER WARRANTIES, WHETHER EXPRESS OR IMPLIED, INCLUDING ANY IMPLIED WARRANTY OR MERCHANTABILITY OR FITNESS FOR A PARTICULAR PURPOSE.

THE FURNISHING OF A REPAIR OR REPLACEMENT COMPONENTS SHALL CONSTITUTE THE SOLE REMEDY OF PURCHASER AND THE SOLE LIABILITY OF PerTronix WHETHER ON WARRANTY, CONTRACT OR FOR NEGLIGENCE, AND IN NO EVENT WILL PerTronix BE LIABLE FOR MONEY DAMAGES WHETHER DIRECT OR CONSEQUENTIAL.



440 East Arrow Highway  
San Dimas, California 91773  
(909) 599-5955

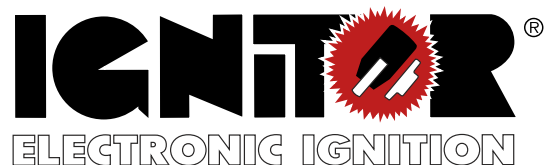

Installation Instructions  
Part # 1247XTP6

### BEFORE YOU START

- Read the complete instruction manual before starting installation.
- This system is for 6 volt positive ground systems only.
- This kit is designed to fit N-Series Ford tractors with front mount distributors.
- Some modification to the original distributor is necessary.
- A minimum primary resistance of 1.5 ohms is required.

### Removing the distributor

1. Disconnect the coil power wire.
2. Remove the spark plug wires from the distributor cap.
3. Remove the coil by unsnapping the retainer bail.
4. Unsnap and remove the distributor cap.
5. Note the position of the rotor so that the distributor can be reinstalled in the same position. Remove the rotor.
6. Remove the two bolts that hold the distributor to the block.
7. Remove the distributor.

### Removing the breaker plate

1. Remove the breaker plate retaining ring.
2. Remove the condenser and screw.
3. Remove the breaker plate hold down screw.
4. Remove the breaker plate.
5. Remove the shim washer from the distributor shaft.
6. Remove the distributor shaft and advance mechanism.
7. Check the distributor for cracks and excess wear.
8. Re-install the advance mechanism and shaft back into the distributor.

### Ignitor module installation

1. Install the magnet sleeve onto the point cam.
2. Install the shim washer onto the distributor shaft.
3. Set the adapter plate it into the distributor. Insert the provided hold down stud through the plate and distributor housing.
4. Install the timing adjustment slide over the stud. Install the provided lock nut.

- Static time the distributor by positioning the plate so that the slide is positioned in the middle of the adjustment slot. The adjustment nut should be centered with the cap spring clip (See Illustration B). Tighten the nut once it is aligned properly.
- Install the plate retaining ring. The flat portion of the ring should be placed on adjustment slot side of the distributor.

#### Distributor Installation

- Install the rotor.
- Turn the rotor to the position that was noted prior to the removal of the distributor.
- Place distributor into block and fasten in place with the original mounting bolts. Note: Do not force the distributor into place. Check to make sure that drive tang is properly aligned.

#### External Coil Installation

- Use the provided coil bracket to mount the coil to the engine. Choose a mounting place that will hold the coil upright and prevent the wires from contacting moving parts.

#### Wiring

- Feed the black and black/white Ignitor wire through the opening where the original coil was mounted.
- Insert the wires through the hole in the coil block off plate. Pull the grommet into place.
- Install the provided distributor cap. This cap has been modified to accept a screw in terminal.
- Place the coil block off plate into position. Use the provided screw and washer to mount the plate to the distributor body.
- Place the two shim washers and the plastic spacer onto the threaded terminal and screw it into the distributor cap.
- Attach the black/white Ignitor wire to the negative coil terminal. (See Illustration C)
- Attach the ignition switch wire directly to the Ignitor black wire. (See Illustration C)
- Using 18 gauge wire or larger, connect the coil positive terminal to an engine ground.
- Install the provided coil plug wire.

Illustration B

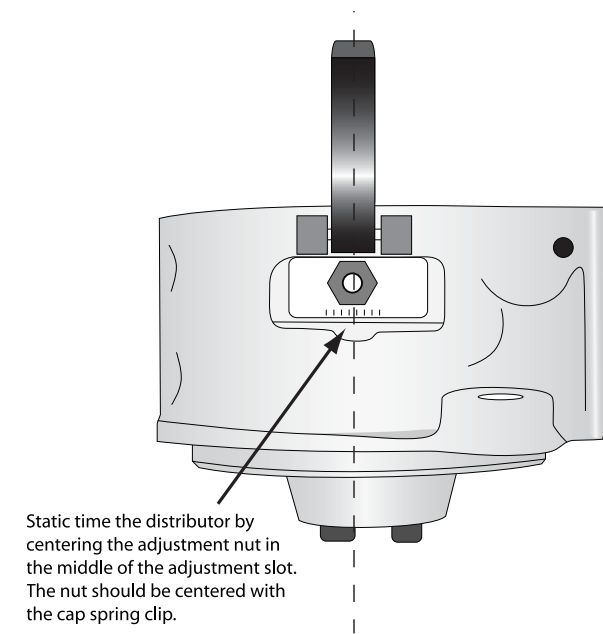

Illustration C

