



**AEROMOTIVE**  
**Part # 19122, 19123, 19124, 19125, 19126, and 19127**  
**1967-1972 C10 Chevy Truck Rear Mount Tank**  
**INSTALLATION INSTRUCTIONS**

This product is not legal for sale or use on emission-controlled vehicles except when used as a direct replacement part matching OEM specification.

**WARNING!**



Always be aware of flammable situations. Drilling and grinding can be potential ignition sources. Extinguish all open flames, prohibit smoking and eliminate all sources of ignition in the area of the vehicle and workspace before proceeding with the installation. Ensure you are working in a well-ventilated area with an approved fire extinguisher nearby.

**WARNING!**



etc.

Installation of this product requires modification to a fuel tank/ the fuel system, failure to satisfy all safety considerations will result in fire, explosion, injury and/or loss of life to yourself and/or others. All fuel system components **MUST** be located as far from heat sources as possible, like exhaust, engine block,

**WARNING!**



Mechanical and hydraulic lifting devices can tip over or lower accidentally due to incorrect maneuvering or technical errors. A falling object can cause injury and/or loss of life to yourself and/or others. When working under the vehicle, always use stands, and ensure that the ground or floor is stable and level. Never crawl under a vehicle which is only supported by a jack.

**WARNING!**



The fuel system is under pressure. Do not open the fuel system until the pressure has been relieved. Refer to the appropriate vehicle service manual for the procedure and precautions for relieving the fuel system pressure.

**CAUTION!**



When installing this product always wear safety glasses and other appropriate safety apparel. A drilling operation will cause flying metal chips. Flying metal chips can cause eye injury.

**CAUTION:**



Installation of this product requires detailed knowledge of automotive systems and repair procedures. We recommend that this installation be carried out by a qualified automotive technician. Careless installation of this product can result in damage to the product, injury or loss of life to yourself and/or others.

## Compatible Fuels:

Pump Gas  
Race Gas  
E85  
Alcohol/Ethanol

To use this stealth fuel tank in your vehicle's fuel system, **you must do the following:**

- **A bypass style fuel pressure regulator must be used in the system.**
- **Utilize high pressure fuel lines, fittings and o-rings for all connections from the fuel tank to the fuel pressure regulator.**
- **For long-term driving applications where continuous run times exceed 30 minutes Aeromotive recommends maintaining at least a half-full tank of fuel.**

**Failure to follow the above may result in fuel leakage, bursting of the fuel lines, poor vehicle performance and/or decreased fuel pump life! Improper installation will void all warranties for this product!**

Aeromotive system components are not legal for sale or use on emission-controlled motor vehicles.

The enclosed Aeromotive fuel pump and return port utilizes an AN-10 ORB (O-ring Boss Ports) style outlet/inlet port; these ports are **NOT PIPE THREAD** and utilize **NO THREAD SEALANT**.

Connect the fuel pump outlet to a fuel filter, Aeromotive p/n 12350 or 12339 (10 micron). **Make sure you use high pressure (150 psi minimum) fuel line for this connection!**

For AN-12 Line, Aeromotive p/n 15642, (AN-10 ORB to AN-12 Flare Union)

For AN-10 Line, Aeromotive p/n 15608, (AN-10 ORB to AN-10 Flare Union)

For AN-08 Line, Aeromotive p/n 15610, (AN-10 ORB to AN-08 Flare Union)

For AN-06 Line, Aeromotive p/n 15609, (AN-10 ORB to AN-06 Flare Union)

Maximum continuous operating pressure should not exceed 70 psi.

If you are running an EFI System, connect the fuel filter outlet to the fuel rail(s) and then to a bypass style fuel pressure regulator as in the following diagrams. **Make sure you use high pressure (150 psi minimum) fuel line for these connections!** For optimum fuel system performance in EFI applications, Aeromotive recommends a balanced system with the fuel pressure regulator as the last component in the system as shown in the following diagrams.

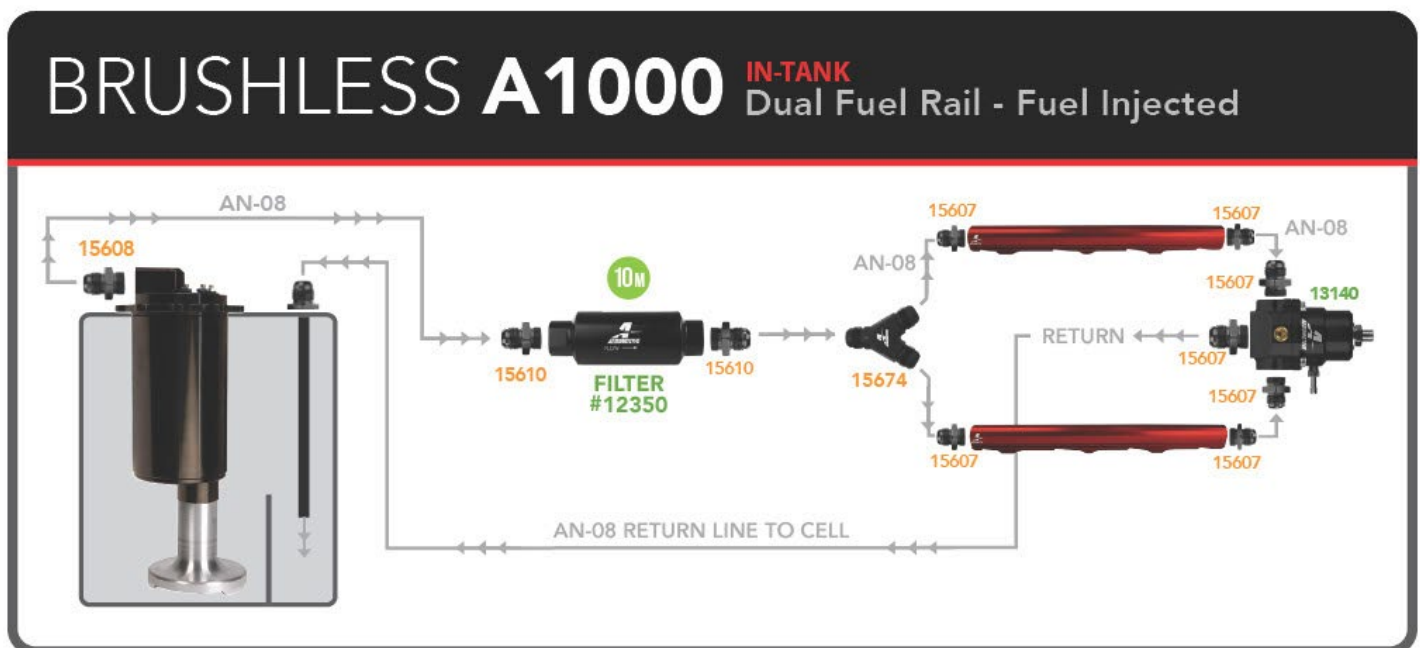

# BRUSHLESS ELIMINATOR IN-TANK Dual Rail - Fuel Injection

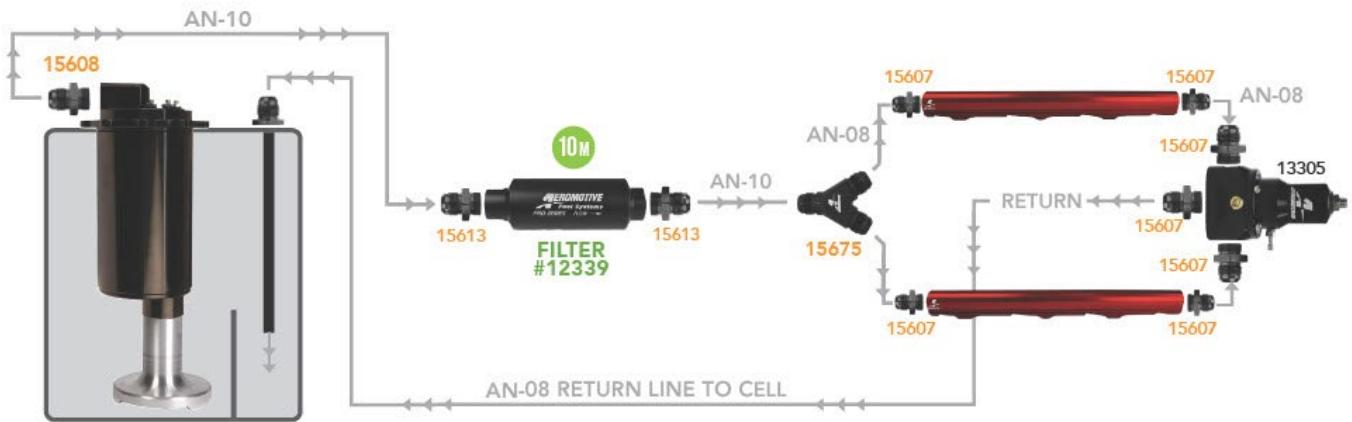

# 3.5 BRUSHLESS GEAR PUMP IN-TANK Dual Rail - Fuel Injection

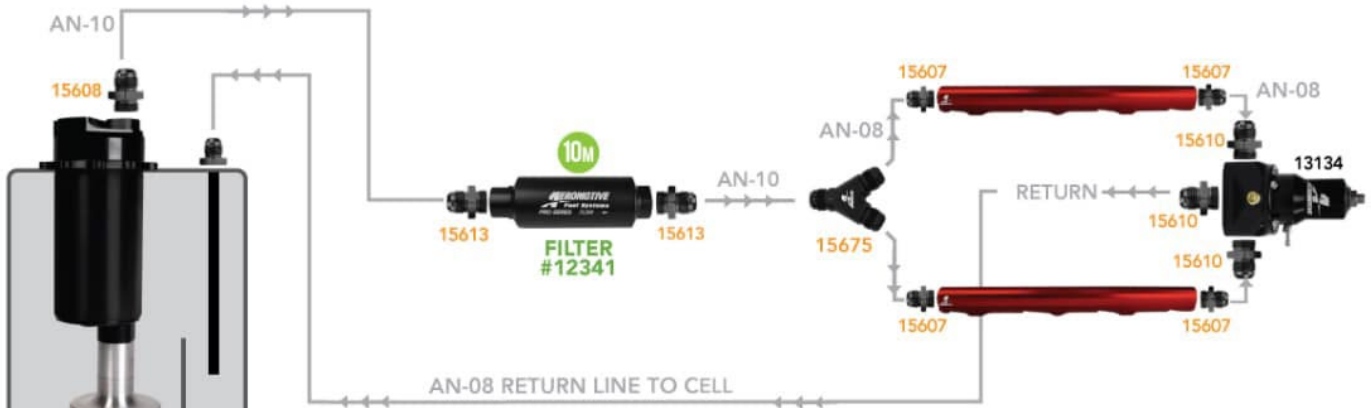

# 5.0 BRUSHLESS GEAR PUMP **IN-TANK** Dual Rail - Fuel Injection

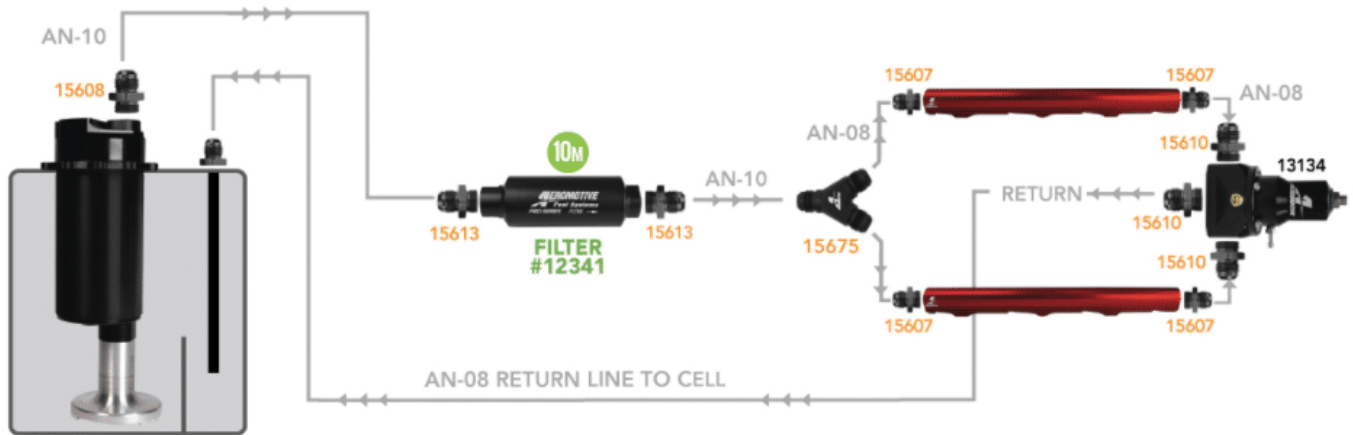

# 7.0 BRUSHLESS GEAR PUMP

DUAL RAIL - FUEL INJECTION **IN-TANK**

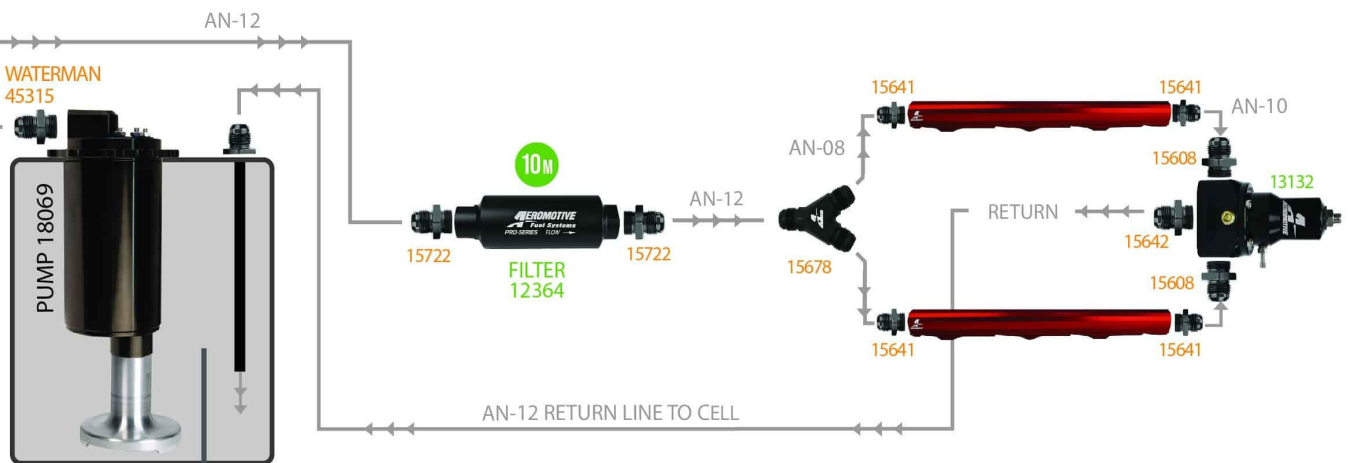

# 10.0 BRUSHLESS GEAR PUMP

DUAL RAIL - FUEL INJECTION **IN-TANK**

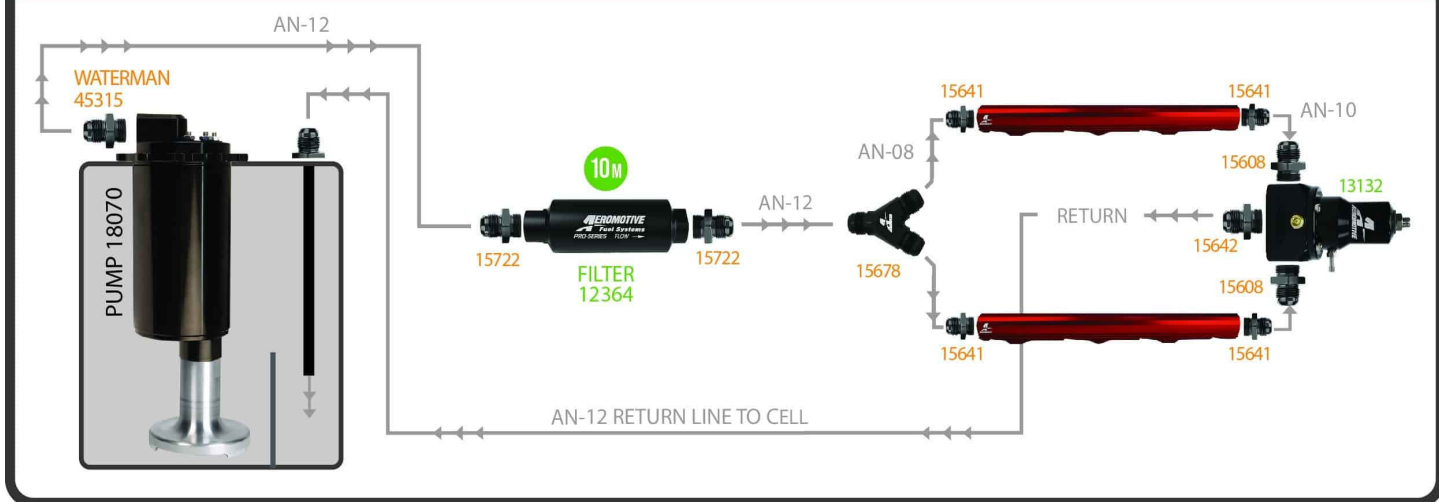

## Suggested Wiring Kit:

PN: 16307 (Use with PN's 19122, 19123, and 19124.)

PN: 16308 (Use with PN's 19125, 19126, and 19127.)

Failure to follow the above recommendations may result in fuel leakage, bursting of the fuel lines, poor vehicle performance and/or decreased fuel pump life! Improper installation will void all warranties for this product!

**Tank Fuel Level Sender: 0-90 Ohm Range**

**Tank Capacity: 17gal**

## Tools Required for Typical Installation

Drill  
1/4" Drill Bit  
5/8" Drill Bit  
2 1/4" Metal Hole Saw  
Tape Measure  
Hammer  
Scissors or Utility Knife  
Center Punch  
Small "C" Clamps  
Die Grinder with Deburr Bit or Round File  
5/16 Nut Driver  
9/16" Socket and Ratchet  
9/16"  
Phillips Head Screwdriver or Bit for Drill  
Floor Jack and Jackstands (If not using a lift)

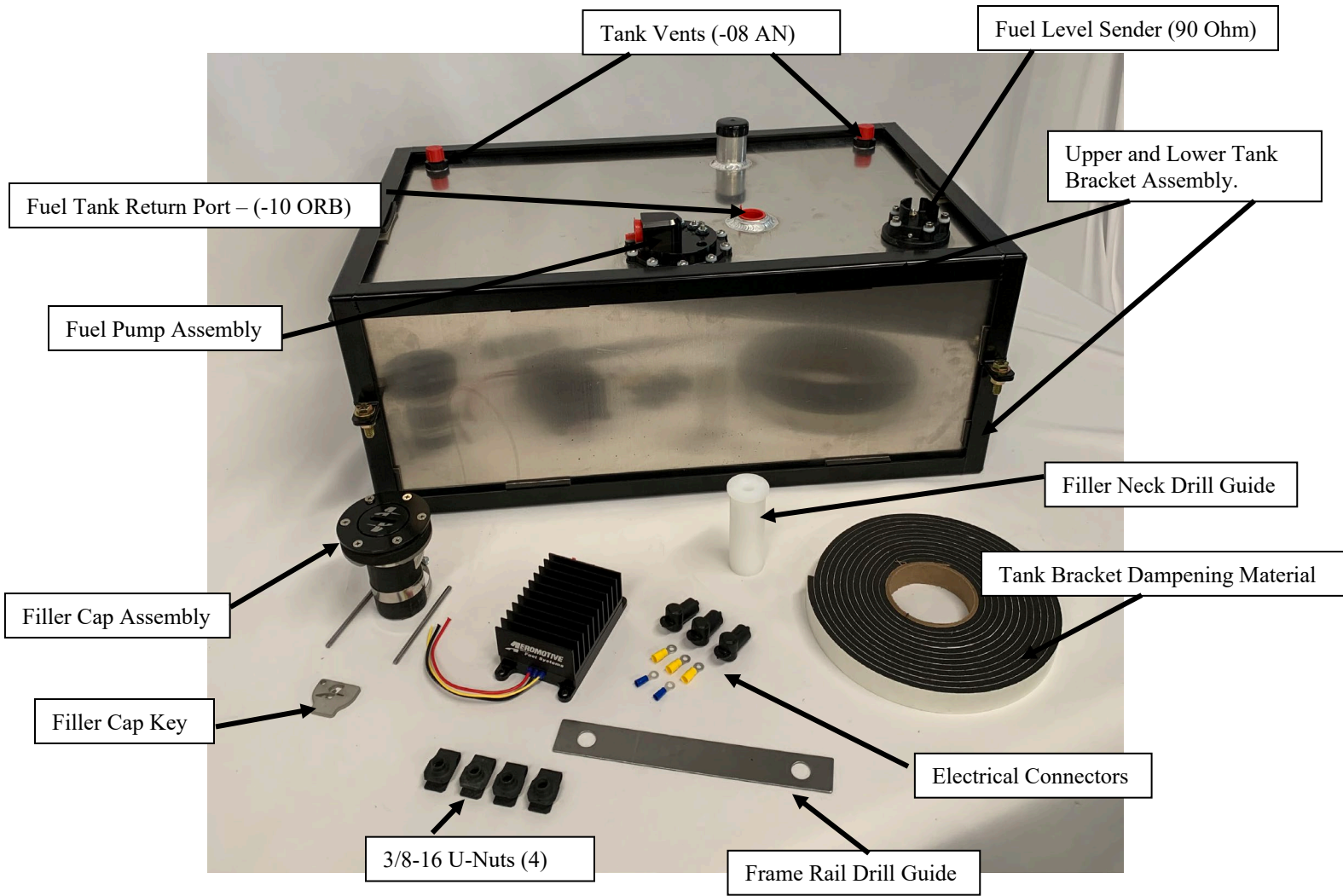

**Typical Installation Procedure**

1. Disconnect negative “-” post of battery.
2. Following a vehicle specific repair manual, drain and remove the OEM fuel tank located behind the seat in the cab. The OEM fuel lines can be removed as well and will not be used during re-assembly. Clean up any spilled fuel around the work area.
3. Once the OEM tank is removed from the vehicle, raise and support the vehicle with either a vehicle lift or a jack and jackstands. Ensure the vehicle is properly supported before working underneath it.
4. Using the tape measure, make a mark on the bottom of the driver’s side frame rail measured from the back of the rear crossmember forward 6 3/8”. This will be the reference mark for the frame rail drill guide. See pictures below.



Measure Forward From Back Edge of Rear Crossmember

5. Line the back of the frame rail drill guide up with the mark on the frame, the frame rail drill guide should be flush with the inside of the frame rail, once in position, use the clamp to hold in place. See pictures below.



6. Mark the holes on the bottom of the frame rail with the sharpie or marker, repeat this process for the passenger side of the vehicle.

7. Once the holes are marked on both sides of the frame rail, carefully raise the top tank bracket in the vehicle and line up the holes on the upper tank bracket with the marks on the frame rail. It is helpful to use c-clamps to secure the bracket to the frame while checking for clearance. Check for bracket interference with the front or rear crossmember, if the bracket does not interfere with either crossmember or frame rail, drop the bracket back down.



8. If the drill hole locations are verified, center punch the holes and first drill a  $\frac{1}{4}$ " pilot hole, then drill the hole to the finish diameter of  $\frac{5}{8}$ ". Then use the die grinder or round file to deburr the holes.

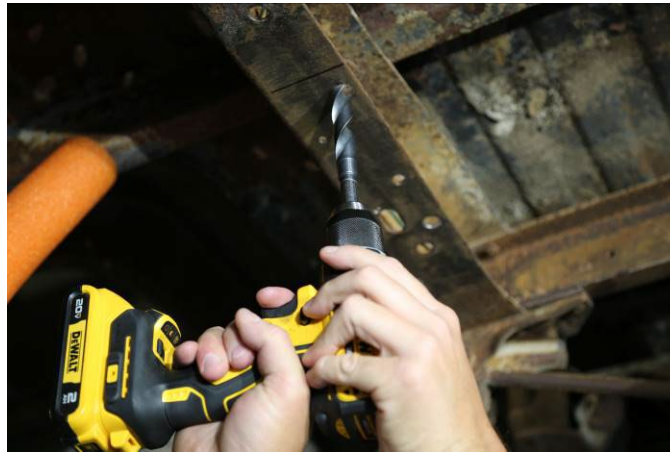

9. Next, install the four u-nuts on the frame rail holes as shown in the picture below.



10. Next, cut 2"-3" long strips of the provided  $\frac{1}{4}$  x 1" foam strips, these are used as a vibration dampener between the bracket and the tank. Place the strips intermittently on the inside of the bracket, alternating surfaces as shown below. Repeat this process on the bottom bracket. **(Note: The strips are not intended to be installed continuously on the bracket as this can trap water and debris, alternating positions and surfaces with the strips allows water and debris to escape.)**

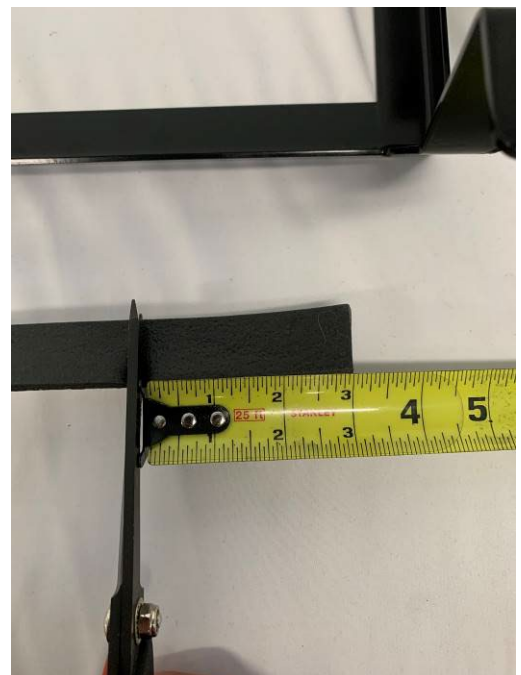

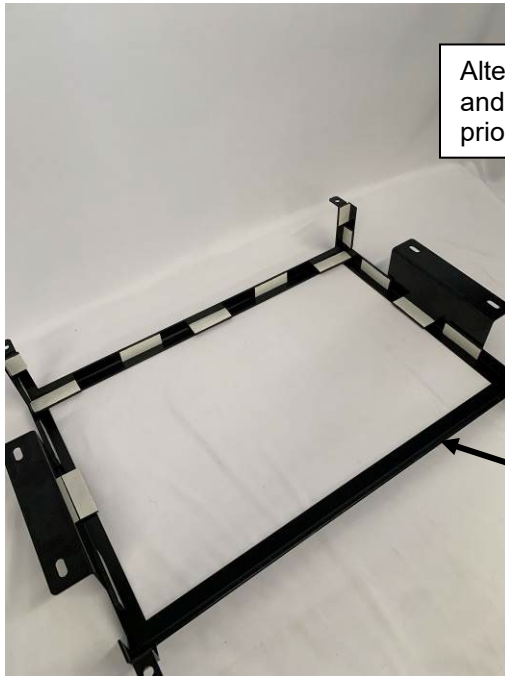

Alternate placement of foam strips on top and bottom bracket. Peel white film off strips prior to tank installation.

Top Tank Bracket.

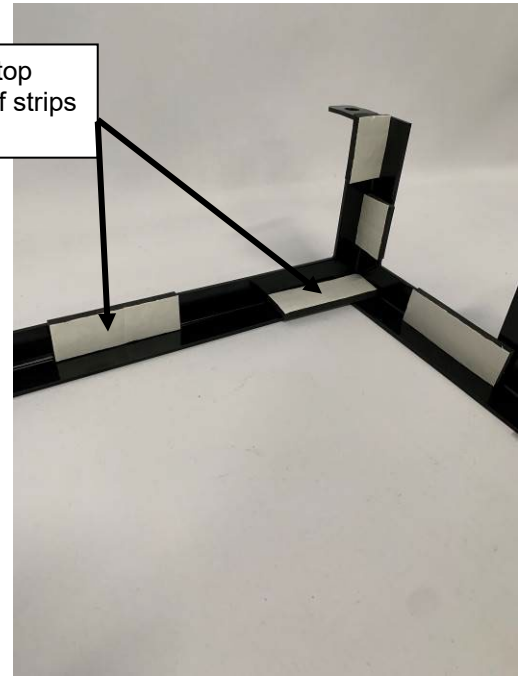

11. Once the top bracket has the foam strips attached, install the bracket in the frame of the truck using the supplied 3/8" bolts, washers, and lock washers. Ensure the bracket has clearance from the front and rear crossmembers. Tighten the bolts with a 9/16" socket or wrench.



12. Drop the fuel filler drill guide and sharpie marker in the tank filler neck as shown in the picture below. Then set the tank in the bottom tank bracket.



13. Use the floor jack to raise the tank/bottom bracket assembly up into the vehicle, line up the holes in the top and bottom bracket flange. Using the 4 - 3/8" x 1 1/4" bolts and 3/8" nuts, (one on each corner of the tank bracket) secure the bottom tank/bracket to the top tank bracket.

14. Reach in between the frame and the bottom of the bed to grab the drill guide, pick up on the drill guide until the sharpie contacts the bottom of the bed. Twist the drill guide or the sharpie to make a mark on the bottom of the bed floor. This is the center of the fuel filler cap and will give you the location of where to drill. See pictures below.



Lift Drill Guide Upwards until Marker makes Contact with the Bed Floor. Then Rotate Drill Guide/Marker to make a Mark on Bed Floor.

15. Remove the tank from the vehicle and verify a visible mark is on the bottom of the bed floor that corresponds to the tank filler neck location.

16. Center punch the mark on the bottom of the bed floor and drill a pilot hole with the 1/4" drill bit from the bottom of the bed floor.

17. Next, using the 2 1/4" metal hole saw, drill the hole for the fuel filler cap housing from the top of the bed floor using the pilot hole as the center. Deburr the hole with die grinder or round file once the hole is drilled.



18. Loosely install the filler cap in the hole as shown in the picture below. Use the cap as a guide to mark the six mounting holes for the filler cap housing. Center punch the holes and drill with the 1/4" drill bit. Deburr the holes once drilled.

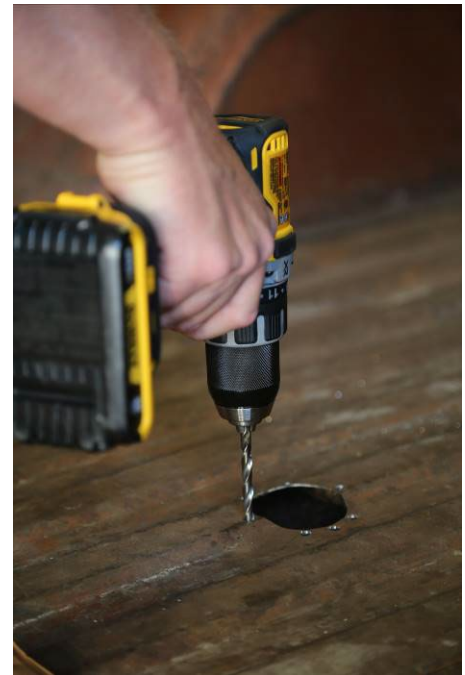

19. Insert the retaining ring through the hole and line up six holes in the bed with the threaded holes in the retaining ring. Using the two provided 10-24 x 4" studs, thread them into two of the six mounting holes, preferably two holes that are directly across from each other. Hold onto one of the studs to keep the retaining ring from falling. **Note: Have the gasket, filler cap housing, and screws nearby for this step.** See pictures below.



20. The studs are used as an installation tool and will be removed later during assembly.

21. Slide the gasket and filler cap housing over the studs and position on the bed floor. Once in position, start but don't fully tighten the 10-24 screws. Tighten in a cross pattern to start compressing the gasket. See pictures below.



22. Once four of the screws are started, remove the two studs and insert the two remaining screws in the holes. Now fully tighten the filler cap screws, they just need to be tight enough to compress the gasket and sit flush on the bed floor. Do not overtighten the screws to avoid damaging the housing. Next, install the fuel filler cap using the provided key. See pictures below.



23. From the underside of the bed, install the filler neck hose and tighten to the filler cap housing with one of the hose clamps. Now, very loosely tighten the second hose clamp near the bottom of the hose. Just to secure it in position for the tank filler neck, the clamp will be fully tightened once the tank is installed. **Note: Position the hex head from the hose clamp so it is facing towards the side of the truck, if it is positioned so the hex is facing the front or back of the truck, you won't be able to tighten it in a later step.** See pictures below.

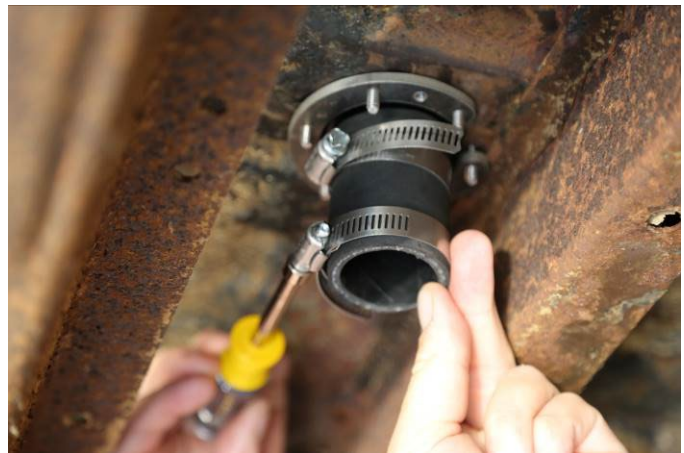

24. Next, run all fuel supply, return, and vent hoses to the tank area. You will want to leave enough hose length to make the hose connections on top of the tank prior to fully raising the tank in the vehicle. Run all electrical connections to the tank at this time as well. As with the hoses, leave enough length of wire to connect to the top of the tank prior to fully raising it into the vehicle. **(Note: See instructions below for the remote mount pump controller for mounting and wiring procedures.)**

25. Determine a suitable location to mount the controller remote from the pump considering the following:

- a) It is recommended to keep the controller-to-motor lead wire lengths as short as possible for best pump performance.
- b) If desired, motor lead extensions can be used but should be kept as short as possible and lead extensions should be sized large to keep electrical resistance low (you may even want to use a larger size for the extensions than the provided leads for long extensions).

- c) The controller is fully sealed so it can be mounted externally (frame rail, e.g.). The controller sink is designed to be able to handle low air flow so it can also be mounted internally (trunk, e.g.). However, for best results, it is recommended to mount the controller such that it will receive the most and coolest air flow.

When mounting the controller externally and in a location that will likely receive air flow from driving, mount the controller with fins parallel to the airflow and and, if possible, upward (not required with sufficient air flow) as in the following image.

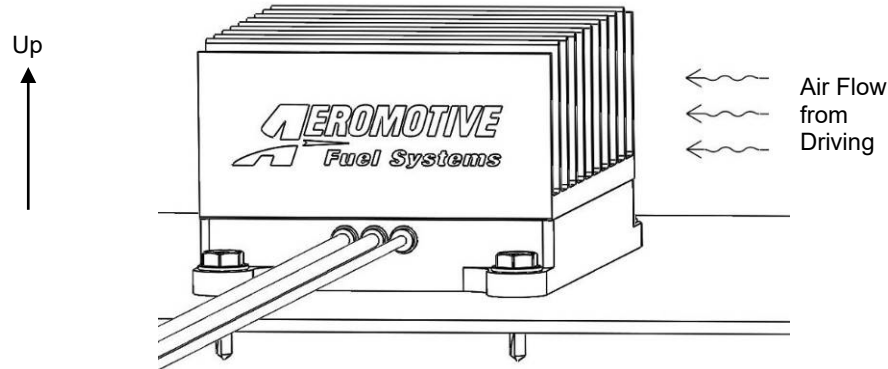

When mounting the controller internally or behind obstructions in a location that will not receive much air flow from driving, mount the controller with the fins vertically as in the following image to achieve the maximum natural convective cooling.

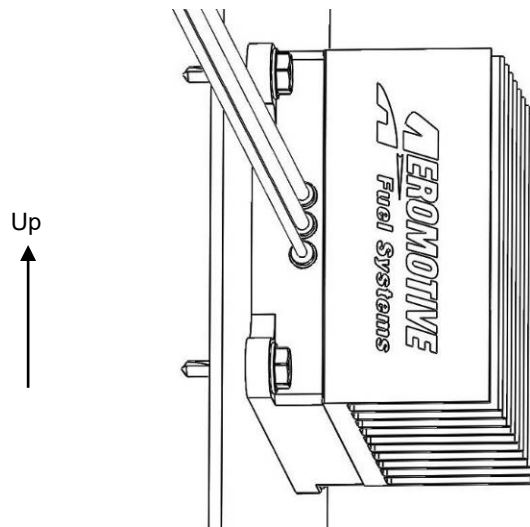

- d) **NOTE: THIS CONTROLLER CAN GET HOT** when using full power (60A rating) continuously with little air flow.  
**Mount away from locations prone to fuel vapor (e.g., tank vent).**

26. Once a suitable location is found, mount the controller in the recommended orientation using the four #10 self-drilling screws.

27. Crimp the #10 ring terminals to the motor lead wires after cutting to length if not using extensions.

28. Connect the three motor leads from the controller to the pump matching the colors to the engravings (In most cases, the black lead connects to the “B”, red to “R”, and white/gray to “W”). Secure connections using the #10-32 nuts installed on the pump outlet cap, firmly holding the terminal end in place while tightening.

29. Connect the fuel pump as shown in the following diagram, +12VDC to the red lead, Ground to the black lead. To make installation easier, a kit is available, Aeromotive fuel pump wiring kit, part # 16307 or 16308. **NOTE: POWER TO THE PUMP MUST BE FLAT DC, NOT PULSE WIDTH MODULATED!**

**CAUTION: DO NOT REVERSE THE POLARITY-CONNECT AS STATED ABOVE. Reversing the polarity will render the controller inoperable and will void all warranties for this product!**

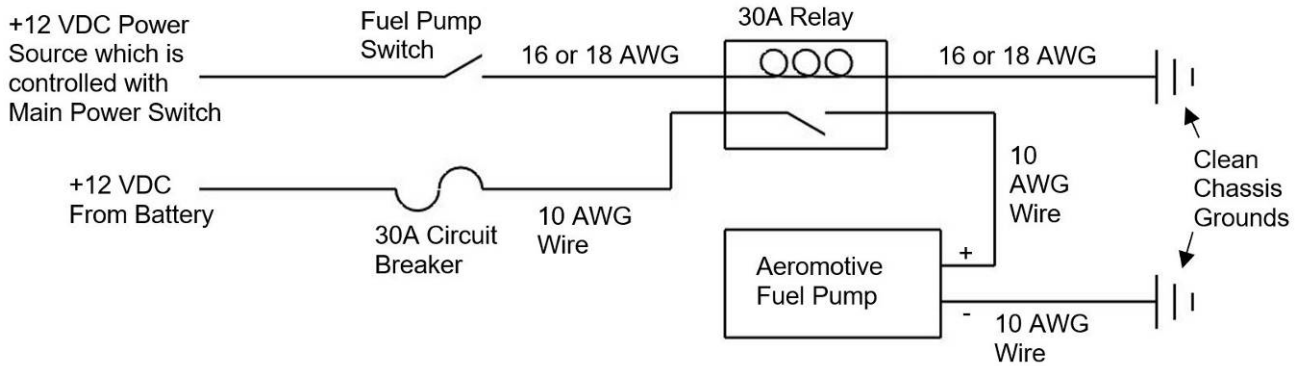

30. This pump controller allows the ability to change the speed of the pump via a 0-5VDC analog input to the yellow signal wire. **THE CONTROL SIGNAL MUST BE A TRUE ANALOG INPUT, NOT PWM.** A PWM signal can only be used if filtered sufficiently for smooth operation. The signal wire used to control the speed of the pump may be connected in ONE of multiple configuration examples as shown in the following illustrations to control the speed of the pump.

31. This pump controller has a minimum floor for pump speed of approximately 40% depending on the pump. This means that fuel pump speed will not fall below 40% of full speed with zero input voltage on the yellow control signal wire.

32. This pump controller has a minimum voltage threshold of approximately 0.5VDC. Voltage above 0.5VDC on the yellow input wire will increase the speed of the pump. Signal input of voltage below 0.5VDC will have no effect on pump speed. This ensures allowance for minimum, closed throttle TPS settings of up to 0.5VDC without affecting fuel pump speed at idle.

33. This pump controller has a full pump speed voltage threshold of approximately 3.7VDC, where the full pump speed will be achieved with signal input voltage at or above 3.7VDC and above which no further change in pump speed will occur. This ensures that when a TPS signal is used to drive pump speed that typical throttle openings of 70-75% and higher will ensure full fuel pump volume is delivered to the fuel rail or carburetor. Voltage between 0.5VDC and 3.7VDC will vary the speed of the fuel pump according to the voltage applied.

#### CONTROL CONFIGURATIONS:

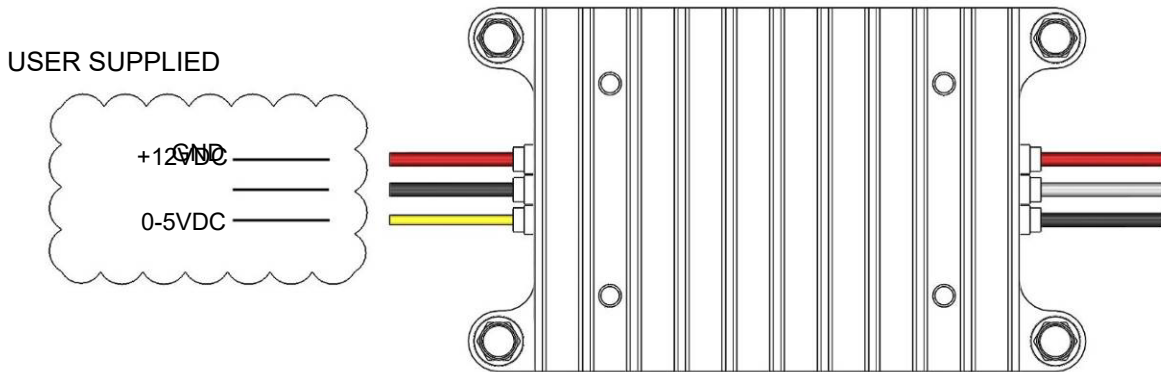

MODE 1 – TPS or Other 0-5VDC Input Control

Aeromotive recommends the “Mode 1” control method where the 0-5VDC signal input is tied to a Throttle Position Sensor using the output wire to the ECU. The intent for this control is to reduce the fuel pump output (and thus the amount of returned fuel flow) during low throttle opening (low engine demand) to reduce excess recycling of fuel to help keep fuel tank temperatures low. Alternatively, other 0-5VDC analog output sensors (some MAF sensors, a 2 or 3-Bar MAP sensor, etc.) or voltage dividing/regulating/switching components may be used. It is the customer’s responsibility to ensure a signal supply and control strategy where the fuel flow is sufficient to meet engine demand.

If no signal supply is suitable or desired, the controller can still be wired for use as in Modes 2 – 4, as shown following, to allow different fuel pump speed and flow outputs from the pump.

USER SUPPLIED

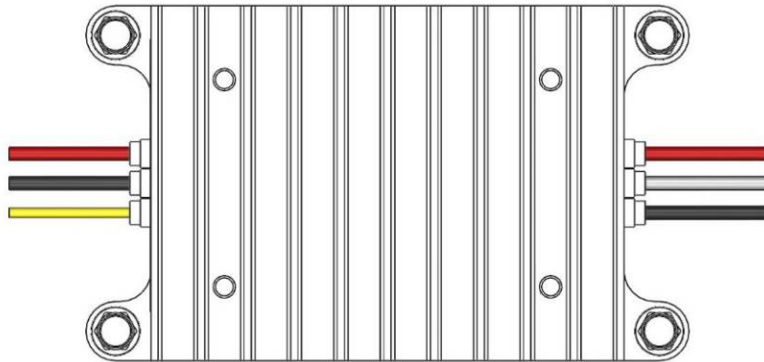
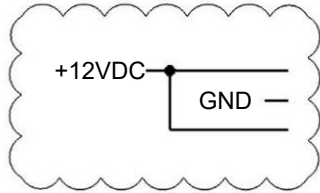

MODE 2 – Constant Full Speed

USER SUPPLIED

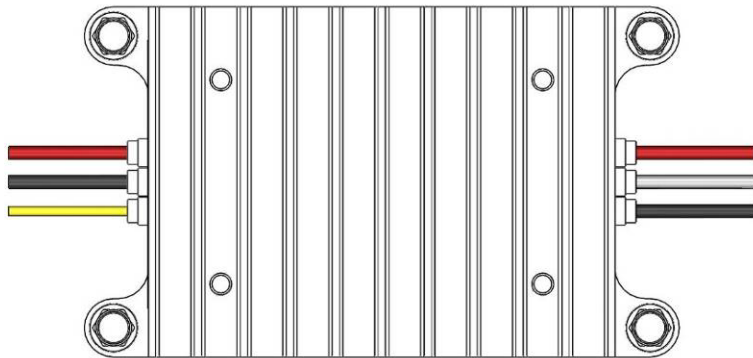
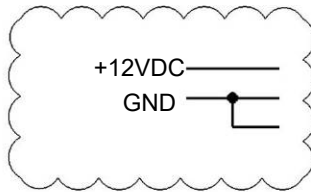

MODE 3 – Constant Low Speed

USER SUPPLIED

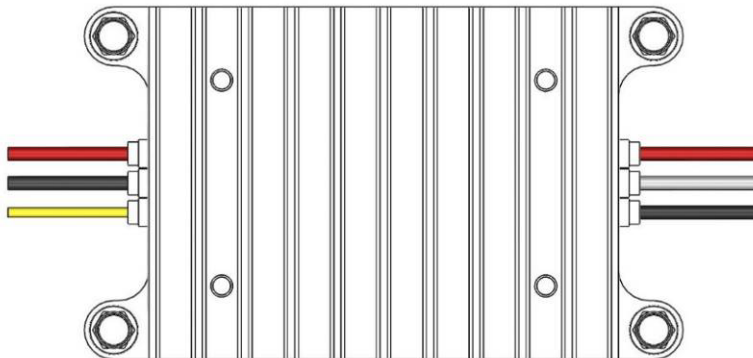
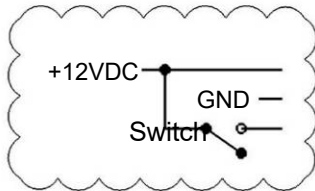

MODE 4 – Switched Speed On - Demand from Low to High

Mode 4 can be activated by any relay or switch providing 5VDC or higher (system voltage up to 19VDC is fine) to the control wire. A relay for this purpose could be activated using the programmable output from a tunable ECU, or via a boost Hobb's or WOT switch connected to 12VDC to name a few examples.

34. Connect the fuel sending unit output wire to a 0-90 ohm compatible fuel level gauge. 0 ohms reads empty, and 90 ohms reads full.

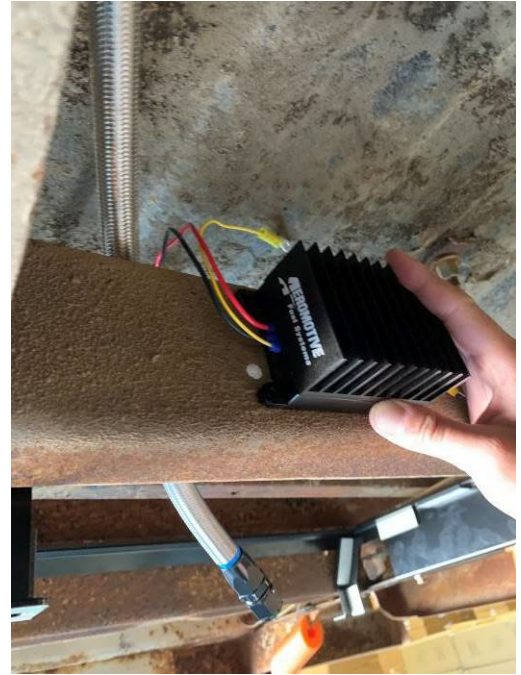

35. Connect all electrical and hose connections to the tank and raise the lower tank bracket and tank up with a jack into position, line it up with the tank bracket holes on the upper tank bracket. When raising the tank ensure the filler neck of the tank slides into the fuel filler hose. Keep the jack under the tank while you attach the lower tank bracket to the upper tank bracket using the supplied 3/8" x 1 1/4" bolts, washers, and nyloc nuts. Note: Ensure the filler neck hose is not distorted or wrinkled before fully raising the tank into position. **Note: See electrical schematic and information below.**

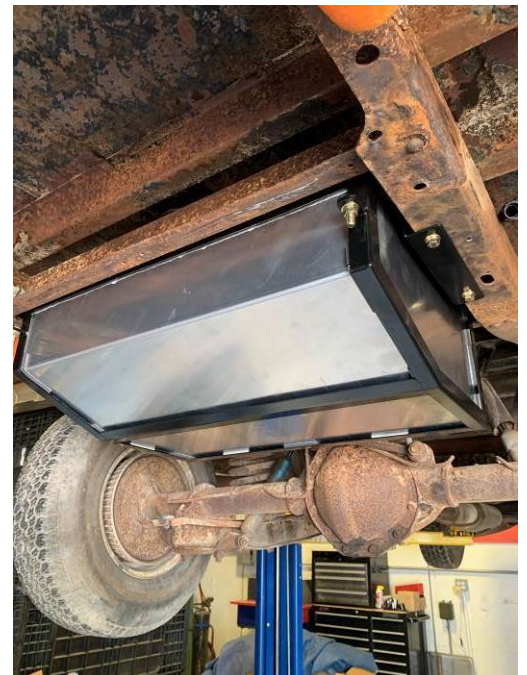

36. Once the tank is secured and the filler neck is aligned with the filler hose, reach in behind the bed crossmember and tighten the lower hose clamp with a 5/16 nut driver. See picture below.



**Note:** Be sure to route all electrical wires clear of any moving suspension or drivetrain components and any exhaust components! Protect wires from abrasion and road obstructions or debris.

**CAUTION:** While performing the following steps, if any fuel leaks are detected, immediately turn the fuel pump OFF, remove any spilled fuel and repair the leak(s) before proceeding!

37. Turn the fuel pump ON **without starting the engine**, allow the pump to run for several seconds and check the fuel pressure. If there is no pressure, turn the fuel pump OFF, wait one minute, then turn the fuel pump ON and recheck the pressure. Repeat this fuel pump OFF and ON procedure until the fuel pressure gauge registers pressure or you detect a fuel leak. If necessary, loosen the fuel line fitting at the pressure regulator to bleed off excessive air in the system. Tighten any fuel line fittings which were loosened and ensure that any spilled fuel is cleaned up and removed from the vicinity of the vehicle. If no pressure is registered on the gauge after running the pump for several seconds and you have found no leaks, check all fuel and electrical connections to determine the cause.

38. Once the fuel pressure gauge registers pressure, start the engine. The gauge on the fuel pressure regulator should register between 3 and 12 psi for carb and 35-60 for EFI. Now adjust the fuel pressure regulator to the desired setting. Test drive the vehicle to ensure proper operation and re-check the fuel system for leaks. If any leaks are found, immediately discontinue use of the vehicle and repair the leak(s) before further use!

# **Contact US**

## **Aeromotive Product Warranty, Policy and Procedure: Retail**

All Aeromotive products sold are warranted free from defects in materials and workmanship for a period of one year from the original date of purchase. No warranty claim will be valid without authentic, dated proof of purchase.

This warranty is to the original retail purchaser and none other and is available directly from Aeromotive and not through any point of distribution or purchase.

If a defect is suspected, the retail purchaser must contact Aeromotive directly to discuss the problem, possible solutions and obtain a Return Goods Authorization (RGA), if deemed necessary by the company. All returns must be shipped freight pre-paid to the company and with valid RGA before they will be processed.

Aeromotive will examine any product returned with proper authorization to determine if the failure resulted from a defect or from abuse, improper installation, misapplication or alteration. Aeromotive will then, at its sole discretion return, repair or replace the product.

**Complete Warranty Information is available at:** <https://aeromotiveinc.com/product-warranty/>

RGA NUMBER REQUIRED FOR ALL RETURNS TO AEROMOTIVE.

To obtain an RGA number, please call (913) 647-7300 and ask for the Returns and Repairs department.

- **Shipping & Returns**  
Aeromotive Inc.  
10955 Mill Creek Road  
Lenexa, KS 66219

**General Inquiries and Tech Line:** (913) 647-7300

**General Email:** [info@aeromotiveinc.com](mailto:info@aeromotiveinc.com)

**Tech Email:** [tech@aeromotiveinc.com](mailto:tech@aeromotiveinc.com)

*The Aeromotive Tech Lines are open Monday through Friday from 9:30AM to 5:00PM Central Standard Time.*



**WARNING:** This product can expose you to chemicals, including chromium, which is known to the State of California to cause cancer or birth defects or other reproductive harm. For more information, visit: [www.p65Warnings.ca.gov](http://www.p65Warnings.ca.gov)

### ***AEROMOTIVE, INC. LIMITED WARRANTY***

This Aeromotive Product, with proof of purchase dated on or after January 1, 2003, is warranted to be free from defects in materials and workmanship for a period of one year from the original date of purchase. No warranty claim will be valid without authentic, dated proof of purchase.

This warranty is to the original retail purchaser and none other and is available directly from Aeromotive and not through any point of distribution or purchase.

If a defect is suspected, the retail purchaser must contact Aeromotive directly to discuss the problem, possible solutions and obtain a Return Goods Authorization (RGA), if deemed necessary by the company. Please call 913-647-7300 and dial option 3 for the technical service dept. All returns must be shipped freight pre-paid to the company and with valid RGA before they will be processed.

Aeromotive will examine any product returned with the proper authorization to determine if the failure resulted from a defect or from abuse, improper installation, misapplication or alteration. Aeromotive will then, at it's sole discretion, return, repair or replace the product.

If any Aeromotive product is determined defective, buyer's exclusive remedy is limited in value to the sale price of the good. In no event shall Aeromotive be liable for incidental or consequential damages.

Aeromotive expressly retains the right to make changes and improvements in any product it manufactures and sells at any time. These changes and improvements may be made without notice at any time and without any obligation to change the catalogs or printed materials.

Aeromotive expressly retains the right to discontinue at any time and without notice any Aeromotive product that it manufactures or sells.

This warranty is limited and expressly limits any implied warranty to one year from the date of the original retail purchase on all Aeromotive products.

No person, party or corporate entity other than Aeromotive shall have the right to: determine whether or not this Limited Warranty is applicable to any Aeromotive product, authorize any action whatsoever under the terms and conditions of this Limited Warranty, assume any obligation or liability of any nature whatsoever on behalf of Aeromotive under the terms and conditions of this Limited Warranty.

This Limited Warranty covers only the product itself and not the cost of installation or removal.

This Limited Warranty is in lieu of and expressly excludes any and all other warranties, expressed or implied. This Limited Warranty gives you specific legal rights, and you may also have other rights which vary from state to state.