

IGNITOR[®]

ELECTRONIC IGNITION

24-Volt Negative Ground Instructions

For Part Number: 1569N24 & 2561N24

Before installing, please read the following important information....

1. **NOTE: DO NOT REMOVE BALLAST RESISTOR, IT MUST BE USED WITH A 3.0 OHM COIL.**
2. The Ignitor is designed for 24-volt negative ground systems.
3. The Ignitor is compatible only with a 3.0 ohm "resisted style" coil. You can purchase our 3.0 ohm Flamethrower coil.
4. Connect the Ignitor black wire to the negative (-) side of the coil.
5. The red wire must be connected to the 24-volt side of the ballast resistor or a 24-volt switching power source.

-
1. **PRIOR TO INSTALLATION TURN IGNITION SWITCH OFF OR DISCONNECT THE BATTERY**
 2. Remove distributor cap and rotor from distributor. Do not disconnect spark plug wires from cap. Examine cap and rotor for wear or damage. Replace as needed.
 3. Disconnect the point wire from the negative (-) side of the coil. Remove the point wire, point, and condenser.
 4. The distributor requires a minor modification. NOTE: Distributor removal may be required.
 5. File or drill the two rivets heads and remove the small bracket from the breaker plate. See figure A
 6. Clean all dirt and excess oil from the breaker plate, point cam and distributor housing.
 7. Install Ignitor plate over point pivot pin and line up hole on Ignitor plate to screw hole on breaker plate. Fasten Ignitor plate to breaker plate using the screw provided.
 8. Attach ground wire to breaker plate and distributor housing. See figure A.
 9. Mount sleeve over distributor shaft, onto point cam. Rotate the sleeve until a slight locating position is felt before applying pressure. Press down firmly insuring sleeve is fully seated.
 10. Insert wires through hole in the distributor housing and pull wire grommet into place. **CAUTION:** Care must be taken to insure wires do not interfere with moving parts.
 11. Install rotor and distributor cap. Make sure all spark plug wires are securely attached. **WARNING!!! DO NOT USE WITH SOLID CORE IGNITION WIRES.**
 12. See wiring Instructions.

LIMITED WARRANTY

Pertronix, LLC. Warrants to the original Purchaser of its solid-state ignition system (product) that the Ignitor, magnet assembly and wiring (components) shall be free from defects in material and workmanship for a period of (30) months from the date of purchase.

If within the period of the foregoing warranty Pertronix finds, after inspection, that the product or any component thereof is defective, Pertronix will, at its option, repair such products or component or replace them with identical or similar parts PROVIDED that within such period Purchaser:

1. Promptly Notifies Pertronix, in writing, of such defects.
2. Delivers the defective products product or component to Pertronix (ATTN: Warranty) with proof of purchase date; and
3. Has installed and used the product in a normal and Proper manner, consistent with Pertronix printed instructions.

THE FORGOING LIMITED WARRANTY IS EXCLUSIVE AND IN LIEU OF ALL OTHER WARRANTIES, WHETHER EXPRESSED OR IMPLIED, INCLUDING AND IMPLIED WARRANTY OR MERCHANTABILITY OR FITNESS FOR A PURPOSE.

THE FURNISHING OF A REPAIR OR REPLACEMENT COMPONENTS SHALL CONSTITUTE THE SOLE REMEDY OF PURCHASER AND THE SOLE LIABILITY OF PerTronix WHETHER ON WARRANTY, CONTRACT OR FOR NEGLIGENCE, AND IN NO EVENT WILL PerTronix BE LIABLE FOR MONEY DAMAGES WHETHER DIRECT OR CONSEQUENTIAL.



440 E. Arrow Highway
San Dimas, CA. 91773
909-599-5955 www.pertronix.com

FIGURE A
91569 & 92561
IGNITOR KIT

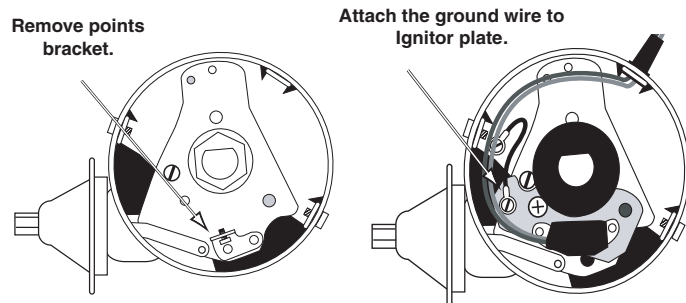

WIRING INSTRUCTIONS

1. A minimum 3.0 Ohm coil and 3.0 Ohm ballast resistor must be used with all 24-volt applications.
2. Connect the ignitor black wire to the negative (-) side of the ignition coil.
3. The red wire must be connected to the 24-volt side of the ballast resistor or a 24-volt switching power source.
4. Reconnect battery and make sure all wires are connected.
5. The engine can now be started. Let the engine run for a few minutes and then set the timing in the conventional manner.

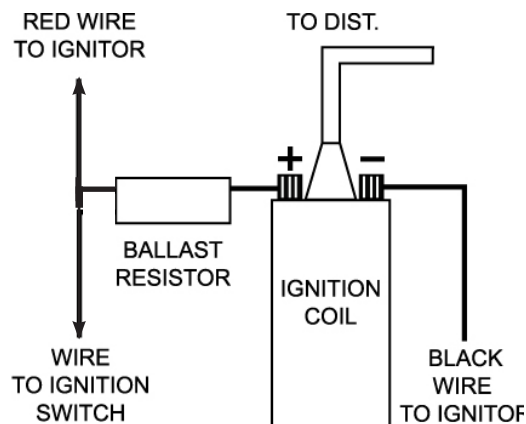

Ignitor COMMON QUESTIONS AND ANSWERS

Q. What is the first thing I should check if the engine would not start?
 A. Make certain all wires are connected securely to the proper terminals.

Q. The engine will not start or runs rough. Are there any tests I can do?
 A. Yes, remove the red ignitor wire from the ballast resistor. Connect jumper wire from the positive side of the battery to the red ignitor wire just removed from the ballast resistor. If the engine starts, then you have a low voltage problem. Remember this is just a test. Not intended for permanent installation.

Q. How can I fix a low voltage problem?
 A. Insure that the red ignitor wire is connected to the ignition wire prior to the ballast resistor.

Q. Should I remove the starter bypass wire?
 A. No, the starter bypass wire is needed to provide voltage while starting (cranking).

Q. What type of coil do I need?
 A. The ignitor is compatible only with a "points type" coil. A minimum 3.0 ohm coil and a 3.0 ohm ballast resistor must be used on all 24-volt applications.

Q. How do I check my coil for resistance?
 A. First you need an ohmmeter. Remove all the wires from the coil. Attach the ohmmeter to both the positive and negative terminals. The reading should be 3.0 Ohms or greater (Your local auto parts store can do this for you if you don't have an ohmmeter)

Q. What do I do if my coil does not have enough resistance?
 A. You may purchase and install a ballast resistor from your local auto parts store. You may also choose to purchase a 3.0 ohm Flamethrower 40,000-volt coil, which provides resistance internally.

Q. What happens if you leave the ignition switch on when the engine is not running?
 A. This can cause your coil to overheat, which may cause permanent damage to the coil and the ignitor.

Q. May I modify the length of the wires?
 A. Yes, you can cut the wires to any length your application may require. You may also add length of wire if needed (20-gauge wire). Please make sure all wire splice are clean and connections are secure.

Q. How can I get additional help?
 A. Call our tech line (909-547-9058) for any further instructions or questions.
