

# IGNITOR<sup>®</sup>

## ELECTRONIC IGNITION

### 12-Volt Negative Ground Instructions

For Part Number: 1183P12

Before installing, please read the following important information....

1. The Ignitor is designed for 12-volt Positive ground systems.
2. The Ignitor is compatible only with a "resisted style" coil. Eight cylinder engines require a minimum of 1.5 ohms of resistance. Six & four cylinder engines require a minimum of 3.0 ohms of resistance.
3. If your Ignition coil has the proper primary resistance, remove or bypass all external resistors. **Note: Do not remove resistors if the coil primary resistance is lower than specified.**
4. The black wire from the Ignitor must be connected to the ignition switch wire.
5. The black/white wire must be connected to the negative (-) side of the coil.

#### LIMITED WARRANTY

Pertronix, Inc. Warrants to the original Purchaser of its solid-state ignition system (product) that the Ignitor, magnet assembly and wiring (components) shall be free from defects in material and workmanship for a period of (30) months from the date of purchase.

If within the period of the foregoing warranty Pertronix finds, after inspection, that the product or any component thereof is defective, Pertronix will, at its option, repair such products or component or replace them with identical or similar parts PROVIDED that within such period Purchaser:

1. Promptly Notifies Pertronix, in writing, of such defects.
2. Delivers the defective products product or component to Pertronix (ATTN: Warranty) with proof of purchase date; and
3. Has installed and used the product in a normal and Proper manner, consistent with Pertronix printed instructions.

THE FORGOING LIMITED WARRANTY IS EXCLUSIVE AND IN LIEU OF ALL OTHER WARRANTIES, WHETHER EXPRESSED OR IMPLIED, INCLUDING AND IMPLIED WARRANTY OR MERCHANTABILITY OR FITNESS FOR A PURPOSE.

THE FURNISHING OF A REPAIR OR REPLACEMENT COMPONENTS SHALL CONSTITUTE THE SOLE REMEDY OF PURCHASER AND THE SOLE LIABILITY OF PerTronix WHETHER ON WARRANTY, CONTRACT OR FOR NEGLIGENCE, AND IN NO EVENT WILL PerTronix BE LIABLE FOR MONEY DAMAGES WHETHER DIRECT OR CONSEQUENTIAL.

#### PRIOR TO INSTALLATION TURN IGNITION SWITCH OFF OR DISCONNECT THE BATTERY

1. Remove distributor cap and rotor from distributor. Do not disconnect the spark plug wires from cap. Examine parts for excessive wear. Replace as needed
2. Remove the point wire from the negative coil terminal.
3. Remove and retain the points and condenser. Installing the Ignitor does not alter the internal configuration of your distributor. Therefore, the points, condenser and hardware can be used as backup.
4. Clean all dirt and excess oil from the breaker plate and point cam.
5. Adapter Plate Installation:
  - **Single Point Distributors:**
    - Install the Ignitor lower adapter plate over the stud (point pivot pin) and over the eccentric screw (point adjustment screw), rotate eccentric screw if necessary to properly align adapter plate to screw hole on breaker plate, for clockwise distributors see **figure A**. For Counter Clockwise distributors see **figure B**.
  - **Dual Point Distributors:**
    - Clockwise distributors see **figure B**.
    - Counter Clockwise distributors see **figure A**.
  - Use the provided screw to hold the plate in place.
6. Install the Ignitor module onto the adapter plate. Use the provided screws to hold the module in place. Do not over tighten.
7. Feed the two terminal ends of the wire through the hole in the distributor housing. Pull the grommet into place.

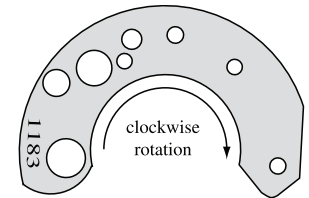

FIGURE A

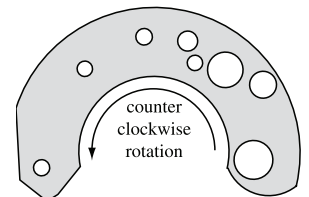

FIGURE B



440 E. Arrow Highway, San Dimas, CA. 91773

909-599-5955 [www.pertronix.com](http://www.pertronix.com)

8. Adjust the wire length inside the distributor so that it does not interfere with moving parts.
9. Place the magnet sleeve over the distributor shaft, and onto point cam. Press down firmly to insure magnet sleeve is fully seated.

**Figure C**

Distributor shafts with raised step above point cam require that spacer ring to be installed with the step portion of the spacer ring facing up.

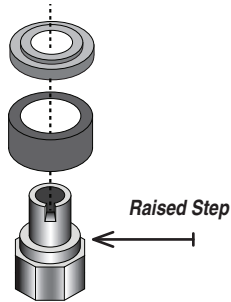

**Figure D**

Distributor shafts without a raised step above point cam require that spacer ring to be installed with the step portion of the spacer ring facing down.

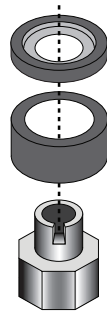

### WIRING INSTRUCTIONS

1. **NOTE: A BALLAST RESISTOR OR RESISTOR WIRE MAY OR MAY NOT BE INCLUDED IN THE ORIGINAL EQUIPMENT.**
2. Remove the ignition switch wire from the negative coil terminal. Connect the black Ignitor wire directly to the ignition switch wire.
3. Connect the Ignitor black/white wire to negative (-) side of the ignition coil.
4. Connect an insulated, AWG 20 copper stranded wire from the positive coil terminal to the positive battery or chassis.
5. The black/white Ignitor wire and the AWG 20 copper wire should be the only wires connected to the coil.
6. Make sure all wires are connected correctly, and reconnect battery.
7. The engine can now be started. Let the engine run for a few minutes and then set the timing in the conventional manner.

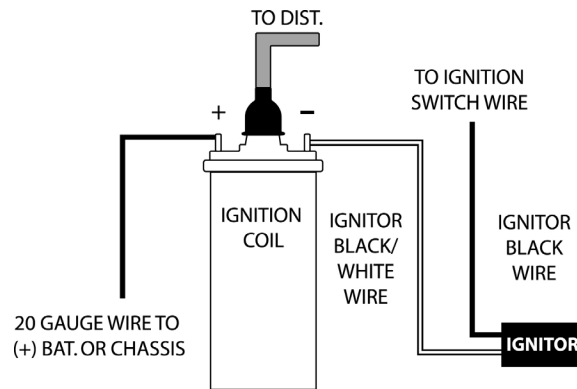

**Figure 1**

10. Look at figure **C & D** to determine the proper installation for the spacer ring.
11. Reinstall the rotor, and the distributor cap. Make sure all spark plug wires are securely attached.

### Ignitor COMMON QUESTIONS AND ANSWERS

Q. What is the first thing I should check if the engine would not start?

A. Make certain all wires are connected securely to the proper terminals.

Q. The engine will not start or runs rough. Are there any tests I can do?

A. Yes, remove the black wire from the ignition switch wire. Connect jumper wire from the negative (-) side of battery to the Ignitor black wire. If the engine starts and runs well, you may have high resistance thru your Ignition switch. This is just a test. Not intended for permanent installation.

Q. How can I fix a high resistance problem?

A. High resistance can be caused by an external ballast resistor, resistance wire or in some cases a resisted ignition switch. If the proper coil is used, remove or bypass all external resistors.

Q. Should I remove the starter bypass wire?

A. No, the starter bypass wire is needed to provide voltage while starting (cranking).

Q. What type of coil do I need?

A. The ignitor is compatible only with a "points type" coil. Eight cylinder engines require a minimum of 1.5 Ohms of resistance in the primary circuit. Four & six cylinder engines require a minimum of 3.0 Ohms of resistance (primary).

Q. How do I check my coil for resistance?

A. First you need an ohmmeter. Remove all the wires from the coil. Attach the ohmmeter to both the positive and negative terminals. The reading should be 1.5 Ohms or greater for eight cylinder engines and 3.0 Ohms or greater for four & six cylinder engines. (Your local auto parts store can do this for you if you don't have an ohmmeter)

Q. What do I do if my coil does not have enough resistance?

A. You may purchase and install a ballast resistor from your local auto parts store. You may also choose to purchase a Flamethrower 40,000-volt coil, which provides resistance internally. Note: Many vehicles come with resistor wire or a ballast resistor. These applications do not need an additional resistor.

Q. What happens if you leave the ignition switch on when the engine is not running?

A. This can cause your coil to overheat, which may cause permanent damage to the coil and the ignitor.

Q. May I modify the length of the wires?

A. Yes, you can cut the wires to any length your application may require. You may also add length of wire if needed (20-gauge wire). Please make sure all wire splice are clean and connections are secure.

Q. How can I get additional help?

A. Call our tech line (909-599-5955) for any further instructions or questions.