



## Modular Holley LT4/LT5 Accessory Drive Kits

PICTURE	Pages	DESCRIPTION	P/N	APPLICATION
	All	<b>Comprehensive Drive Kits</b>	<b>20-220</b> <b>20-220BK</b>	<b>LT4</b> <b>Wet Sump</b>
			<b>20-221</b> <b>20-221BK</b>	<b>LT4</b> <b>Dry Sump</b>
			<b>20-230</b> <b>20-230BK</b>	<b>LT5</b> <b>Dry Sump</b>
	8 & 15-19	<b>Add-On Power Steering Kits</b> Works with original equipment GM accessories and brackets.	<b>20-222</b> <b>20-222BK</b>	<b>LT4</b> <b>Wet Sump</b>
			<b>20-223</b> <b>20-223BK</b>	<b>LT4</b> <b>Dry Sump</b>
			<b>20-233</b> <b>20-233BK</b>	<b>LT5</b> <b>Dry Sump</b>
	9	<b>Alternator / Bracket Kits</b> Offers notably more application clearance at the alternator while working with original equipment GM accessories and brackets and Holley add-on P/S.	<b>20-224</b> <b>20-226</b>	<b>LT4</b> <b>Wet Sump</b>
	8 & 20-24	<b>Accessories</b>	<b>97-206</b> <b>97-207</b> <b>97-210</b> <b>97-211</b> <b>97-212</b>	<b>97-185</b> <b>97-187</b> <b>717-15</b> <b>717-16</b>

Holley's complete accessory systems for LT4 and LT5 applications have all accessories pulled up and in tight. In addition, they add the much needed hydraulic power steering solution. There are no shortcuts here. Holley incorporates a splined dual bearing system that eliminates all belt stresses on the P/S pump's internal bearings, assuring long life. The supercharger drive maintains the original and optimized belt path and tensioner. The accessory layout is as if the original manufacturer had designed it for your swap application. Included with each drive system is a throttle body angle correcting adapter that better positions the throttle body for swap applications as opposed to the aggressive angle intended for the original application. Versions of these accessory drives are available for both wet and dry sump applications.

### **Features:**

- Adds power steering without any belt load on the P/S pump
- Notably more clearance to swap applications than other options
- Original equipment look
- LT4 style premium alternator
- LT4 style water pump design
- Compact SD7 A/C compressor
- A/C line adapters included
- Type II power steering pump
- P/S hard line adapters included
- Bottom outlet swivel heater hose options for swap application clearance
- Throttle body angle correcting adapter for easier intake tube routing on swap applications
- OE pulley ratios for optimal accessory performance, allows for larger SC crank pulley
- Available LT4/5 dry-sump & LT4 wet-sump applications
- LT4/5 specific accessories available for plumbing oil cooler and PCV oil separator OE systems
- Modular designs work with the original GM accessory drives:
  - Add-on power steering to the OE GM accessory drive
  - Alternator/bracket kit allows for greatly increased clearance over the OE GM alternative.
  - Combine both the above with the Holley water pump/AC compressor solution for the ultimate drive setup.

**Design Benefits Explained:**



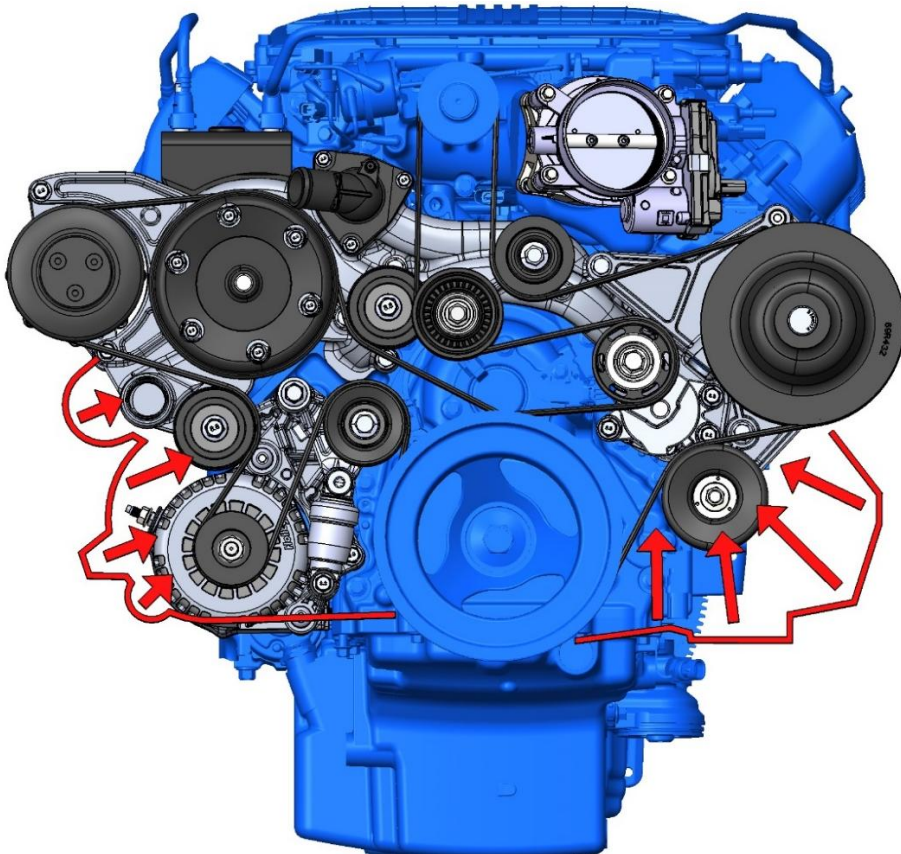
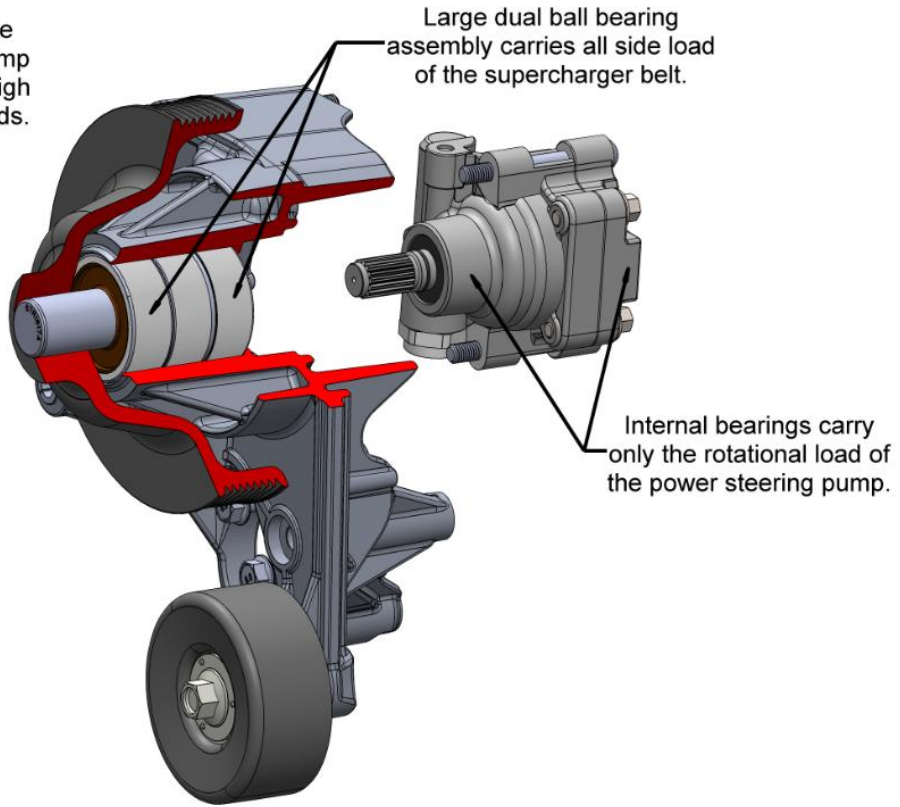





Splined bearing drive system eliminates pump bearing failure from high supercharger belt loads.

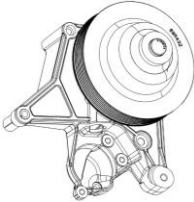

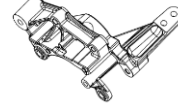







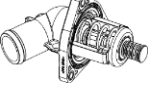
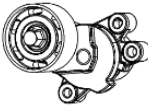
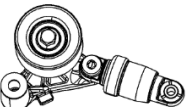



Not only does the Holley's accessory drive add a reliable power steering solution, it also pulls in accessories tighter than other drives allowing clearance for steering boxes, suspension, and frame rails in swap applications.

(GM wet-sump accessory drive and water pump silhouette shown in red).

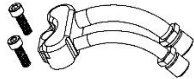
**Replacement Parts List (not all the below will be included with your system):**

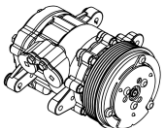
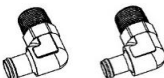
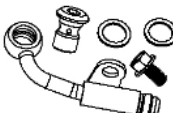
PICTURE	DESCRIPTION	REPLACEMENT MANUFACTURER & P/N
	<p>Power Steering Bracket Assembly</p>	<p>97-252 (Natural - LT4 All Except Below), 97-252BK (Black - LT4 All Except Below)</p> <p>97-253 (Natural - LT4 for Add-On P/S to Dry Sump ONLY), 97-253BK (Black - LT4 for Add-On P/S to Dry Sump ONLY)</p> <p>97-334 (Natural - LT5 All Except Below), 97-334BK (Black - LT5 All Except Below)</p> <p>97-267 (Natural LT5 for Add-On P/S to Dry Sump ONLY), 97-267BK (Black LT5 for Add-On P/S to Dry Sump ONLY)</p>
	<p>Manifold Assembly, Water Pump</p>	<p>97-250 (Natural Wet Sump), 97-250BK (Black Wet Sump)</p> <p>97-251(Natural Dry Sump), 97-251BK (Black Dry Sump)</p>
	<p>Alternator Bracket</p>	<p>Holley 97-254</p>
	<p>Alternator Bracket Spacer</p>	<p>Holley 97-255 (Wet Sump)</p>
	<p>Spacer, P/S Bracket Assembly</p>	<p>97-262 (Natural Wet Sump), 97-262BK (Black Wet Sump)</p>
	<p>Gaskets, Water Pump</p>	<p>GM 12657430</p>
	<p>Water Pump Drive Assembly -Clockwise Rotation- (not included with wet sump applications)</p>	<p>Holley 97-245</p>
	<p>Water Pump Assembly Gasket</p>	<p>GM 12619770</p>

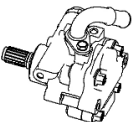
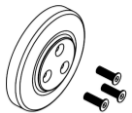
PICTURE	DESCRIPTION	REPLACEMENT MANUFACTURER & P/N
	Belt (6-Rib), Accessories	Bando 6PK1780 (20-220, 20-221, 20-230 & BK versions) Bando 6PK1500 (20-224 & 20-224)
	Belt (8-Rib), Supercharger	Gates FleetRunner® K080820HD (20-220, 20-221, 20-222 & BK ver.) Bando 8PK2130 (20-223 & BK ver.)
	Belt (11-Rib), Supercharger	Bando 11PK2185 (20-233 & BK ver.)
		Bando Aramid 11PK2137A (20-230 & BK ver.)
	Thermostat 190° & Housing	Holley 97-247 / GM 12674634
	Supercharger Tensioner	LT4 - Holley 97-243 / GM 12663624 LT5 - Holley 97-268
	Accessory Tensioner	Holley 97-244 / GM 12686229
	Supercharger Smooth Idler, Lower	LT4 - Holley 97-242 / GM 12642706 LT5 - Holley 97-269 / GM 12665035
	Supercharger Smooth Idler, Center	LT4 - Holley 97-241 / GM 12665845 LT5 - Holley 97-266
	Supercharger Ribbed Idler, Center	LT4 - Holley 97-240 / GM 12678295 LT5 - Holley 97-265
	Accessories Smooth Idler	Holley 97-249 / Gates 36101
	Alternator Harness Pigtail	Holley 197-400
	Alternator	Holley 197-302 (Natural) / 197-303 (Black)

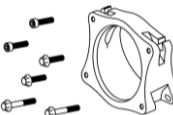
PICTURE	DESCRIPTION	REPLACEMENT MANUFACTURER & P/N
	Adapter Manifold for A/C Compressor & Hardware (Long Option)	Holley 199-201 / 199-201BK
	Adapter Manifold for A/C Compressor & Hardware (Short Option)	Holley 199-202
	SD7 A/C Compressor	Holley P/N 199-102 (Natural) / 199-104 (Black)
	Swivel 90° 3/4" Barb 3/4" NPT / Swivel 90° 5/8" Barb to 3/4" NPT	Earl's SS988412ERL / Earl's SS988409ERL
	P/S Pressure Hardline to -6 AN, Banjo Bolt, Crush Washers (2), & Hardware	Holley 198-201
	P/S Return Hardline & Hardware	Holley 198-204
	P/S Pump with Splined Shaft	Holley P/N 198-103 / GM 15857665
	A/C Compressor Pulley Cover & Hardware	Holley 97-185 (BK – Black kits only)
	Block Off, Water Pump Barb to OE Oil cooler, Female 16mm Quick Connect	Holley 97-209 (Add-On P/S to Wet Sump ONLY)
	Throttle Body Angle Adapter & Hardware	LT4 - Holley 717-15 LT5 - Holley 717-16

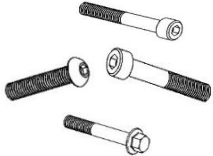
HARDWARE	REPLACEMENT KIT NUMBER	HARDWARE KIT APPLICATION
	97-256	Water Pump & A/C (Wet Sump)
	97-257	Water Pump & A/C (Dry Sump)
	97-258	P/S (Wet Sump)
	97-259	P/S (Dry Sump)
	97-260	Alternator (Wet Sump)
	97-261	Alternator (Dry Sump)

**Dimensions:**

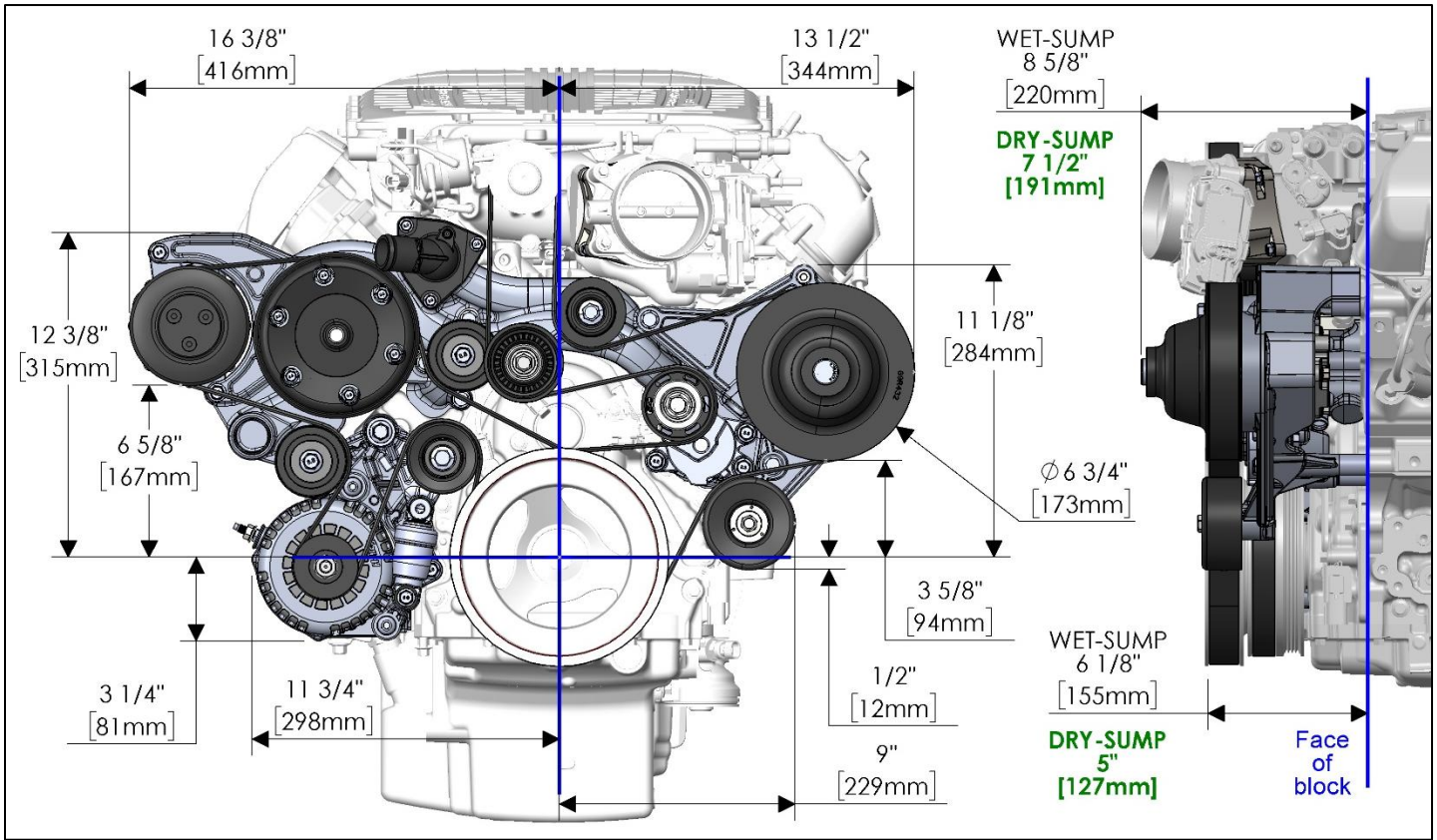

**IMPORTANT NOTE IF PAINTING COMPONENTS:** The alternator and A/C compressor ground through the bracketing. If painting or coating the alternator bracket or water pump manifold, the mating surfaces must all be bare metal allowing a ground path from the accessories' mounting feet to the engine block and ultimately the negative terminal on the battery.

## Assembly Instructions

### **Disassembly of Original Parts:**

Remove bracket from engine and harness. This bracket will not be used further.

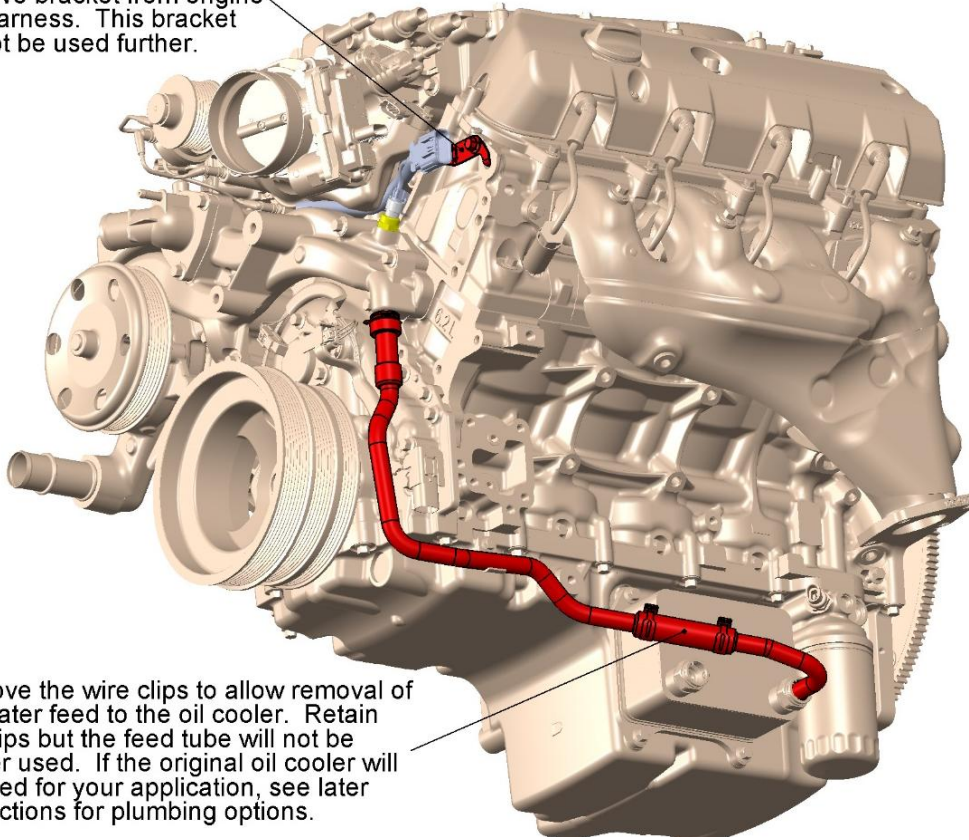

Remove the wire clips to allow removal of the water feed to the oil cooler. Retain the clips but the feed tube will not be further used. If the original oil cooler will be used for your application, see later instructions for plumbing options.

**(wet sump only)**

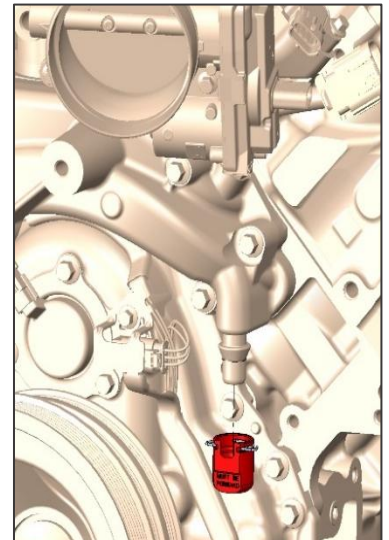

If **ONLY** installing the Holley ADD-ON power steering to wet sump applications, install the supplied red cap to the water pump barb. After installation, rotate the cap until the text is forward. See APPENDIX for alternate oil cooler plumbing.

### **If installing Holley water pump (wet and dry applications)**

**If installing Holley's A/C compressor solution:**

Remove factory PCV air/oil separator tank (wet-sump applications only)

Remove the factory water pump assembly. Retain for later use.

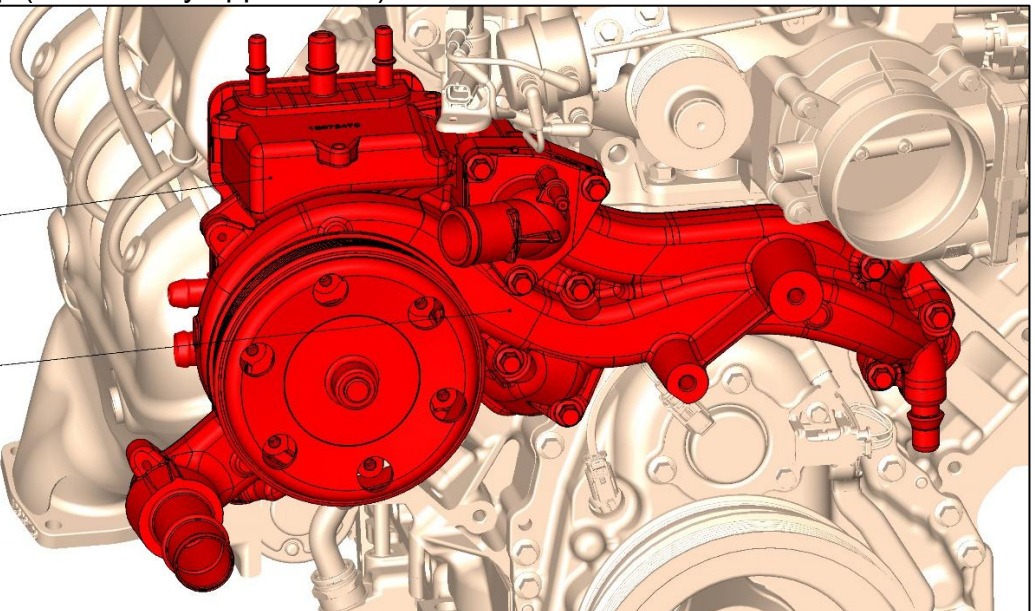

**Alternator and Bracket Assembly Installation (not included with all kits):**

HARDWARE KIT NUMBER	ENGINE APPLICATION
97-260	Wet Sump
97-261	Dry Sump

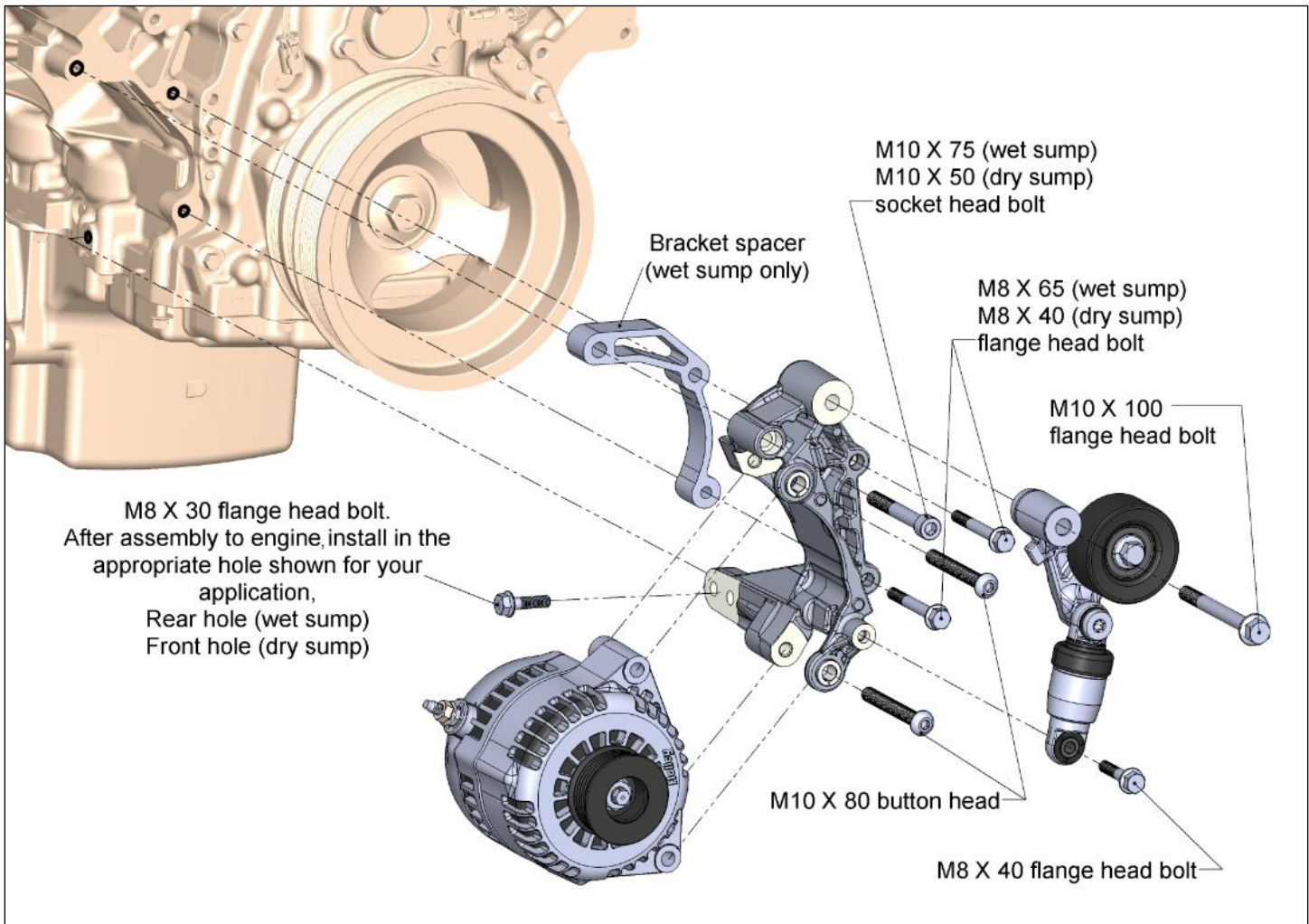

**NOTE:** Torque M8 bolts to 18 ft./lbs. Torque M10 bolts to 36 ft./lbs.

**ALTERNATOR WIRING:** See instructions included with the alternator for wiring directions.

**HELPFUL HINT:** The rear alternator housing can be rotated relative to the front housings. If desired, this will allow the charge wire and harness plug to be rotated or away from possible interferences.

Contact an alternator repair shop for "re-clocking" procedures.

## Water Pump Manifold / Bracket Pre-Assembly (not included with all kits):

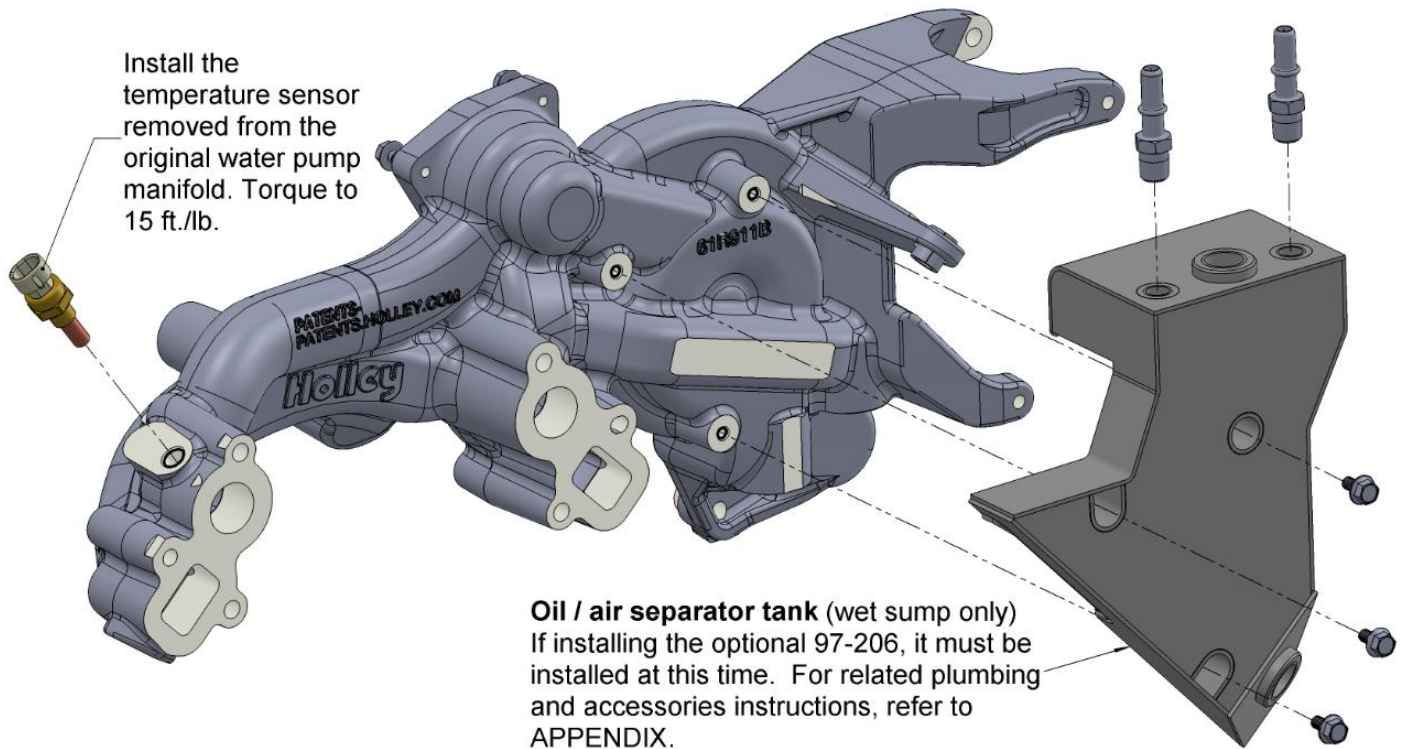

## Heater Hose Adapter Installation:

**WARNING:** Do not plug all heater passages. For safe LT engine start up cooling this path must stay open. If not utilizing a heater core, install a jumper hose between the two barbs.

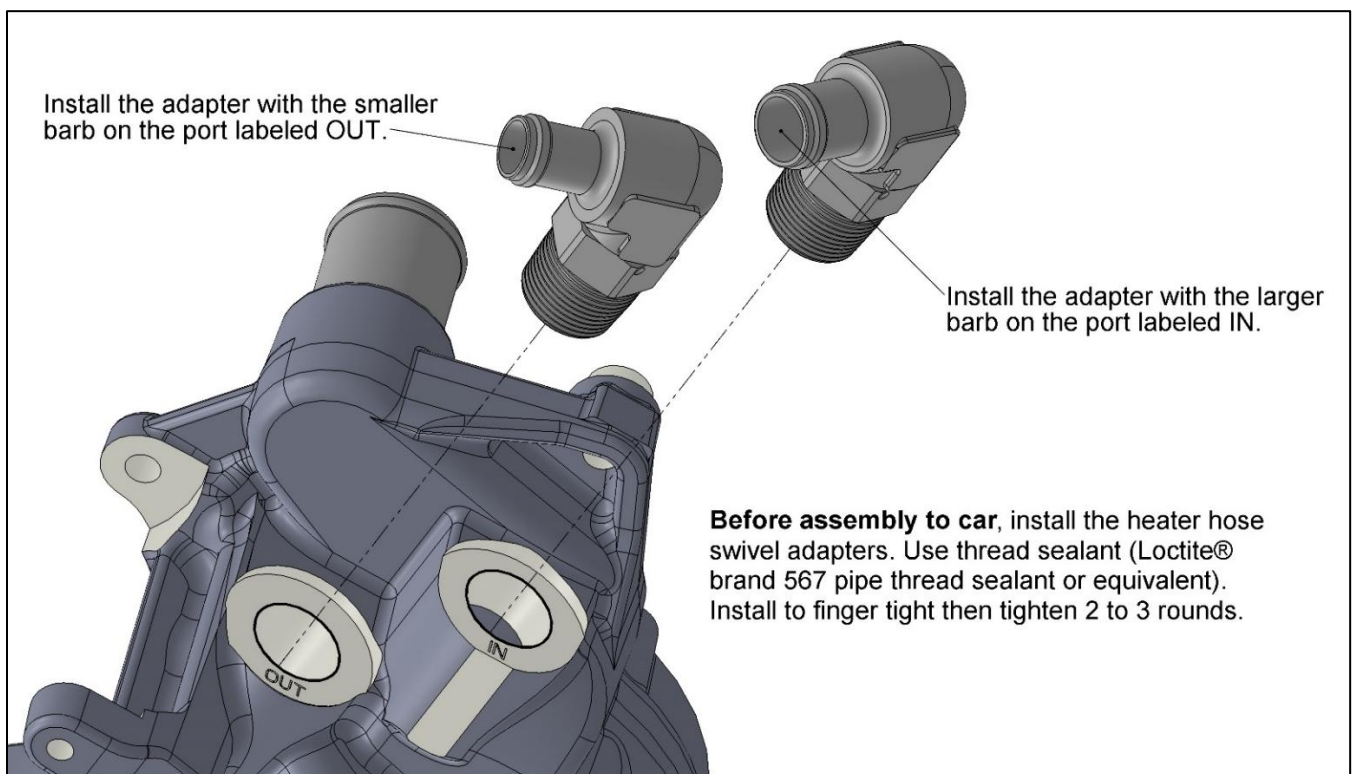

**HELPFUL HINT:** The below assembly order is optimized for explanation and the average application. For your application, determine if it is easier to assemble before or after the water pump manifold is mounted to the engine. Keep in mind adding components before mounting increases overall size and weight and will require an additional person when mounting to the engine. Torqueing of the component's bolts may be easier after mounting.

**Water Pump, Gasket, and Thermostat Assembly Installation:**

HARDWARE KIT NUMBER	ENGINE APPLICATION
97-256	Wet Sump
97-257	Dry Sump

**NOTES:**

**Wet Sump Applications** – The water pump/pulley assembly is not included. The original engine has the correct pump, which can be reused. If a new water pump is preferred, Holley P/N 97-245 can be purchased.

**Dry Sump Applications** – Use the provided pump assembly P/N 97-245. **Do Not use the original dry sump water pump assembly. The original pump is the wrong rotation direction for the Holley accessory drive. Using the incorrect pump will decrease cooling and may damage the engine.**

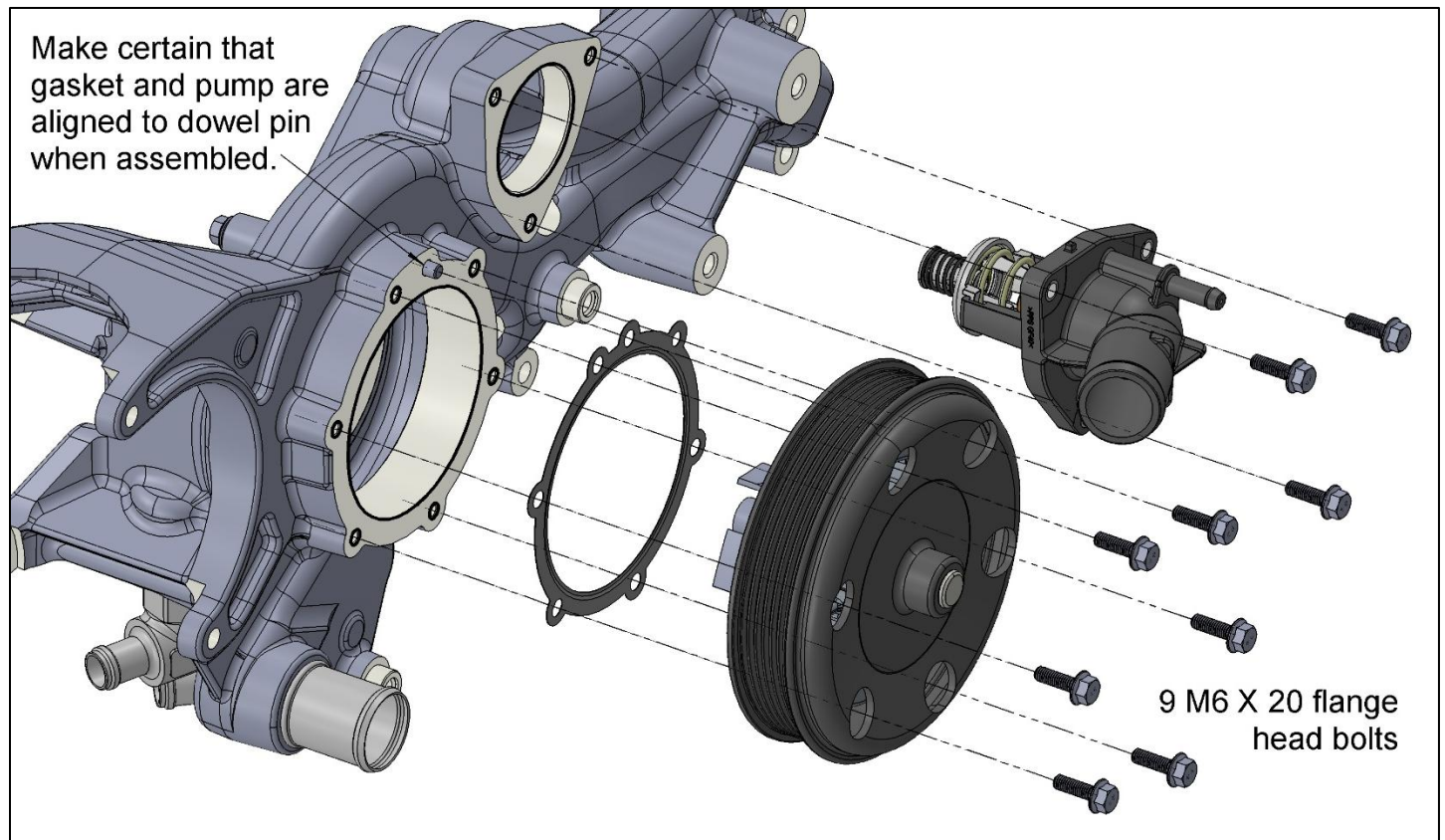

**NOTE:** Torque M6 button head bolts to 85 in./lbs.

## Water Pump Assembly to Block Installation:

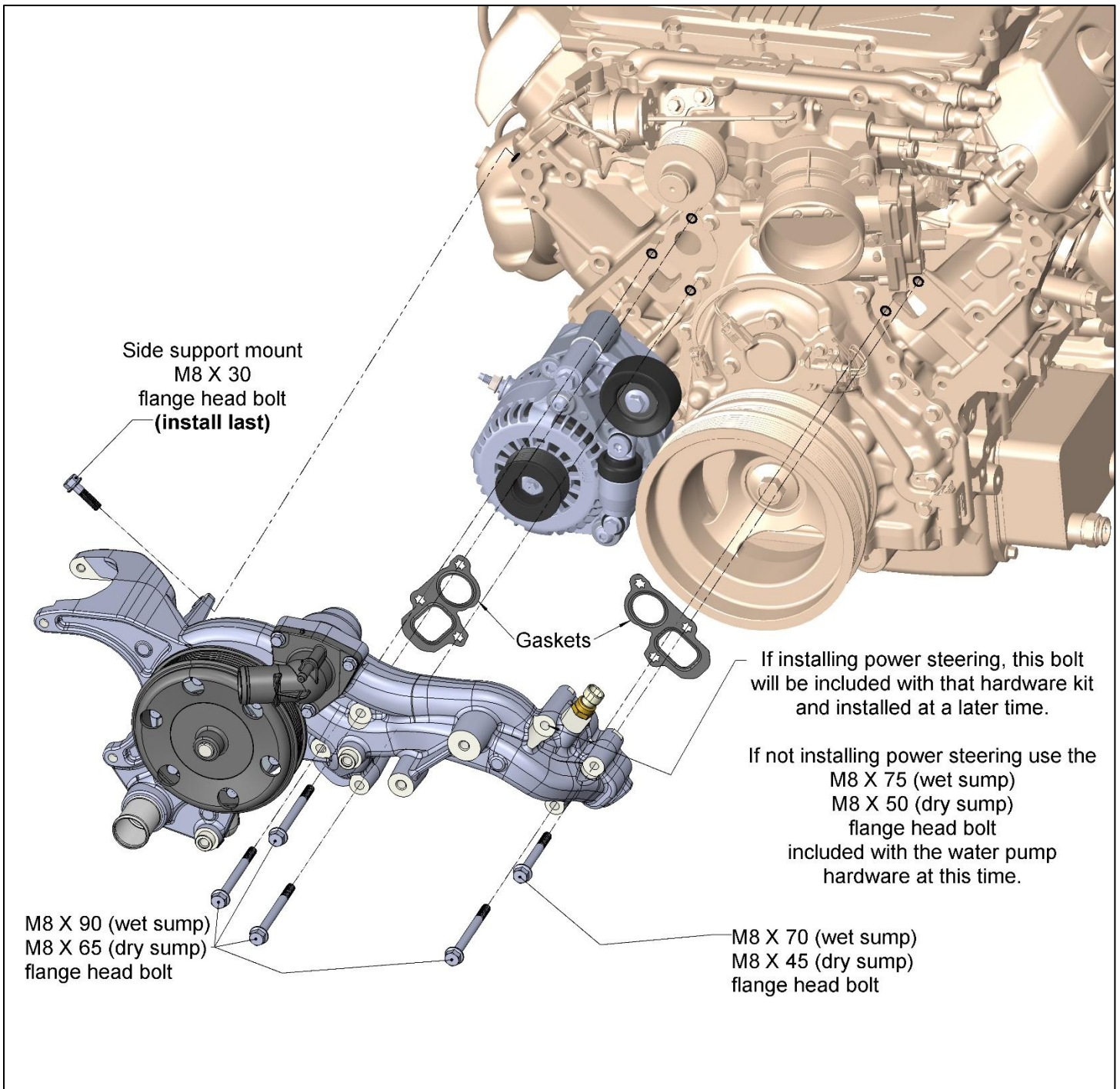

**NOTE:** Torque M8 bolts to 18 ft./lbs.

**Pulley Installation:**

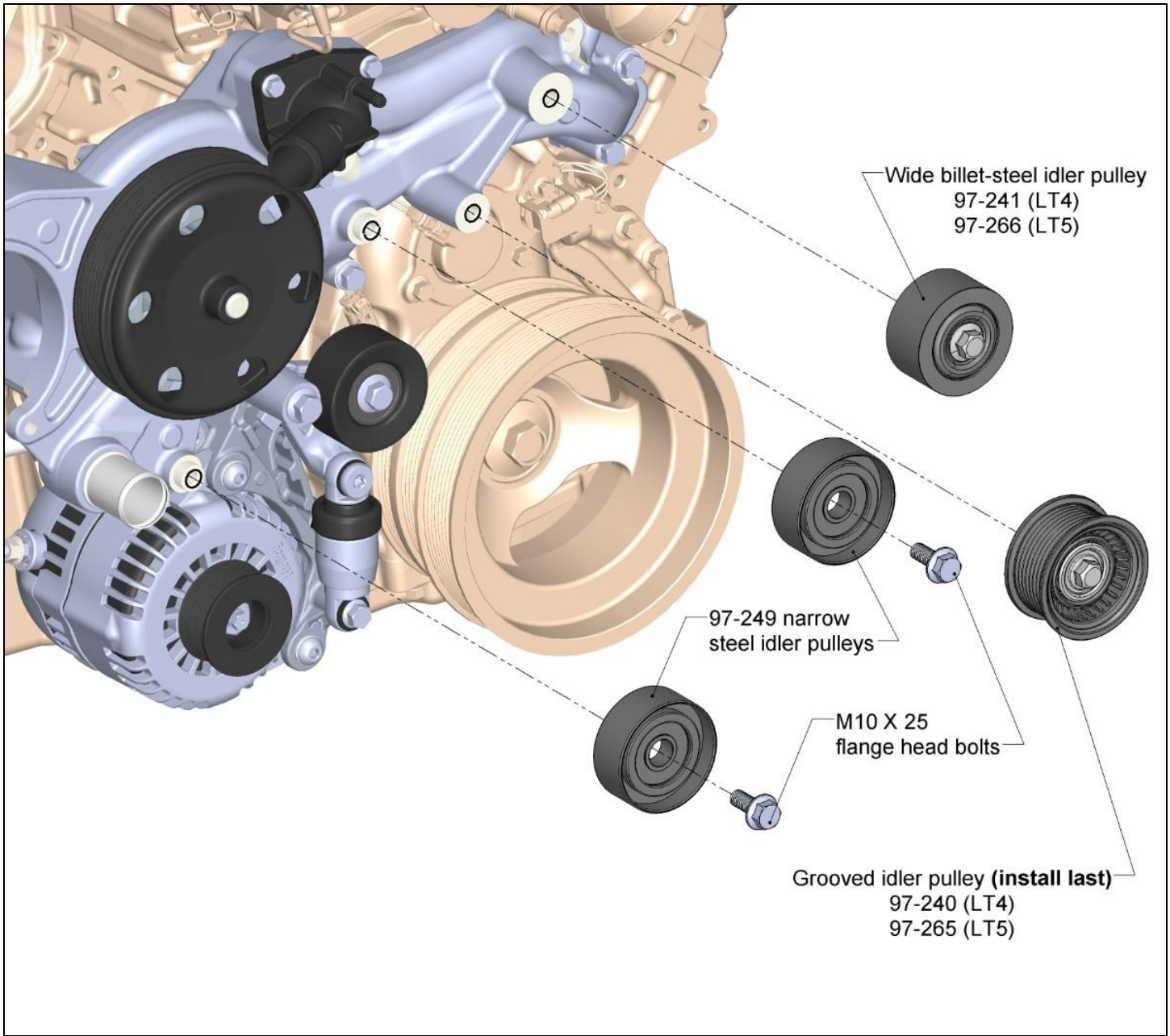

**NOTE:** Torque M10 bolts to 36 ft./lbs.

## A/C Compressor Installation:

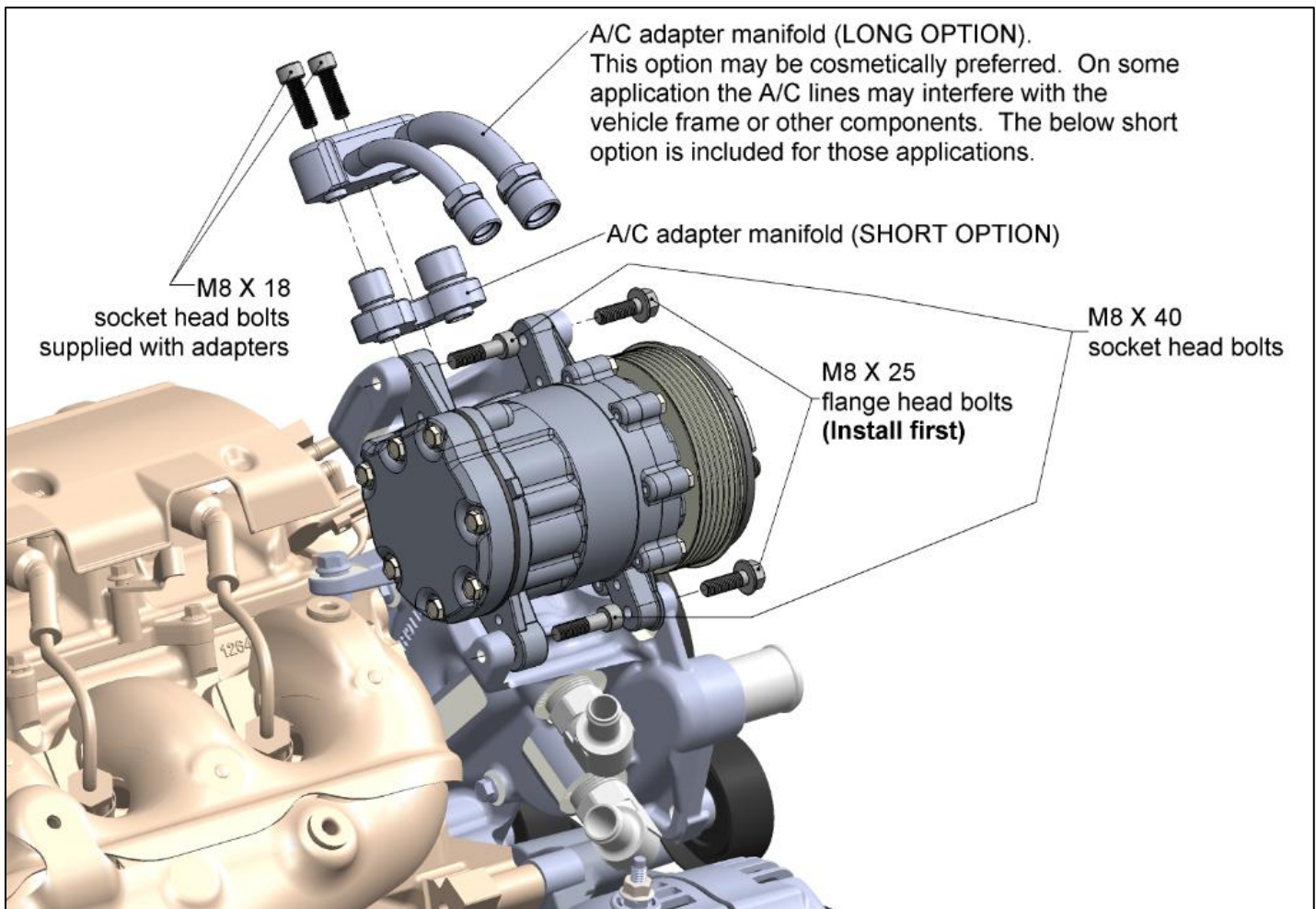
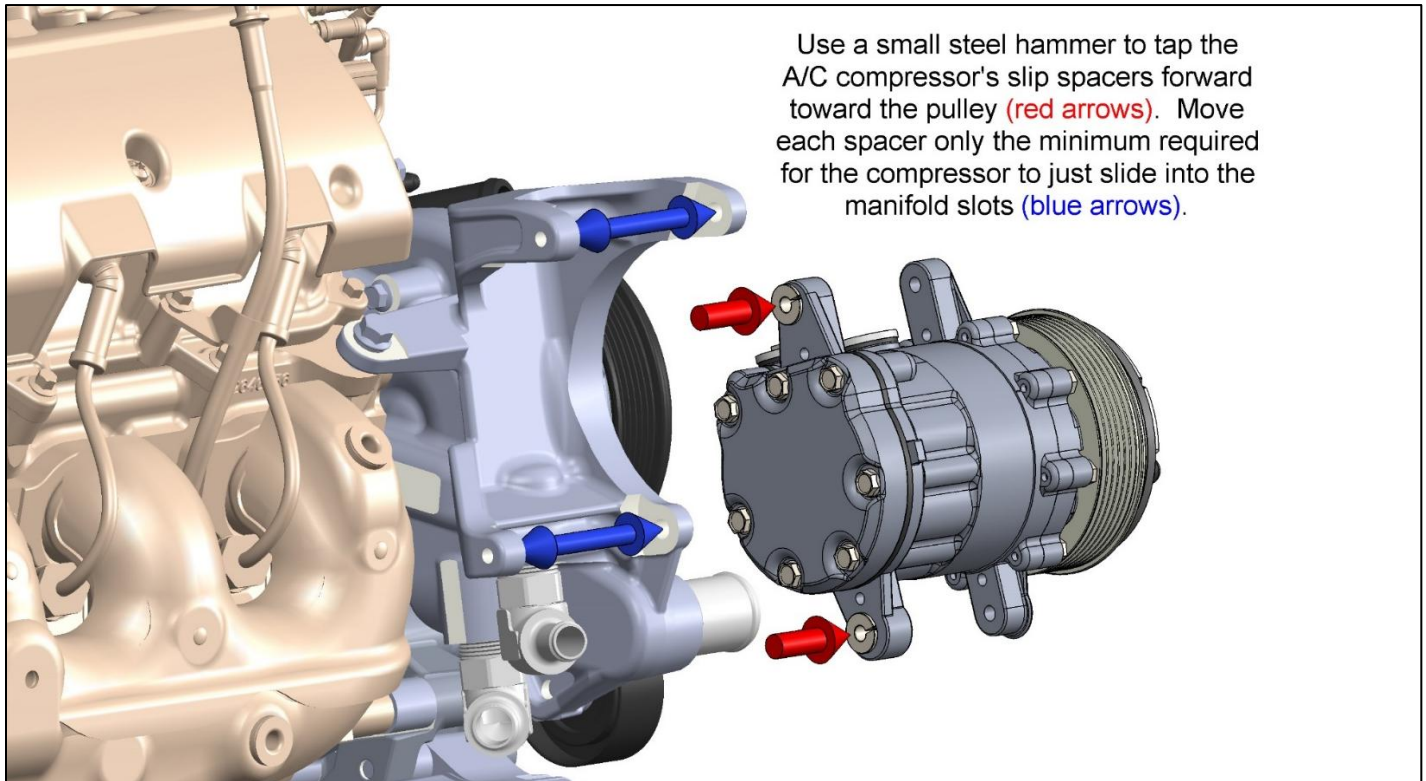

**NOTE:** Torque M8 bolts to 18 ft./lbs.

**P/S Pump Assembly (not included with all kits):**

Remove the supply tube the power steering pump is shipped with and discard.

Retain the bolt and O-ring for later use.

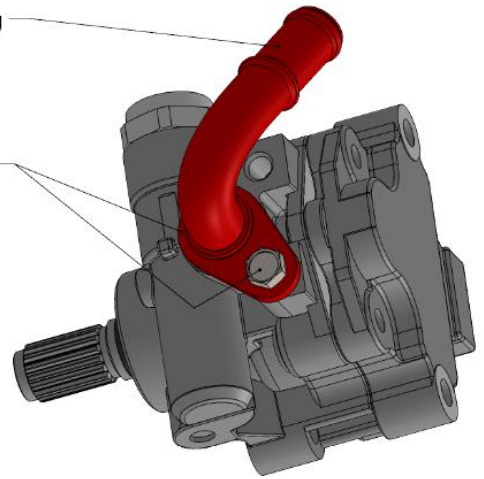

Sealing crush washers both sides

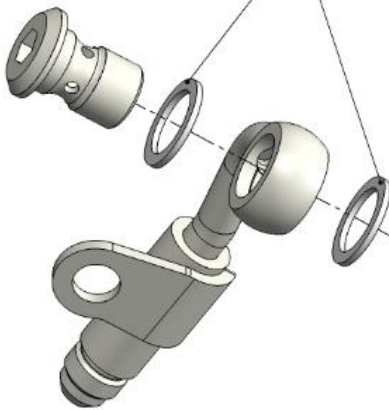

Bolt from previously removed tube.

Use the original tube O-ring if not damaged. A replacement O-ring is supplied if needed.

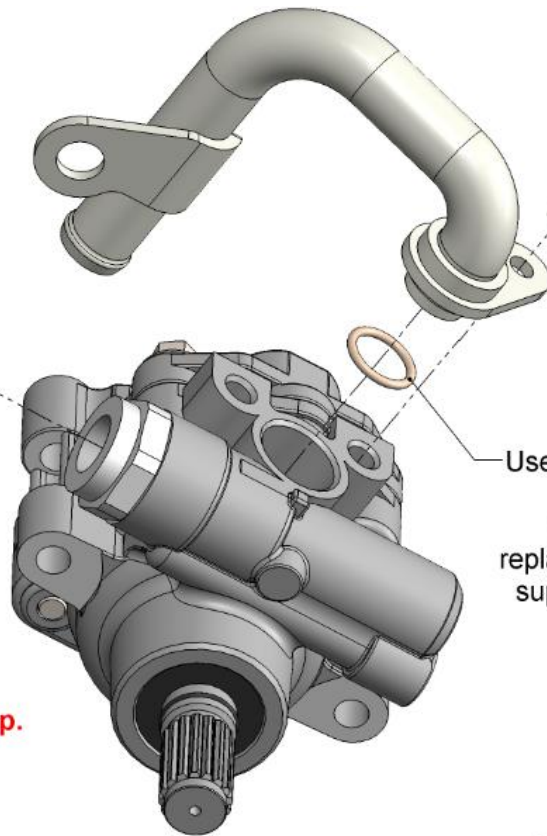

**Hand tighten only at this step.**

Approximate tube orientation after assembled.

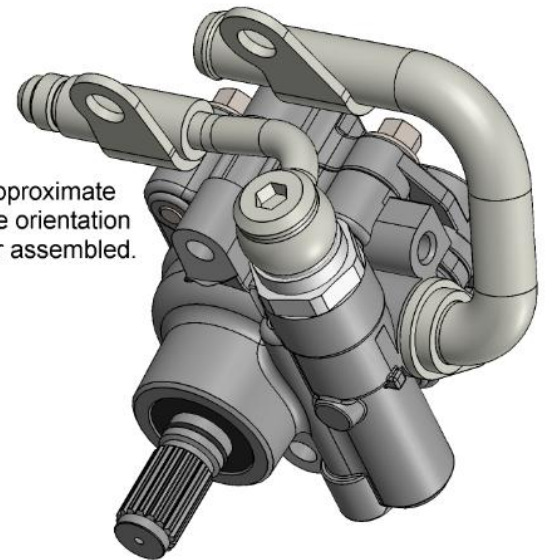

## P/S Bracket Assembly:

**FIRST:** Install the two M8 X 70 button head bolts.

**IMPORTANT:** Install these bolts in an even manner while holding the pump square to the bracket pads. Torque to 18 ft./lbs. alternating between each bolt. Once torqued, the pulley should turn free by hand. If the pulley does not turn free, repeat the torquing process. It is acceptable if the pulley has a tight spot when rotated as long as it can be fully rotated by hand.

**THIRD:** Torque M6 bolt to 85 in./lbs.

**LAST:** Torque banjo bolt to 25 ft./lbs. through access hole in bracket.

**SECOND:** Install two M8 X 16 serrated flange head bolts supplied with line adapters. Torque M8 bolts to 18 ft./lbs.

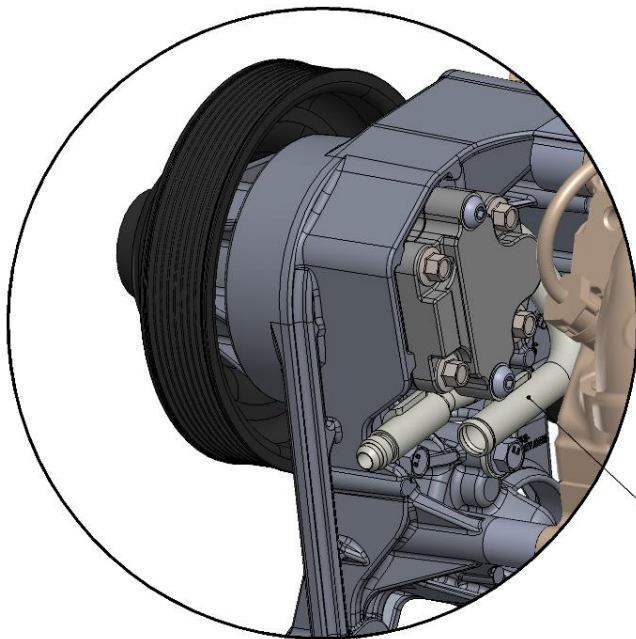
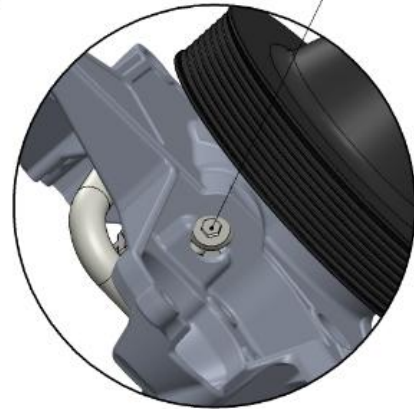

**NOTE:** It may be desirable to install the pump feed hose before installing the bracket assembly to the engine. Access to the tube may be difficult after assembly **especially** on dry sump applications.

**P/S Bracket Assembly Installation:**

HARDWARE KIT NUMBER	ENGINE APPLICATION
97-258	Wet Sump
97-259	Dry Sump

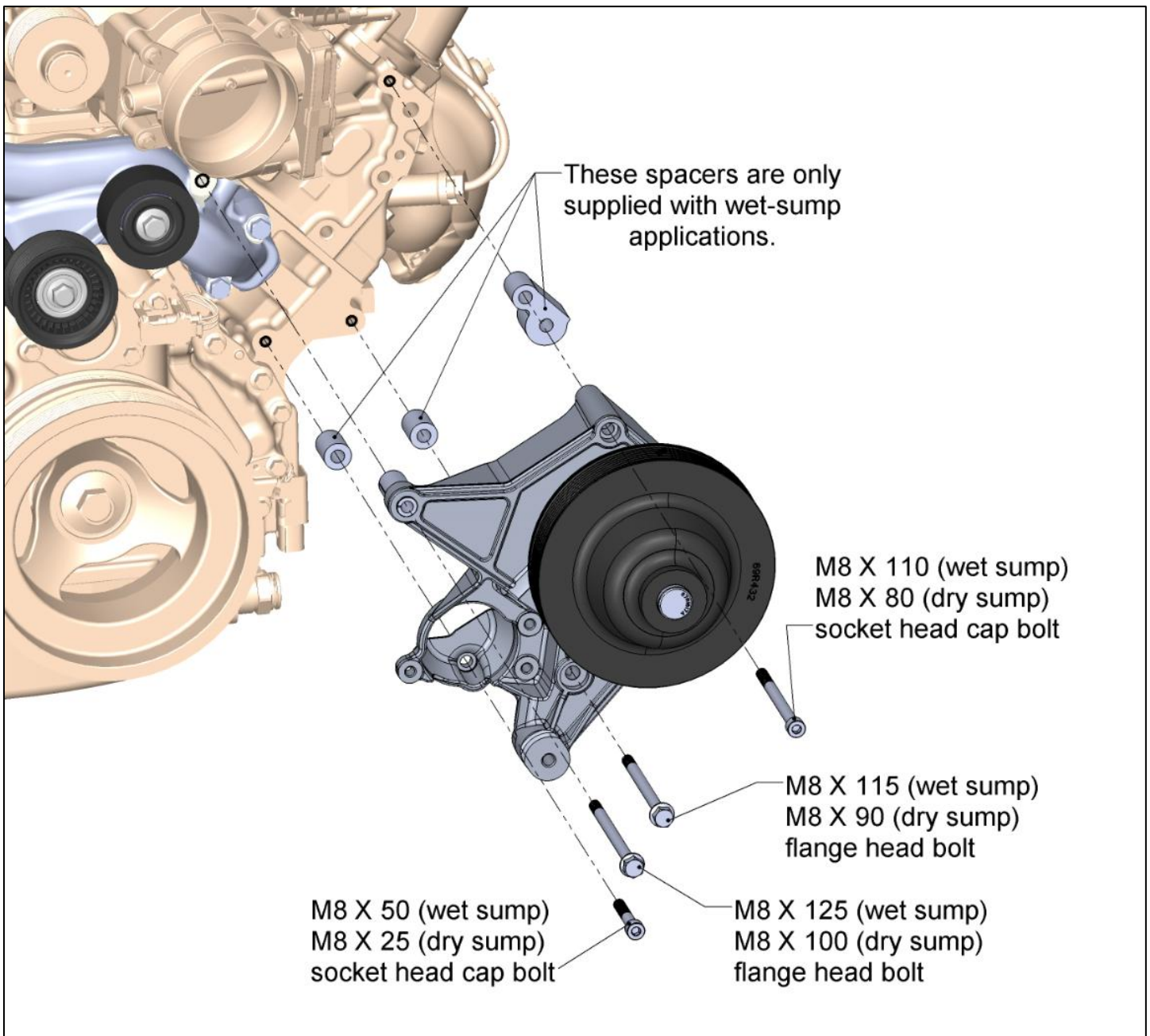

**NOTE:** Torque M8 bolts to 18 ft./lbs.

### **SC Tensioner and Idler Installation:**

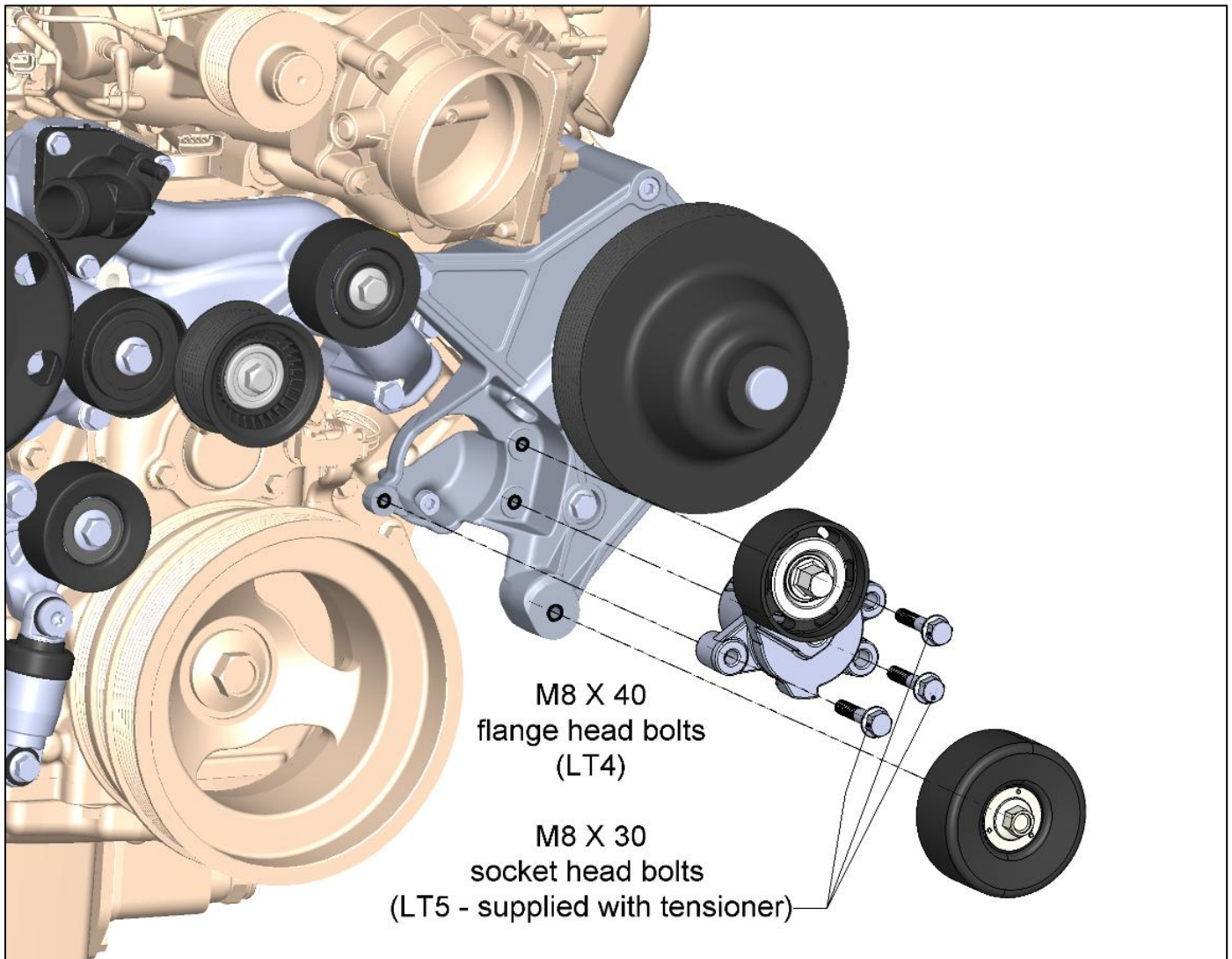

**NOTE:** Torque M8 bolts to 18 ft./lbs. Torque M10 bolts to 36 ft./lbs.

### **PS Pump Reservoir Options:**

The best shape and mounting location for the P/S pump reservoir varies for each swap application. Often it is better esthetically to mount the reservoir to the fender or wheel well than to the engine. There are several reservoirs available from Holley and other aftermarket suppliers. One good option is GM P/N 15285644. This reservoir is well matched to the supplied P/S pump and has substantial baffling. This reservoir will likely require custom mounting for your application.



**Belt Installations:**

**NOTE:** If installing the alternator/bracket only kit, follow the OE accessory drive belt routing instead of the below.

**FIRST:** Install the accessory belt as shown below.

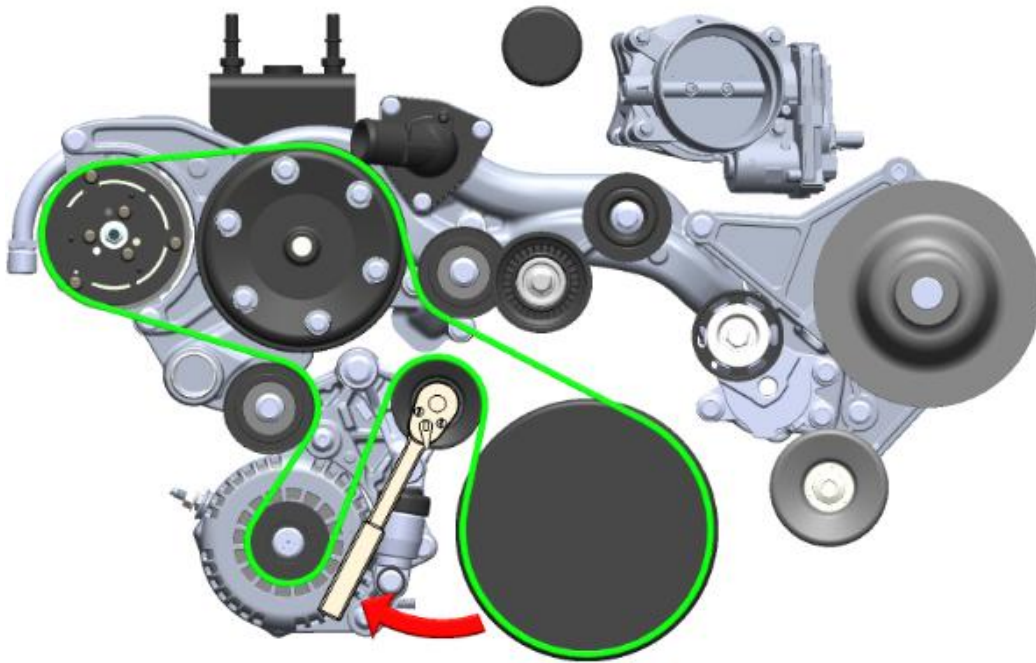





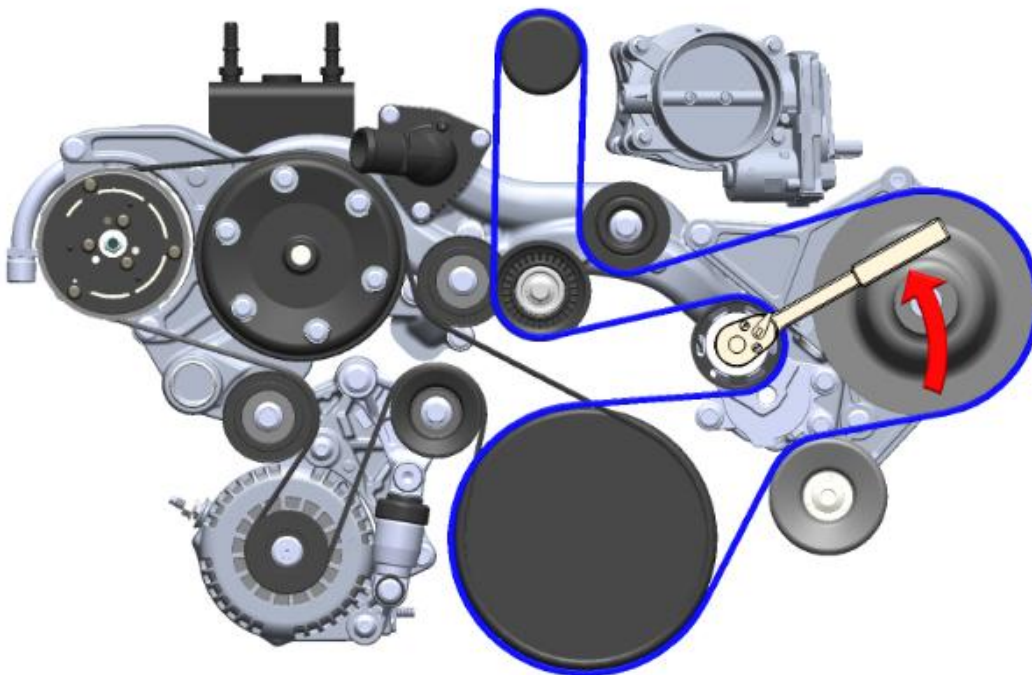







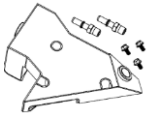

**NOTE:** For easy belt installation, route onto all pulleys leaving one smooth idler pulley for last. It is best if this last smooth pulley is not the tensioner pulley.

**SECOND:** Install the supercharger belt as shown below

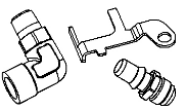
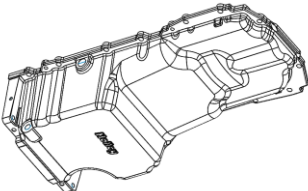

**APPENDIX (optional accessories)**

PICTURE	Ref. #	DESCRIPTION	P/N
	1	Block Coolant Adapter for Oil Cooler (28mm X 1.25 male to -10 AN male)	Holley 97-210
	2	-10 AN Twist-On (Dynamic Swivel) 90 Degree Bent Tube Hose-End	Holley AT809110ERL
	3	-10 AN Twist-On (Dynamic Swivel) 120 Degree Bent Tube Hose-End	Holley AT812010ERL
	4	Adapter (Male 16mm Quick Connect to -10 AN Male)	Holley 97-211
	5	-10 AN Twist-On (Dynamic Swivel) 120 Degree Bent Tube Hose-End	Holley AT812010ERL
	6	AUTO-FLEX -10 Stainless Steel Braided Synthetic Rubber Hose	Holley 300010ERL
	7	Passenger's Side PCV tube	GM P/N 12681424
	8	Driver's Side PCV tube	GM P/N 12687310
	9	Oil Air Separator Tank Kit (Works With Wet Sump Only)	Holley 97-206
	10	-10 TO 1/2" NPT Adapter	Holley AT981610ERL
	11	-10 AN Twist-On (Dynamic Swivel) 90 Degree Bent Tube Hose-End	Holley AT809110ERL
	12	AUTO-FLEX -10 Stainless Steel Braided Synthetic Rubber Hose	Holley 300010ERL
	13	-10 AN Twist-On (Dynamic Swivel) 60 Degree Bent Tube Hose-End	Holley AT806110ERL
	14	Adapter (Male 16mm Quick Connect to -10 AN Male)	Holley 97-211
	15	Oil Flow Check Valve	GM P/N 12664397
	16	Adapter Kit (Oil Drain Back Check Valve Adapter to Holley Oil Pan)	Holley 97-212
	17	Holley LT Swap, Wet Sump Oil Pan	Holley 302-20

## Plumbing Options If Using the Original Oil Cooler:

Some accessory drive applications, such as LT4 wet sump, do not allow for the water pump feed to the original oil cooler if used. The below configuration allows for both custom AN plumbing and an alternate coolant source.

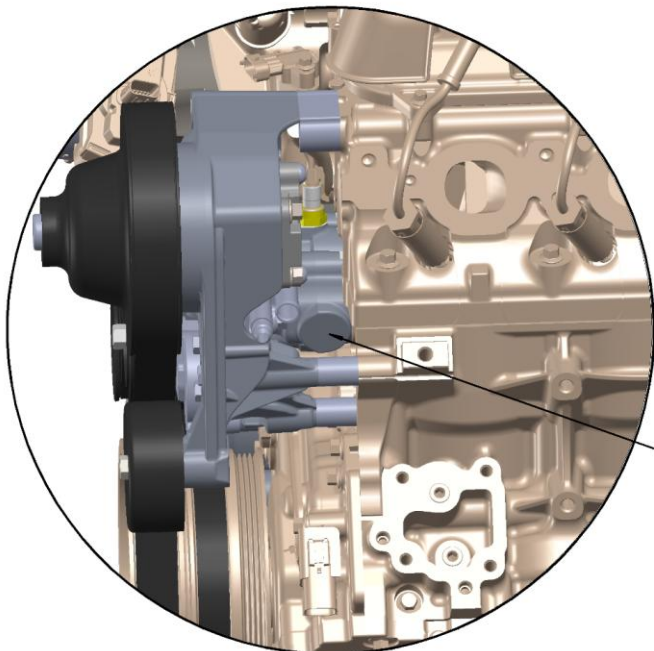
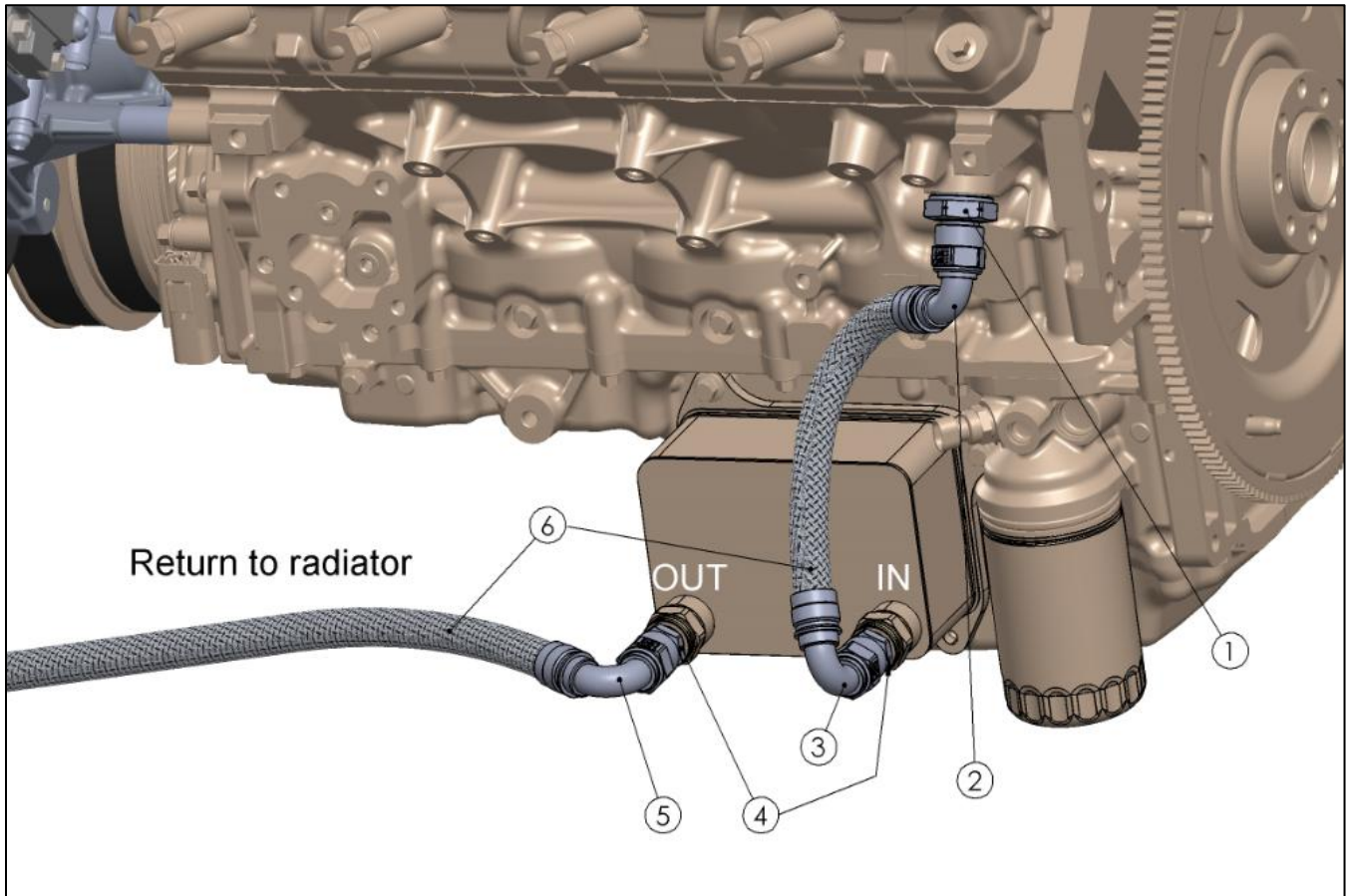

### Wet Sump Applications:

If the above coolant source is not an option on your application and you are using the Holley water pump, a boss has been provided that can be drilled and tapped for a source.

**PCV Plumbing for Air/Oil Separator System (wet sump applications only):**

**NOTE:** This system closely mimics the original LT4 wet sump PCV system and is an alternative to using an oil catch can.

Dry sump applications use the oil tank for separation functions and do not require the below system. See original equipment applications for dry sump solutions and components.

Tank vent plumbing

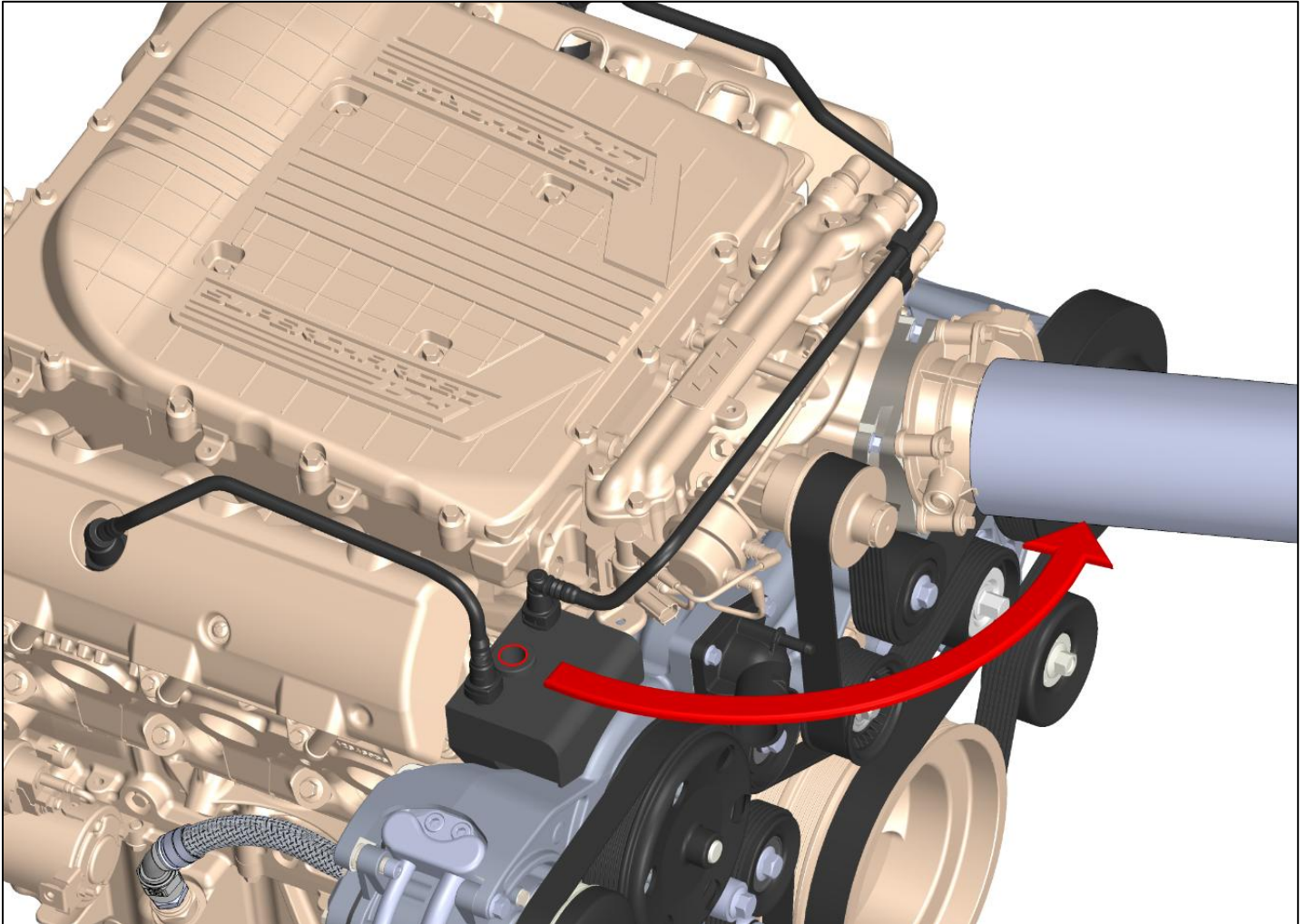

Air intake tubes vary in swap applications. The separator tank's vent plumbing will be custom for your specific situation. Earl's 90 degree 1/2" NPT to male -6 AN adapter (P/N AT982268ERL) can be used to adapt the tank vent to standard AN.

The tank vent should be plumbed to the engine intake tube. No oil should ever be present in the vent passage, but the line should be routed so any oil would drain to either the tank or the intake tube. For wrench accessibility, install this adapter before plumbing the two inlet ports on each side.

Tank feed lines and drain back plumbing with original LT4 oil pan

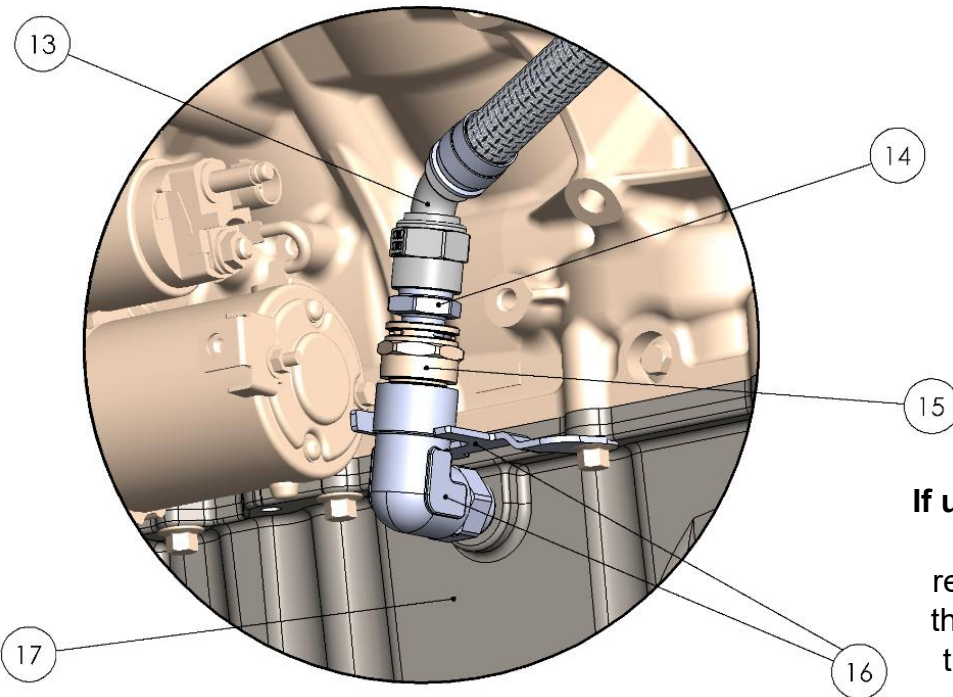
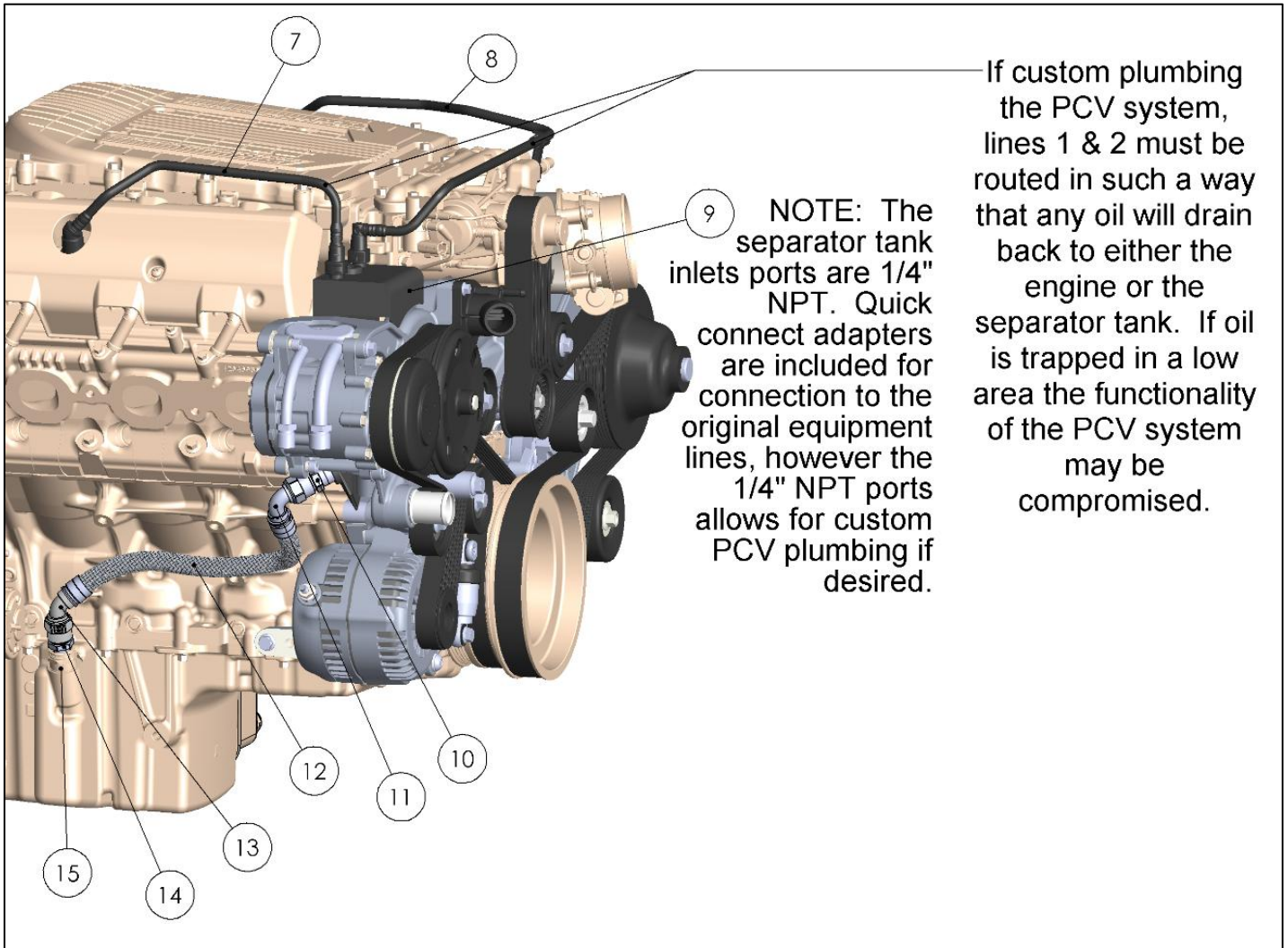



Route oil drain back hose (12) safely away from heat sources and any exhaust components.

If using a Holley swap oil pan (17), a check valve adapter (16) is required. For proper functionality, the supplied bracket must position the check valve (15) as pictured.

**Cosmetic Covers:**

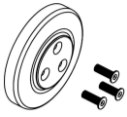
Covers are included with some kits. If not included, these can be purchased individually. See instructions included with cover for installation procedures.

PICTURE	DESCRIPTION	P/N
	A/C Compressor Pulley Cover & Hardware	Holley 97-185 (black)
	Alternator Pulley Cover & O-ring	Holley 97-187 (black)

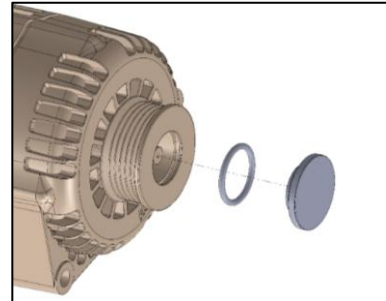
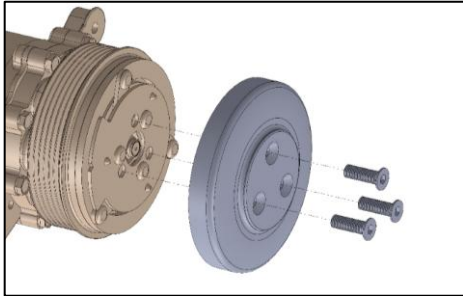

**Throttle Body Angle Correcting Adapter:**

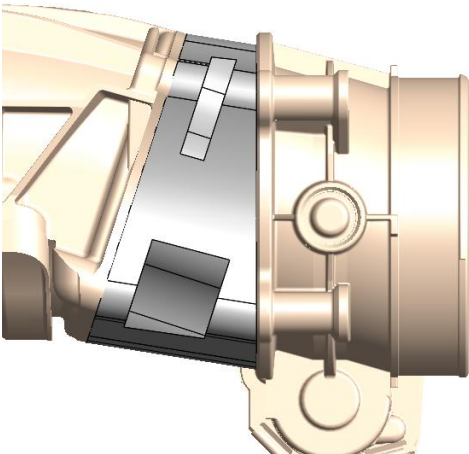

**717-15 (LT4) & 717-16 (LT5)**

**NOTE:** Installing the supplied angle adapter is recommended to increase clearance of the throttle body to the SC belt. The adapter may be required when using a larger aftermarket throttle body. See included instructions for installation procedures.

**Holley® Performance Products, Inc.  
1801 Russellville Road  
Bowling Green, KY 42101**

Technical Support: 1-866-464-6553  
Phone: 1-270-781-9741  
[www.holley.com](http://www.holley.com)

© 2019 Holley Performance Products, Inc. All rights reserved. Tous Droits Réservés.

**199R11800**  
**Revision Date: 10-9-25**