

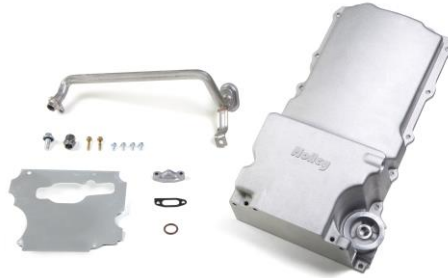

OIL PANS P/N 302-1 & 302-2



Instruction Sheet 199R10566

CONGRATULATIONS on your purchase of a Holley® **LS Retro-fit Oil Pan!** We feel that you have purchased the finest performance oil pan manufactured today. Should you need information or parts assistance, please contact our Technical Service Department at 1-866-464-6553 or 1-270-781-9741, Monday through Friday, 8 a.m. to 6 p.m. CST. Please have the part number of the product you purchased on hand when you call.

WARNING! These instructions must be read and fully understood before beginning installation. Failure to follow these instructions may result in poor performance, vehicle damage, personal injury, or death. If these instructions are not fully understood, installation should not be attempted.

Requires use of Holley 302-15 Dipstick and Tube Kit or LS3 dipstick (GM P/N 12669528) and tube (GM P/N 12625031).

INTRODUCTION:

Holley® Performance Products has written this instruction sheet for the installation of the **LS Retro-fit Oil Pan**. This instruction sheet contains all the information needed to install the oil pan. Please read all the **WARNINGS** and **NOTES**, as they contain valuable information that can save you time and money. Holley® Performance Products cannot and will not be responsible for any alleged or actual engine or other damage, or other conditions resulting from misapplication of the oil pan described herein. However, it is our intent to provide the best possible products for our customer; products that perform properly and satisfy your expectations.

APPLICATIONS:

302-1 – The Holley® P/N 302-1 LS Retro-fit oil pan is designed for LS engine retrofit installation in a wide range of popular GM muscle/classic car and truck chassis.

302-2 – The Holley® P/N 302-2 LS Gen 1 F-Body Retro-fit oil pan is designed specifically for LS engine retrofit installation in 1967-69 Camaro/Firebird (Gen 1 F-body), 1968-1974 Nova/Apollo/Omega/Ventura (Gen 1 X-body) vehicles. The 302-2 oil pan may also service other popular muscle/classic car and truck chassis where more engine-to-chassis clearance is required near the front half of the oil pan.

IMPORTANT APPLICATION NOTES:

- Both oil pans provide OEM fitment and oil filter mounting provisions.
- 302-1 & 302-2 are not intended to be used with engines that originally utilized a dry sump system.
- 302-1 is designed to use a GM full length windage tray. Depending on which full-length windage tray is used, some modification to the tray may be required. See the instructions showing the modification which may be required.
- 302-2 is designed to use a GM “F-body” windage tray, GM P/N 12558253. A modification to the windage tray is required to provide clearance to the pick-up tube. A full-length windage tray may be used if the front quarter of the tray is removed. See the instructions showing the windage tray modifications required.
- 302-2 may not be used on LS7 engines or engines with a stroke longer than 3.62”. The internal rotating assembly to oil pan clearance provided in the front half of the oil pan is patterned after a GM 98-02 LS1 oil pan.

The Holley® LS Swap oil pans are designed to work with an LS3 dipstick and tube (if desired). Below are the part numbers:

- LS Dipstick – GM P/N 12669528
- LS tube – GM P/N 12625031

NOTE: There are LS engine applications that have a plug installed in the dipstick hole location to be used with this oil pan. This plug will need to be removed before the oil pan is installed on the engine to allow the installation of the proper dipstick tube.

PAN CAPACITIES:

	<u>302-1</u>	<u>302-2</u>
Sump Oil Capacity –	5.5 Qts	5.7 Qts
Total Oil Capacity w/ stock filter –	6 Qts	6.2 Qts

PARTS NEEDED:

- Oil Pan Gasket (Mr. Gasket P/N 6665G, GM® 12612350, or equivalent)
- High Quality RTV sealer
- Oil
- Oil Filter (AC Delco® PF48 or PF48E, Mobile M1-113, Wix 57060, K&N HP-1017, or equivalent)

REMOVAL:

1. Drain the engine oil. Remove oil filter.
2. Remove the starter motor.
3. Disconnect the oil level sensor electrical connector (if equipped).
4. Remove the oil level sensor from the oil pan and set aside. The sensor will not be utilized in the Holley® pan.
5. Remove the RH transmission cover and bolt.
6. Remove the LH transmission cover and bolt.
7. Remove the bottom two transmission bellhousing bolts.
8. Remove the oil pan bolts.
9. Rotate the oil pan until it can be removed from around the oil pump pickup screen. Removal of the oil pan may not be possible with the engine in the vehicle).

NOTE: Holley® does not recommend or condone the use of the old pan gasket. A new gasket is highly recommended.

WARNING! Use extreme care when drilling the oil pan rivets to not gouge, score or damage the oil pan gasket.

10. If reusing the oil pan gasket, carefully drill out the oil pan gasket rivets (x2) if necessary (**Figure 1**).



Figure 1

11. Remove oil pan gasket.
12. Remove the oil pump pickup screen retaining bolt and nut.
13. Remove the oil pump pickup screen and O-ring, discard O-ring and set the pickup aside as it will not be re-used.
14. While the oil pan is removed, check the dipstick hole on the right side of the engine below cylinder #6 to assure that there is no plug installed and that the dipstick tube will fit in the hole.

IMPORTANT: All gasket surfaces should be free of oil or other foreign material during assembly. Inspect the engine block oil gallery passages to make sure they are free from any debris or restrictions.

IMPORTANT: The oil pan on LS engines is a structural member. The alignment of the pan is critical to provide the proper mounting points for the transmission bellhousing. The rear of the oil pan must never protrude from the rear of the block. The rear of the block and oil pan are to be flush (**Figure 2**).

IMPORTANT: Ensure that a helicoil has been installed in your pan by installing the drain plug.

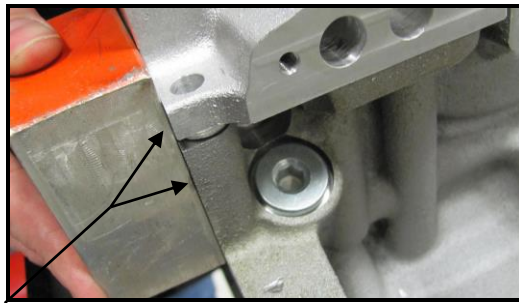

Figure 2

IMPORTANT: It is advisable to wash all of the new parts well before installing to remove any dirt or debris from the packing and shipping process.

IMPORTANT: It is advisable to test-fit the oil pan to the engine before installation to ensure that the crankshaft and connecting rods clear the windage tray, oil pump pick-up screen, and the oil pan, making a full revolution of the rotating assembly by hand.

IMPORTANT: It is advisable to mock up the engine and oil pan in the intended vehicle to ensure there is no contact of the pan to the frame or cross-members.

INSTALLATION:

1. Remove the new Holley® oil pan, parts kit, pickup screen and baffle from the box.

IMPORTANT: Ensure that a helicoil has been installed in your pan by installing the drain plug.

2. Install the supplied O-ring onto the oil pump pickup screen assembly and lubricate with clean engine oil (**Figure 3**).



Figure 3

WINDAGE TRAY INSTALLATION AND MODIFICATIONS:

P/N 302-1 OIL PAN:

WARNING! Due to the design of the Holley® oil pump pickup screen, slight modifications may have to be made to the oil deflector before the pickup screen will sit flush (**Figures 4 & 5**). Be sure to inspect this area before bolting the pickup screen into place as modifications may have to be made. GM offers an oil deflector that has the necessary clearance for the mounting bracket of the pickup screen. The GM P/N is 12611129, if modifications to the oil deflector are not desired.

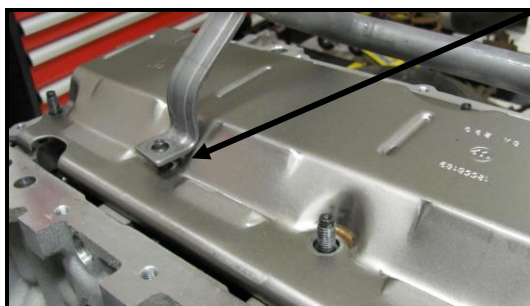

Figure 4

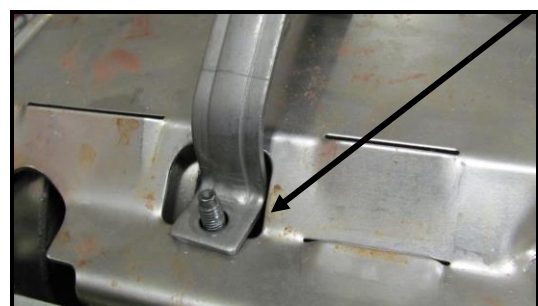

Figure 5

P/N 302-2 OIL PAN:

WARNING! The 302-2 oil pan is design to use a GM LS "F-Body" windage tray, GM P/N 12558253. Due to the design of the Holley® oil pump pickup screen, a modification to the windage tray must be made. A cut to provide clearance to the oil pick-up tube must be made as shown in **Figure 6**. The cut-out below may be used as a template for the cut.

A full-length windage tray may be used if it is modified to remove the front quarter of the tray and the required cut is made to provide clearance to the pick-up tube (**Figure 6**). A very careful check should be made to ensure that the oil pick-up tube has clearance to the windage tray and that the oil pick-up tube mounting bracket seats down properly on the mounting stud and windage tray without interference.

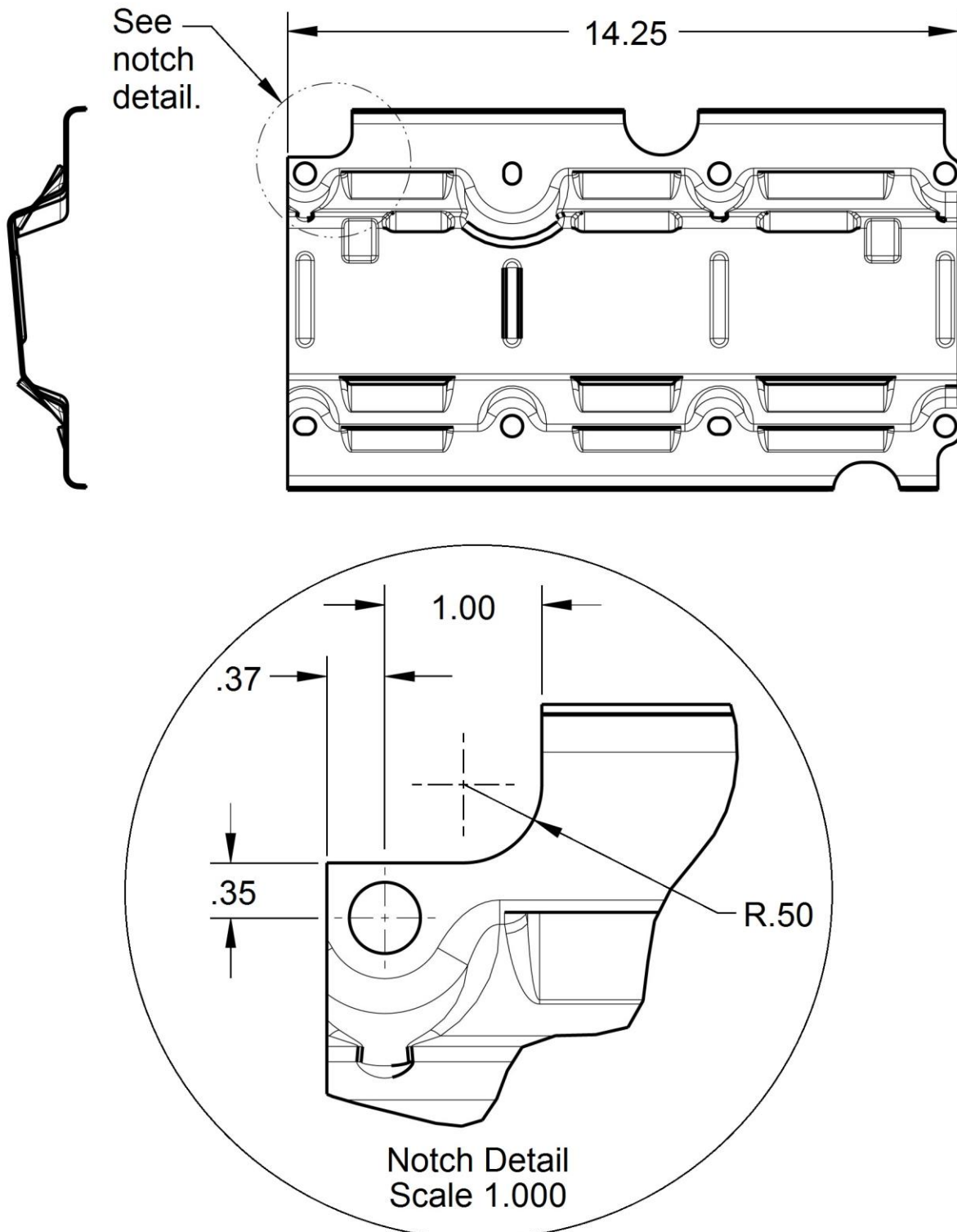

Figure 6

3. Install the new Holley® oil pump pickup screen assembly ensuring that oil pump pickup screen tube is pushed completely into the oil pump before tightening the bolt (**Figure 7**). Do not allow the bolt to pull the tube into the pump.

NOTE: Ensure the O-ring has not been pinched during installation.



Figure 7

4. Rotate the crankshaft by hand to ensure there is adequate clearance between the pickup tube brace, oil deflector, and the crankshaft counterweights.
5. Install the oil pump screen nut and bolt(s). You may need to slightly bend the tab to provide precise alignment of the hole in the tab to the mounting stud.

NOTE: The 302-2 oil pump screen/pick-up tube features a two bolt oil pump mounting flange. There are two M6 x 16mm long flanged socket head capscrews included in the installation parts kit. Use one or both of these cap screws when installing the 302-2 pickup screen. One screw is sufficient to retain the pickup screen, the second screw is optional.

6. Tighten the oil pump pickup screen bolt(s) to 106 in./lbs. and the nut to 18 ft./lbs.
7. Pre-assemble the oil pan.
8. Apply a drop of blue Loctite® to the threads of the (x4) supplied 1/4-20 x 1/2 long cap screws and use them to install the baffle into the oil pan. Torque the (x4) baffle bolts to 8-10 ft./lbs.
9. Install the supplied oil passage cover, gasket and M6 x 1.0 x 30mm long bolts to the oil pan just above the oil filter. Tighten the oil passage cover bolts to 106 in./lbs.
10. Install the new oil pan gasket to the oil pan and install the oil pan bolts to the pan through the gasket. The gasket is designed to hold the bolts in place.
11. Apply a 5mm bead of RTV sealant 20mm long to the engine block (**Figure 8**) directly onto the tabs of the front cover gasket that protrude into the oil pan surface.



Figure 8

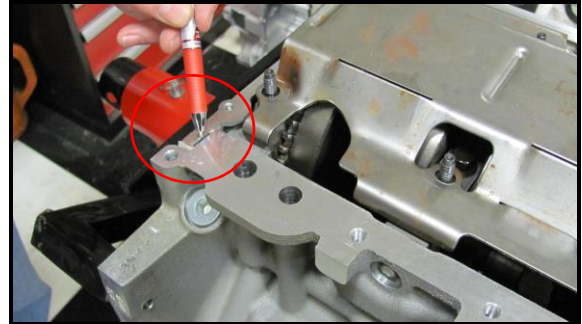

Figure 9

12. Apply a 5mm bead of RTV sealant 20mm long to the engine block (**Figure 9**) directly onto the tabs of the rear cover gasket that protrude into the oil pan surface.
13. Install the oil pan assembly to the engine block.
14. Snug all the oil pan bolts by hand (do not overtighten).
15. Install the two lower transmission bellhousing bolts until snug (do not overtighten).
16. Tighten the oil pan to block and oil pan to front cover bolts to 18 ft./lbs. (work from the center out).

17. Tighten the oil pan to rear cover bolts to 106 in./lbs.
18. Tighten the two transmission bellhousing-to-oil pan bolts to 37 ft./lbs. for either a manual or an automatic transmission.
19. Install the LH side transmission cover and bolt. Torque to 106 in./lbs. Install the RH side transmission cover and bolt. Torque to 106 in./lbs.
20. Install the supplied oil pan drain plug and tighten to 18 ft./lbs.
21. Install the supplied oil filter adapter and tighten to 40 ft./lbs.
22. Before installing the new oil filter, apply a thin film of oil to the filter gasket. Install the new engine oil filter and follow the manufacturer's recommendation for tightening procedures.
23. Fill the crankcase with the proper quantity and grade of oil.
24. Be careful not to overfill with oil.
25. Start the vehicle and check for leaks and adequate oil pressure. Use the original dipstick to verify the oil level. This should read full after 6 quarts of oil with a new filter.

Holley® Technical Support
1801 Russellville Road
Bowling Green, KY 42101
270-781-9741
www.holley.com

© 2011 Holley Performance Products, Inc. All rights reserved. Tous Droits Réservés.

199R10566
Revision Date: 8-28-20



GM F-Body LS Swap Engine Mounting Brackets P/N 12512HKR (1970-74) & P/N 12613HKR (1975-81)

Thank you for choosing to use Hooker Blackheart engine swap mounting brackets as part of your engine/transmission swap project. These Hooker Blackheart mounting brackets are part of the most comprehensively engineered system of mounting components, headers and exhaust systems available for this application. The entire Hooker Blackheart swap system is designed to decrease your total swap installation effort and cost, while increasing the engineered quality of your vehicle and compatibility of these components with other popular aftermarket components.



IMPORTANT DESIGN AND INSTALLATION INFORMATION:

YEAR RANGE	MODEL	PART #	USES TEMPLATE?	NOTES
1970-1972	Camaro	12512HKR	Yes	This part number includes a template and only this year range Camaro uses the template
1970-1972	Firebird	12512HKR	Yes	This part number includes a template and only this year range Firebird uses the template
1973-1974	Camaro	12512HKR	No	Highly recommended that new clamshell mounts be installed
1973-1974	Firebird	12512HKR	No	Highly recommended that new clamshell mounts be installed
1975-1981	Camaro	12613HKR	No (Not Included)	Highly recommended that new clamshell mounts be installed
1975-1981	Firebird	12613HKR	No (Not Included)	Highly recommended that new clamshell mounts be installed

These brackets are designed to be used in conjunction with stock OE clamshell style engine mounts, as installed on all 1972-81 Camaro vehicles (Anchor brand P/N 2292 stock rubber replacement clamshell mounts, or Hooker/Holley 71221004HKR clamshell mount cages and 71221014HKR / 71221015HKR poly inserts are recommended). Installation of the 12512HKR brackets into early model 2nd-gen F-body vehicles that were not factory equipped with clamshell mounts requires drilling holes into your vehicle's sub-frame and may require the engine to be hoisted into and out of the vehicle a few of times to verify parts fitment before final installation of the engine.

A drilling template is provided with P/N 12512HKR to properly install the clamshell mounts on 1970-1972 pre-clamshell Camaro vehicles. Installation of 12512HKR brackets on early pre-clamshell Firebird applications will also require drilling, but will use the clamshell mounts themselves as a drilling template to locate one new hole for each mount. The clamshell mounts themselves, and the long coupler bolts (7/16"x 5-1/4") and nuts (7/16") used to secure them to the Hooker Blackheart brackets are not included with these kits and will need to be purchased separately. In order to achieve the intended fitment and clearances of these components, it is highly recommended that new clamshell mounts be installed at the time of installation on 1975-81 cars and is REQUIRED on 1970 and 1972 model year vehicles that were not originally equipped with clamshell mounts.

The combined use of these mounting brackets and related Hooker Blackheart transmission swap crossmembers will allow installation of an LS engine with an 4L60/4L65/4L70/4L70 automatic or TREMEC® LS F-body/GTO T56 transmission into this application without requiring any cutting or hammering to the vehicle body with the exception of the hole for a manual shifter. Installation of a TREMEC® aftermarket T56 Magnum transmission may require floor modifications due to its larger physical size.

Unlike the stock small-block and big-block engine mounting brackets used by GM on 2nd-gen F-bodies, the designed geometry of these engine swap mounting brackets align the engine crankshaft and transmission output shaft axis just off the center-line of the chassis like stock small-block equipped 1st-gen F-body/1968-74 Nova (3rd Gen X-body) vehicles.

Related Hooker Blackheart transmission swap crossmembers share the same chassis-centered geometry of these engine mounting brackets to provide an optimized 3° to 3.5° engine/transmission inclination angle, which is the key to providing minimized U-joint working angles that are desired for lowered, performance/competition vehicles.

With these components installed, your driveline will be purposely configured with compound U-joint angles due to the close-to-center engine/transmission and the stock pinion offset of your rear differential (just like the previously mentioned stock 1st-gen Camaro/68-74 Nova). If you wish to check your U-joint working angles, you merely need to sum together the calculated horizontal angular offset of your driveline (half a degree as designed by Hooker Blackheart engineering) and the typical measured vertical angles of your driveline components. Detailed information on how to measure and calculate single plane and compound U-joint working angles is available from Spicer by going to www.spicerparts.com and search for publication number J3311-1-DSSP.

Due to the exclusive geometry designed into these Hooker Blackheart engine swap mounting brackets, attempts to install headers and/or transmission crossmembers other than those developed by Hooker Blackheart engineering will not be successful.

An engine hoist will be required to position the engine/trans into the vehicle in its proper orientation. Use of an angle-adjustable engine sling will greatly ease the hoisting/loading operation and negate the possible need to reposition the lifting chains mid-operation. An automotive lift or a jack and jack stands will be required to safely raise and support the vehicle.

CAUTION! WORK ONLY ON A LEVEL SURFACE. USE JACKS /JACK STANDS OF SUFFICIENT CAPACITY TO LIFT AND SUPPORT YOUR VEHICLE. NEVER WORK UNDER A VEHICLE SUPPORTED BY A FLOOR OR BUMPER JACK.

COMPATIBILITY:

These engine swap mounting brackets were specifically designed for bolt-in compatibility with Hooker Blackheart transmission swap crossmembers, cast iron LS exhaust manifolds, headers and exhaust systems, and Holley® LS oil pan and accessory drive components for this application.

Oil pans that are directly installable with these mounts include the Holley® **302-1, 302-2, and 302-3** LS retrofit pans, the stock F-body pan and various aftermarket fabricated steel pans.

The F-body, GTO and Corvette accessory drives are compatible with these mounts with the following exclusions:

- The stock plastic shroud on rear of the F-body alternator will have to be heavily modified or removed completely. GTO alternators will need to be swapped to an F-body unit to clear the steering box Pitman arm.
- 1970-74 vehicles will need to adopt the use of an offset Pitman arm, center link and inner tie rod ends from a 1979 Trans Am to allow installation and use of a low-mount F-body alternator.
- Corvette power steering pump pulley will likely need to be swapped for a smaller diameter pulley/pump to clear the upper control arm.
- Stock low-mount A/C compressors are not compatible with these mounts. The compressor must be upper-mounted to the right cylinder head with the use of a Holley® **20-133** (GM R4), **20-134** (Sanden SD508 or SD7), or similar bracket assembly.

If desired, a Holley® **20-135** upper-mounted Corvette style alternator/power steering bracket can be installed (swap to smaller diameter power steering pump pulley recommended for upper A-arm clearance) and is compatible with all F-body/GTO, Corvette and truck balancer/water pump offsets with the use of the following Holley® bracket spacer kits: Corvette - **21-1**, F-body/GTO - **21-2**, and Chevy/GMC truck/2010-up Camaro - **21-3**.

Two additional complete accessory drive bracket kits are available that include both the A/C and alternator/power steering brackets listed above. These kits are part numbers **20-131** (GM R4 compressor) and **20-132** (Sanden SD508 or SD7 compressor).

Hooker™ LS swap manifolds (**8501HKR**) and Hooker Blackheart long-tube headers (**70101311-RHKR/70101312-RHKR**) will all allow the use of the stock A/C evaporator case on the firewall when installed with these Hooker Blackheart LS engine swap mounting brackets.

The engine position obtained with these brackets is compatible with both the standard and optional hide-away windshield wiper motors mounted on the firewall.

More LS engine performance components, such as EFI fuel control systems, fuel filters, fuel pumps, plumbing hose/fittings and valve covers can be found at www.holley.com.

TIPS FOR A SUCCESSFUL ENGINE SWAP:

1. Check that the hardware package includes the following: (8) M10 x 1.5 x 30 Bolts, (8) 3/8"-16 x 1" bolts (**12512HKR only**), and (8) 3/8-16 flanged nuts (**12512HKR only**). If these are missing, please contact Technical Service at 1-866-464-6553 or 270-781-9741.
2. Mark all hoses, wires, and vacuum lines, according to their function. Use masking tape and a pen for this.
3. Whenever possible, utilize the existing wiring and lines.
4. Get a wiring diagram of your vehicle and one for the vehicle from which the new motor was removed. Make photocopies of both systems. Add your modifications to these copies, so you will have accurate records for future reference.
5. Think carefully before removing or defeating any emissions device. A legal engine swap requires the emissions components to be intact, especially when you try to sell the vehicle.
6. Save as much hardware that is removed from the donor engine as possible. You may need some of these items later.
7. Taking the time to do it right is cheaper than taking short cuts and having to do it again. Make sure you pay close attention to critical areas like fuel systems and brake lines. Neglecting to double-check your work could have life or death consequences.
8. Do not overstress components that are designed for stock four or six cylinder engine torque by over-abusing a motor of greater horsepower.
9. Don't forget to upgrade your radiator, fan(s), and hoses to accommodate the cooling requirements of your LS engine.

VEHICLE PREP:

1. Remove the hood from the vehicle.
2. Disconnect the battery and fuel lines.
3. Remove the existing wiring harness and set aside for later re-use of connectors, as needed, to complete electrical connections to the swap engine harness.
4. Drain all coolant and remove the radiator/hoses from vehicle.
5. Remove the driveshaft, engine, transmission and related mounts from the vehicle.

SWAP ENGINE/TRANS PREP:

1. Carefully remove the following components from the engine: spark plug wires, exhaust manifolds/O2 sensors, wiring harness/computer, MAF sensor, starter motor/plate and dust covers, A/C compressor and bracket, the oil dipstick/tube, and motor mounts.
2. Clean and paint parts to be re-used, if desired.
3. Secure engine/trans assembly to lifting sling and engine hoist.

ENGINE INSTALL:

FOR INSTALLING 12512HKR BRACKETS ON PRE-CLAMSHELL VEHICLES:

Camaro applications-

1. Remove the factory engine frame stands (brackets to which engine mounts are attached) from the sub-frame. Next, align the included drilling template with the existing holes in either side of the sub-frame following **Figure 1** on the next page and pilot drill two 3/16" diameter holes in each side of the sub-frame in the positions indicated by the template. Use 3/8" bolts as guide pins in the template "align" holes to keep it in position as you drill.
2. Rotate and flip the template to align it with the opposite side of the sub-frame as shown in the diagram and repeat the pilot drilling process. Next, use a 25/64" drill bit and enlarge all the piloted holes to their final size.
3. Using the holes you just drilled and the top holes used for aligning the template (x4 bolts total each side), attach the clamshells to the sub-frame with the included 3/8" fasteners.

Firebird applications – Remove the factory engine frame stands (brackets to which the engine mounts are attached) and align the top two holes of each clamshell mount or template with the top two holes that were used to attach the frame stands you just removed to the sub-frame. Insert 3/8" bolts into the holes for use as guide pins to hold the alignment. Next, mark the position of the bottom rearward hole of each clamshell onto the sub-frame and drill them out to a final diameter of 25/64".

NOTE: The end of the clamshell mounts with the two wider spaced holes should be at the top of the sub-frame.

FOR INSTALLING 12512HKR AND 12613HKR BRACKETS ON FACTORY EQUIPPED CLAMSHELL VEHICLES:

1. Remove existing clamshell mounts from the sub-frame and replace them with the aftermarket rubber replacement clamshell mounts, or the Hooker/Holley clamshell mount cages and poly inserts previously mentioned on page 1.

FOR ALL MODELS:

1. Raise and maneuver the engine hoist into position for installing the engine/transmission. In order to be able to lower the assembly into its proper position in the vehicle, the initial position of the sling should provide at least a 45° tilt angle of the engine/transmission.
2. Using the supplied M10 bolts, attach the Hooker Blackheart left and right engine mounting brackets. The large holes in the base plates install towards the rear of the motor.
3. Lift the assembly high enough to clear the radiator support at the front of the car. If your hoist will not go high enough to clear the support, have an assistant lift the end of the transmission up to clear it as you move the hoist under the vehicle.
4. Lower the assembly into the engine compartment, level off, and place onto the clamshell mounts (new mounts recommended).
5. Prop up and support the transmission tail shaft and then install the long coupler bolts through engine bracket ears and mounts. Install purchased nuts onto the bolts and tighten them.

6. If purchased, proceed to installing your Hooker Blackheart transmission swap crossmember and headers per the instructions included with their packaging.

Any questions? Please contact Technical Service: 1-866-464-6553 or 270-781-9741. For online help, please refer to: www.holley.com.

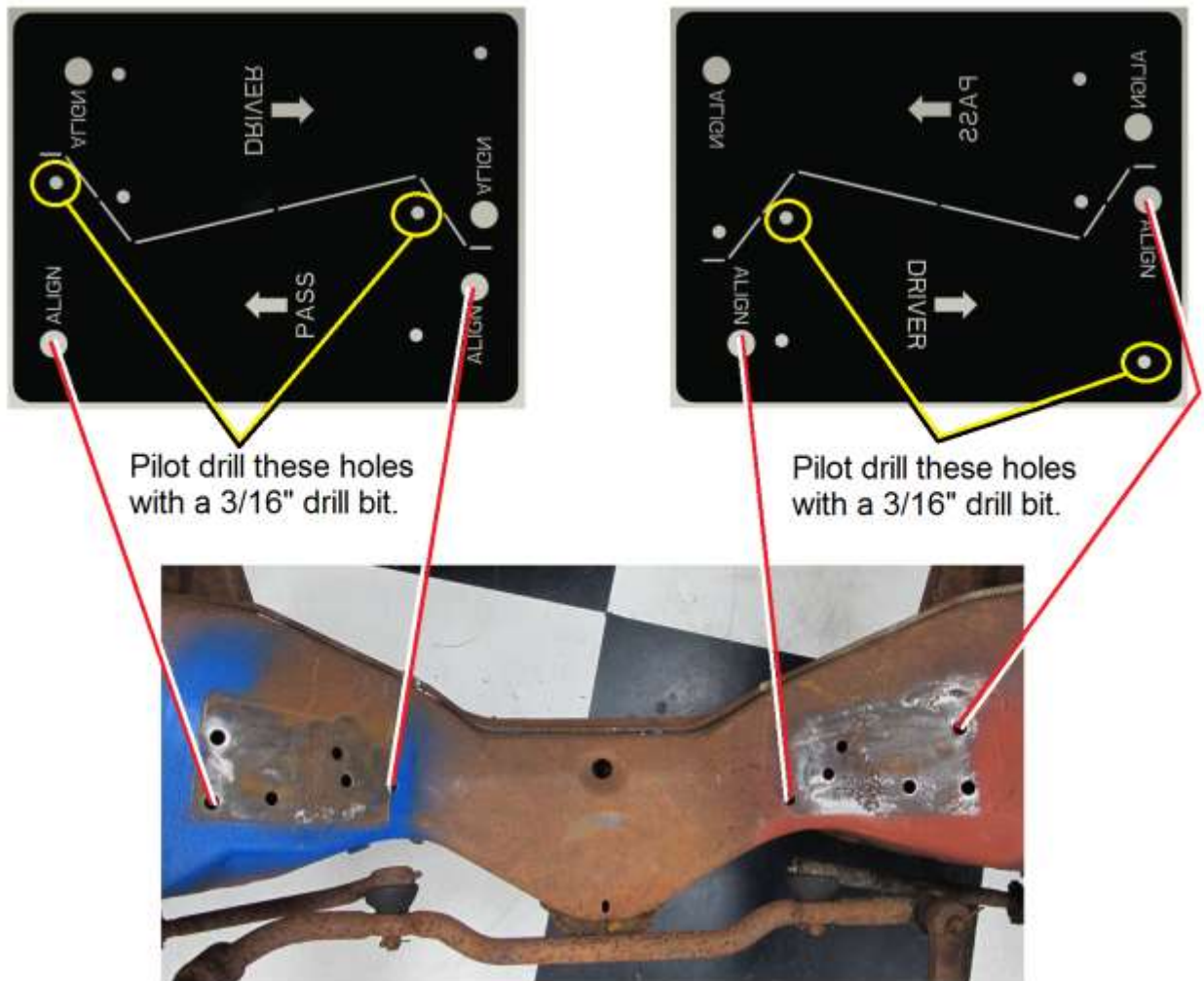

Figure 1

LIMITATION OF LIABILITY – DISCLAIMER:

The regulation of emissions production, noise levels, and safety standards is undertaken by the federal government, each of the fifty state legislatures, and by many local municipalities, towns, and counties. HOOKER™ makes no warranties of merchantability, of fitness for particular purpose, or that its products are approved for general use, or that its products comply with laws, regulations, or ordinances in the state where they may be sold to the ultimate purchaser, the consumer.

Unless expressly stated to the contrary in the catalog, instruction sheet; or price list, the entire risk as to the conformity of any company product in any such state and as to repair should the product prove to be defective or non-conforming, is on the retail purchaser, the buyer, the ultimate consumer, of such product and it is not upon the seller, distributor, or manufacturer.

In this connection, the retail purchaser, the buyer, the ultimate consumer assumes the burden of the entire cost of any and all necessary service, alterations, or repair.

THE FOREGOING STATEMENT LIMITS THE LIABILITY OF THE MANUFACTURER.

California vehicle code, sections 27156 and 38391, prohibits the advertising, offering for sale, or installation of any device, which modifies a vehicle's emission control system, unless exempted, unless otherwise noted. HOOKER™ Headers that have not received an Executive Order (E.O.) exemption from these code sections are not legal for sale or use in California on vehicles originally equipped with catalytic converters, except for racing vehicles, which may never be driven upon a highway. Check with your local authorities to determine if these headers are legal for use in your particular area.

© 2013 Holley Performance Products, Inc. All rights reserved. Tous Droits Réservés.



P/N 12614HKR

1970-81 GM F-Body LS Swap Automatic Transmission Crossmember
(GM 4L60, 4L65, 4L70 and 4L75 transmissions only)

Installation Instructions 199R10649

Thank you for choosing to use this Hooker™ transmission crossmember as part of your engine/transmission swap project. This crossmember is part of the most comprehensively engineered system of mounting components, headers and exhaust systems available for this application. The entire Hooker™ swap system is designed to decrease your total swap installation effort and cost while increasing the engineered quality of your vehicle and compatibility of these components with other popular aftermarket components.



IMPORTANT DESIGN AND INSTALLATION INFORMATION:

This crossmember is designed as part of a fully-engineered LS swap mounting system for 2nd-gen F-body vehicles. It has been CAD designed and FEA validated to provide excellent structural strength and torsional rigidity from its high-strength low-alloy steel construction. As a further benefit to the user, a maximized ground clearance pathway for routing 2.5" or 3" exhaust system tubing is included as a main design feature.

Installation of this crossmember requires the use of a stock GM 4L60/4L65 automatic transmission isolator mount from a 2003 Chevy/GMC truck or 2002 Camaro vehicle, or an aftermarket Prothane™ 7-1604 polyurethane mount or one of equivalent installed height.

Due to its unique design geometry, this crossmember must be installed in conjunction with Hooker™ 1970-74 or 1975-81 F-body LS swap engine mounting brackets to provide proper driveline operation angles and allow installation of an LS engine and 4L60/4L65/4L70/4L75 automatic transmission into this application without requiring any cutting or hammering of the vehicle body.

The related Hooker™ engine mounting brackets share the same chassis-centered geometry of this crossmember to provide an optimized 3° to 3.5° engine/transmission inclination angle that is critical to providing the minimized U-joint working angles that are desired for lowered performance and competition vehicles.

The installed geometry of this crossmember and the compatible Hooker™ engine mounting brackets align the engine crankshaft and transmission output shaft axis with the center line of the chassis, like most pro-built cars and aftermarket subframes for 2nd-gen F-bodies (like DSE for example).

With these components installed, your driveline will be purposely configured with compound U-joint angles, due to the centered engine/transmission and the stock pinion offset of your rear differential (like the previously mentioned pro-built cars and aftermarket subframes for 2nd-gen F-bodies). If you wish to check your U-joint working angles you merely need to sum together the calculated horizontal angular offset of your driveline (half a degree as designed by Hooker™) and the typical measured vertical angles of your driveline components. Detailed information on how to measure and calculate single plane and compound U-joint working angles is available from Spicer. Go to www.spicerparts.com and search for publication number J3311-1-DSSP.

A suitable lifting jack or stand will be required to install this crossmember with the appropriate transmissions for which it is intended.

COMPATIBILITY:

This crossmember was specifically designed for compatibility with Hooker engine swap mounts, cast iron LS exhaust manifolds, headers and exhaust systems and Holley® LS oil pan and accessory drive components for this application.

Oil pans that are directly installable with this crossmember include the Holley® **302-1** and **302-2** LS retrofit pan, the stock F-body, and various aftermarket fabricated steel pans.

The F-body, GTO and Corvette accessory drives are all installable with these mounts with the following exclusions:

- GTO alternators will need to be swapped to an F-body unit to clear the steering box pitman arm.
- Corvette power steering pump pulley will likely need to be swapped for a smaller diameter pulley/pump to clear the upper control arm.
- Stock low-mount A/C compressors are not installable with these mounts; compressor must be upper-mounted to right cylinder head with the use of a Holley **20-133** (GM R4), **20-134** (Sanden SD508 or SD7), or similar bracket assembly.

If desired, a Holley® **20-135** upper-mounted Corvette style alternator/power steering bracket can be installed (swap to smaller diameter power steering pump pulley recommended for upper A-arm clearance) and is compatible with all F-body/GTO, Corvette and truck balancer/water pump offsets with the use of the following Holley bracket spacer kits: Corvette - **21-1**, F-body/GTO - **21-2**, and Chevy/GMC truck/2010-up Camaro - **21-3**.

Two additional complete accessory drive bracket kits are available that include both the A/C and alternator/power steering brackets listed above. These kits are part numbers **20-131** (GM R4 compressor) and **20-132** (Sanden SD508 or SD7 compressor).

Hooker™ LS swap manifolds (**8501HKR**), mid-length headers (**2471HKR & 2472HKR**), and long-tube headers (**2295HKR & 2296HKR, 2297HKR and 2298HKR**) are compatible with most stock A/C evaporator cases on the firewall, when installed with this Hooker™ LS engine swap transmission crossmember.

More LS swap/engine performance components, such as EFI fuel control systems, fuel filters, fuel pumps, plumbing hose/fittings and valve covers can be found at www.holley.com.

Due to the unique chassis-centered geometry of its design, this crossmember is not compatible with any type or brand of universal LS engine swap plates, including those produced by Hooker. This crossmember is only compatible with **12512HKR** and **12613HKR** Hooker engine mounting bracket kits.

Use of this crossmember with half-height body bushings is only possible if relief pockets are fabricated into the floor to clear the arched humps of the crossmember and may require further floor clearance operations to clear the transmission bellhousing/case.

INSTALLATION:

Pre-installation notice: In all vehicles, this crossmember is to be installed with its mounting flanges resting in the scalloped pockets formed into the top of the subframe rails. On some earlier vehicles and depending on what transmission you are installing, the factory mounting holes present in the formed pockets will align with the holes in this crossmember and can be used for attachment purposes using two bolts/nuts per side (**Figure 1**). Later vehicles were produced with no holes in this location, which requires installation using the supplied angle brackets under the crossmember to attach the crossmember to the inside walls of the subframe through four drilled holes (**Figure 2**). If you are removing your subframe for any reason, you can also use that opportunity to drill new attachment holes in the top of the subframe and nut access holes in the bottom of the subframe to be able to attach the crossmember as shown in figure 1.



Figure 1

Top surface attachment method to top of subframe



Figure 2

Angle bracket attachment method on inside walls of subframe

This crossmember is designed to provide an exhaust routing path with maximized ground clearance. Be aware that 1970-74 models have floor pans which are lower to the top of the subframe than those of 1975-81 models and require more careful maneuvering of the crossmember into position to reduce the possibility of marring of the underside finish of the floor. Worn or collapsed body bushings will further diminish the available installation space and may require increased force or leverage to be applied to the crossmember to persuade it into proper position. It is highly recommended that new body bushings be installed prior to performing your engine/trans swap.

This crossmember provides geometry that allows the use of two OE rubber isolators (2003 GM truck or 98-2002 Camaro 4L60 isolators) for reduced drivetrain vibration characteristics, or a Prothane™ 7-1604 polyurethane isolator for more positive drive train control. The center slot in the crossmember is sized to accept the smaller stud of the OE rubber truck isolator “as-is” and must be reamed slightly larger to accept the stud size of the Camaro isolator. The slightly more forward outer slots in the crossmember are for attaching the Prothane™ isolator, which requires installation of the supplied two-hole plate spacer between the isolator and the crossmember to compensate for the difference in height between the OE rubber isolators and the Prothane™ polyurethane isolator.

WARNING! Leaving this spacer out, when using the Prothane™ isolator, will increase the engine inclination angle beyond that intended by Hooker™ and decrease the ground clearance of Hooker™ headers designed for this application.

1. Check that the hardware package includes the following:

- (2) Angle Brackets
- (4) 3/8-16 x 1" Flanged Head Bolts
- (4) 3/8" Flanged Nuts
- (4) 7/16-14 x 1" Flanged Head Bolts
- (4) 7/16" Flanged Nuts.

If any are missing, please contact Technical Service at 1-866-464-6553 or 270-781-9741.

2. Raise the tail shaft of the transmission to its highest possible point of lift.

3. Insert either end of the crossmember between the vehicle subframe and floor sheet metal

4. Shift the crossmember over far enough to allow the free hanging end to be pushed up above the height of the subframe then shift the crossmember over to center it on both mounting surfaces of the subframe. Depending on the state of condition of your body bushings, you may need to use a rubber mallet to assist in this effort.

5. If your vehicle is an earlier model with pre-punched factory holes present in the subframe at the location of the crossmember pocket, use the holes present to attach the crossmember with the supplied nuts and bolts and skip to **step 6** now. If there are no such holes in your vehicle subframe, or the ones present do not line up with the holes in the crossmember, complete steps A,B and C below before moving on to step 6.

- A. Connect the crossmember to the transmission using the isolator you intend to use in operation and lower the weight of the transmission onto the crossmember to the point where the crossmember mounting flanges are resting squarely against the mounting surfaces of the subframe
- B. Attach the two supplied angle brackets to the underside of the crossmember and seat each against the side of the frame rail; tighten the brackets against the crossmember and mark the center of all four holes located adjacent to the subframe for the purpose of drilling. Move the brackets and crossmember out of the way, pilot drill, and drill all four holes to 7/16" diameter.
- C. Move the crossmember and angle brackets back to their previous position and attach the brackets to the subframe with the supplied bolts and nuts.

Tip: While working through the open ends of the subframe rails, use a long box end wrench or paint stick with double-sided tape to capture the nuts against the inside of the subframe wall and slide them back into position at the drilled holes.

6. Securely attach the isolator to the transmission with appropriately sized bolts.

7. Attach the isolator to the crossmember with the hardware supplied with the isolator and tighten all fasteners.

Any questions? Please contact Technical Service: 1-866-464-6553 or 270-781-9741. For online help, please refer to: www.holley.com.

LIMITATION OF LIABILITY – DISCLAIMER:

The regulation of emissions production, noise levels, and safety standards is undertaken by the federal government, each of the fifty state legislatures, and by many local municipalities, towns, and counties.

HOOKER™ makes no warranties of merchantability, of fitness for particular purpose, or that its products are approved for general use, or that its products comply with laws, regulations, or ordinances in the state where they may be sold to the ultimate purchaser, the consumer.

Unless expressly stated to the contrary in the catalog, instruction sheet; or price list, the entire risk as to the conformity of any company product in any such state and as to repair should the product prove to be defective or non-conforming, is on the retail purchaser, the buyer, the ultimate consumer, of such product and it is not upon the seller, distributor, or manufacturer.

In this connection, the retail purchaser, the buyer, the ultimate consumer assumes the burden of the entire cost of any and all necessary service, alterations, or repair.

THE FOREGOING STATEMENT LIMITS THE LIABILITY OF THE MANUFACTURER.

California vehicle code, sections 27156 and 38391, prohibits the advertising, offering for sale, or installation of any device, which modifies a vehicle's emission control system, unless exempted, unless otherwise noted. HOOKER™ Headers that have not received an Executive Order (E.O.) exemption from these code sections are not legal for sale or use in California on vehicles originally equipped with catalytic converters, except for racing vehicles, which may never be driven upon a highway. Check with your local authorities to determine if these headers are legal for use in your particular area.



GM 2nd-GEN F-BODY LS SWAP HEADERS

304SS

1975-81 model years – 70101309-RHKR & 70101310-RHKR

1970-74 model years – 70101311-RHKR & 70101312-RHKR

Installation Instructions



Thank you for choosing HOOKER™ HEADERS to be part of your LS engine swap project. Your new Hooker headers are designed with optimized components and geometry to ensure the highest level of fit and performance. Please read these instructions thoroughly before attempting installation of these components.

PRE-INSTALLATION CONSIDERATIONS:

Check that the hardware package includes the following: (12) M8 x 1.25 header bolts (2) head flange gaskets (mild steel headers only). If you are missing any hardware, please contact Technical Service at 1-866-464-6553 or 270-781-9741.

These headers were specifically designed to be installed with Hooker LS swap engine and transmission mounting components and exhaust systems for this same application. Attempts to install these headers with any other type or combination of engine and transmission mounting components will cause them to no longer be bolt-in compatible with the mentioned Hooker exhaust systems.

For best balance and fit, Hooker headers and mounting components for 2nd-gen F-body LS swap applications are designed with a chassis-centered engine and transmission location, like GM 1st-gen F-bodies, 1968-74 Nova's, and other vehicles. The engine and transmission have also been located as low and rearward as possible to maximize vehicle handling performance. Using symmetrical aftermarket engine plates/brackets that retain the stock 3/8" offset and do not move the engine rearward (all existing current mounts except Hooker) will likely produce interference issues between these headers and the vehicle sub-frame.

NOTE: Will not work with factory column shift linkage. Aftermarket column linkage or cable kits such as those offered by Lokar™ and others will have to be used if you wish to keep a column shifted set-up in your vehicle.

NOTE: These headers are also not compatible with aftermarket half-height body mounts, which decrease frame-to-body clearances.

The instructions contained in this document assume you have already installed the engine and transmission in the vehicle with the above mentioned Hooker mounting components per their instructions.

An automotive lift or a jack and jack stands will be required to safely raise and support the vehicle.

CAUTION! WORK ONLY ON A LEVEL SURFACE. USE JACKS /JACKSTANDS OF SUFFICIENT CAPACITY TO LIFT AND SUPPORT YOUR VEHICLE. NEVER WORK UNDER A VEHICLE SUPPORTED BY A FLOOR OR BUMPER JACK.

VEHICLE / ENGINE PREP AND INSTALLATION:

1. Disconnect the negative cable from the vehicle battery, if connected.
2. Remove spark plug wires from the spark plugs. Removal of the spark plugs is also recommended as a precaution by not required.
3. Remove the engine oil dipstick tube.
4. Using the automotive lift or floor jack, lift the entire vehicle or front of the vehicle 12" to 15" off the ground.
5. Load both headers into general position by slipping them under the vehicle and standing them up to rest between the engine and frame rails; prop the headers up with the ends of the collectors resting on the ground surface. Reposition yourself to work through the hood or top-side of the vehicle.
6. Reach down on either side of the vehicle and pull each header assembly up into its general installed position alongside the engine. Using the supplied header bolts and gaskets (mild steel only, stainless steel headers require use/reuse of stock GM stainless shim exhaust gaskets), attach the header to the engine.
7. Repeat the same procedure for the opposite side header assembly.
8. Reinstall engine oil dipstick tube, spark plugs and spark plug wires as needed.
9. Re-connect battery if previously disconnected.

COMPATIBILITY INFORMATION:

These headers were designed and verified to produce the highest level of component compatibility of any currently available long-tube headers for this application. Compatibility with the following components is assured:

HOOKER™: engine mounts, transmission cross members and 2.5" and 3" bolt-in exhaust systems.

HOLLEY®: LS swap oil pan, accessory drive brackets, EFI fuel control systems, fuel filters, fuel pumps, plumbing hose/fittings and valve covers (www.holley.com).

Stock/Other: 1972-up clamshell engine mounts (when using Hooker mounting brackets), hydraulic or mechanical clutch linkage (custom Z-bar modification or fabrication required for manual clutch), factory AC evaporator case, straight boot spark plug wires, OE steering box Pitman arm on 1975-81 vehicles (1970-74 vehicles may need to convert Pitman arm, steering centerlink, and inner tie rod ends to those found on a 1979 Pontiac Trans AM for low-mount alternator compatibility), 4L60E (split case only)/4L65-4L75 automatic transmissions, T56 (GM LS only)/T56 Magnum manual transmissions, and Quicktime™ T56/T56 Magnum bellhousings.

LIMITATION OF LIABILITY – DISCLAIMER:

The regulation of emissions production, noise levels, and safety standards is undertaken by the federal government, each of the fifty state legislatures, and by many local municipalities, towns, and counties.

HOOKER™ makes no warranties of merchantability, of fitness for particular purpose, or that its products are approved for general use, or that its products are approved for general use, or that its products comply with laws, regulations, or ordinances in the state where they may be sold to the ultimate purchaser, the consumer.

Unless expressly stated to the contrary in the catalog, instruction sheet; or price list, the entire risk as to the conformity of any company product in any such state and as to repair should the product prove to be defective or non-conforming, is on the retail purchaser, the buyer, the ultimate consumer, of such product and it is not upon the seller, distributor, or manufacturer.

In this connection, the retail purchaser, the buyer, the ultimate consumer assumes the burden of the entire cost of any and all necessary service, alterations, or repair.

THE FOREGOING STATEMENT LIMITS THE LIABILITY OF THE MANUFACTURER.

California vehicle code, sections 27156 and 38391, prohibits the advertising, offering for sale, or installation of any device, which modifies a vehicle's emission control system, unless exempted, unless otherwise noted. HOOKER™ Headers that have not received an Executive Order (E.O.) exemption from these code sections are not legal for sale or use in California on vehicles originally equipped with catalytic converters, except for racing vehicles, which may never be driven upon a highway. Check with your local authorities to determine if these headers are legal for use in your particular area.

Technical Service: 1-866-464-6553

Phone: 1-270-781-9741

For online help, please refer to the Tech Service section of our website: www.holley.com

© 2015 Hooker Headers, Inc. All rights reserved.

199R10828

Revision Date: 7-31-15



1970-1974 GM F-body Exhaust Systems 70501385-RHKR (2.5") & 70501386-RHKR (3") Installation Instructions



Thank you for choosing to install a HOOKER™ exhaust system on your 2nd-gen GM F-body vehicle. These systems have been specifically developed for direct fitment with HOOKER™ LS swap components for this application. However, they will provide equally beneficial fitment, function, and service life with other non-Hooker LS swap headers or non-LS engine equipped F-bodies through the modification of the system inlet tubes, or construction of new ones, by a competent fabricator. Installation of these systems are 50-state legal on 1970-74 OE non-catalyst applications.

PRE-INSTALLATION CONSIDERATIONS:

Check that the hardware package includes the parts listed below. If any listed hardware is missing, please contact Technical Service at: 1-866-464-6553 or 270-781-9741.

70501385-RHKR		70501386-RHKR	
Qty.	Description	Qty.	Description
2	Over-Axle Tube Hanger Brackets with Barbed Rods	2	Over-Axle Tube Hanger Brackets with Barbed Rods
2	U-Channel Tailpipe Hanger Brackets	2	U-Channel Tailpipe Hanger Brackets
2	Rectangular Back-Up Washers	2	Rectangular Back-Up Washers
2	1/2-13 X 2" Bolts*	2	1/2-13 X 2" Bolts**
2	1/2" Nylon Lock Nuts*	2	1/2" Nylon Lock Nuts
6	3/16" X 3/8" Pop Rivets*	6	3/16" X 3/8" Pop Rivets*
4	Rubber Isolators	4	Rubber Isolators
10	2.5" Band Clamps*	10	3" Band Clamps*

*not shown in photo above

Position and support your vehicle on a suitable surface. **USE CAUTION AND WORK ONLY ON A LEVEL SURFACE USING JACKS AND JACK STANDS OF SUFFICIENT CAPACITY TO LIFT AND SUPPORT YOUR VEHICLE. NEVER WORK UNDER A VEHICLE SUPPORTED BY A FLOOR OR BUMPER JACK.** Use of a two-post under arm lift or four-post drive-on lift will considerably reduce the time and effort required to complete the installation. **MAKE SURE LIFT LOCKS ARE ENGAGED BEFORE PLACING YOURSELF UNDER THE VEHICLE.**

Your vehicle was designed to accommodate the routing of 2" exhaust tubing from the factory and therefore may require re-configuring the routing of your brake and/or fuel lines to achieve safe operating clearances between the components of this HOOKER™ exhaust system and those of your vehicle. This is extremely critical on 3" systems. Failure to provide sufficient clearance, as mentioned here, may result in an unexpected fire or the loss of vehicle control.

INSTALLATION:

NOTE: The following steps assume that you are installing this system using HOOKER™ LS swap mounting components and long-tube headers, mid-length headers, or cast iron manifolds already in place on the vehicle. If you are performing an installation of this system without utilizing these products, install all system components from the “X” crossover rearward. Then, align them for parallel alignment with the bottom of the rocker panels and sufficient clearances around all suspension, fuel, and brake components. Do all this before modifying the included HOOKER™ inlet tubes, or fabricating new inlet tubes to be compatible with the geometry of your headers and transmission crossmember.

1. Remove all existing exhaust system components from the vehicle, including any hangers added to the vehicle floor in front of the rear axle, the stock hangers above a transverse muffler and the tailpipe hangers attached to the outside faces of the rear frame. Spray all hanger fasteners with penetrating oil prior to removal and allow ample soak time before attempting to do so.
2. Place a supplied band clamp over each inlet of the crossover assembly and insert the supplied inlet tubes (tubes with a single bend in them) into the crossover assembly. The driver/left side pipe will be marked as such.
3. Now, position another clamp over the open end of each inlet tube and install the entire assembly onto the outlets of the previously installed HOOKER™ LS swap long-tube headers, or the outlets of the HOOKER™ cast iron LS exhaust manifold or LS swap mid-length header down-pipe adapters previously installed.
4. According to your preference, the emergency brake cable may be routed either below or above the crossover assembly during installation. When correctly installed, the bends in the crossover assembly outlet legs will angle up towards the floor of the vehicle, not down towards the ground. To ensure correct adjustment later, do not tighten the clamps more than what is required to hold basic component positions at this time.
5. Place a supplied clamp over the offset inlet of each muffler and install them onto the outlets of the crossover assembly. To ensure proper final adjustment, tighten the clamps only enough to maintain the general position of the mufflers at this time.
6. Feed the supplied over-axle tubes over the axle and place a supplied clamp over the inlet of each before engaging them over the muffler outlets. To ensure correct adjustment later, do not tighten the clamps more than what is required to hold basic component positions at this time.
7. Install a rubber isolator into each U-channel hanger bracket and position the supplied rectangular offset-hole washers on top of the rubber isolators. Next, install the supplied 1/2" bolts through the washers, isolators and brackets and install the lock nuts on the back sides of the brackets. Install the assembled brackets over the ends of the hanger rods welded to the tailpipes. When properly installed, the ends of the brackets with the rubber isolators will be positioned towards the front of the vehicle. Lightly oiling the rubber isolators will greatly ease their installation.
8. Place the two remaining clamps over the inlets of the tailpipes and install both with their attached hanger brackets onto the outlets of the over-axle tubes. Now attach the hanger brackets to the outside of the frame rails using the stock holes and fasteners. To ensure correct adjustment later, do not tighten the clamps more than what is required to hold basic component positions at this time.
9. Using the remaining two rubber isolators, connect the left and right muffler hanger assemblies to the barbed hangers on the over-axle tubes. When properly installed, the barbed ends of the hangers will point in towards the center of the car and be passing through the rubber isolators in the opposite direction of the hanger rods welded to the tailpipes. Lightly oiling the rubber isolators will greatly ease their installation over the barbed hanger rod ends.
10. Provide a means of support under both mufflers to keep their weight from working against your efforts to align the system components. Now align the over-axle tubes and tailpipes to achieve best fitment and clearance of the system with the vehicle.

IMPORTANT NOTE: There is an intentional 10-15 degree rotation of the mufflers designed into the system to maximize ground clearance once installed. In order to achieve the proper alignment of all system components, you must duplicate this rotation/tilt in your installation by rotating each muffler to be slightly higher on the driveshaft side than on the side facing the rear wheel.

11. Attach the muffler hangers to the underside of the floor in front of the axle using one of the following three methods:

- 1) Drill holes in floor and attach brackets with the supplied 3/16" steel pop rivets.
- 2) Enlarge holes in brackets to 1/4", drill holes in floor and attach with user supplied 1/4" -20 hardware (remove rear seat).
- 3) Plug weld holes in bracket to attach to floor (nice OE appearance, rear seat removal recommended for fire safety).

12. Once the preferred method of attachment has been decided, position the brackets against the crease in the floor sheet metal just above the seat belt attachment well, as shown in the photo below, and provide as close-to-vertical alignment of the rubber isolators as possible before marking the floor for the position of the holes to be drilled.



Hanger position against the floor - left side shown

13. Next, drill the holes and attach the hangers with rivets or fasteners, or attach the hangers to the floor by plug welding them through the holes in the brackets.

14. Align all system components for best fit and fully tighten all band clamps.

Any questions? Please contact Technical Service: 1-866-464-6553 or 270-781-9741. For online help, please refer to: www.holley.com.

COMPATIBILITY INFORMATION:

This exhaust system was designed for direct installation with various HOOKER™ LS swaps headers and engine and transmission mounting components listed for this vehicle application. If needed, additional compatible LS engine swap components, such as EFI fuel control systems, fuel filters, fuel pumps, plumbing hose/fittings, valve covers and accessory drive brackets can be found at www.holley.com.

These systems are fully compatible with Ridetech® four-link rear suspension systems for 2nd-gen GM F-bodies (both coil and air spring versions) and either stock or narrowed fuel tanks.

As shipped, the bend geometry of this system's inlet tubes (forward of the crossover) is only directly compatible with Hooker LS swap headers and transmission crossmembers for this application. As such, interference with original GM, or aftermarket transmission crossmembers and/or poor line-up issues with other headers should be expected. Such issues can be remedied through modification of the supplied Hooker inlet tubes, or the fabrication of new inlet tubes, to provide compatibility with the component geometry of your vehicle.

As there are differences in the brake line flex hose attachment points on the rear differential/axle (diff cover on early cars and left axle tube on later cars) and in the fuel tank/line plumbing between early and late 2nd-gen vehicles, steps need to be taken during installation to tie-up or re-route lines as needed. This is to prevent contact of any brake or fuel system component with the exhaust system over-axle tubes and/or tailpipes during vehicle operation. It is especially critical in the case of the larger diameter tubing used in the 3" version of the HOOKER™ exhaust system.

LIMITATION OF LIABILITY – DISCLAIMER:

The regulation of emissions production, noise levels, and safety standards is undertaken by the federal government, each of the fifty state legislatures, and by many local municipalities, towns, and counties.

HOOKER™ makes no warranties of merchantability, of fitness for particular purpose, or that its products are approved for general use, or that its products comply with laws, regulations, or ordinances in the state where they may be sold to the ultimate purchaser, the consumer.

Unless expressly stated to the contrary in the catalog, instruction sheet; or price list, the entire risk as to the conformity of any company product in any such state and as to repair should the product prove to be defective or non-conforming, is on the retail purchaser, the buyer, the ultimate consumer, of such product and it is not upon the seller, distributor, or manufacturer.

In this connection, the retail purchaser, the buyer, the ultimate consumer assumes the burden of the entire cost of any and all necessary service, alterations, or repair.

THE FOREGOING STATEMENT LIMITS THE LIABILITY OF THE MANUFACTURER.

California vehicle code, sections 27156 and 38391, prohibits the advertising, offering for sale, or installation of any device, which modifies a vehicle's emission control system, unless exempted, unless otherwise noted. HOOKER™ Headers that have not received an Executive Order (E.O.) exemption from these code sections are not legal for sale or use in California on vehicles originally equipped with catalytic converters, except for racing vehicles, which may never be driven upon a highway. Check with your local authorities to determine if these headers are legal for use in your particular area.

© 2013 Hooker Headers, Inc. All rights reserved. Tous Droits Réservés.

199R10989

Revision Date: 7-1-20



**Transmission Polyurethane Mount - GM
71223029HKR & 71223030HKR
Installation Instructions**

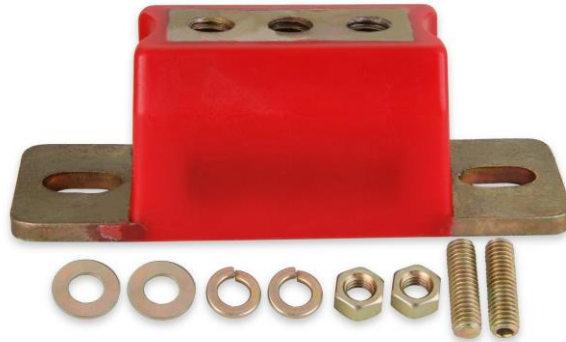

Thank you for choosing to use the Hooker BlackHeart™ transmission mount as part of your performance vehicle project. Please read thoroughly and understand these instructions before attempting installation.

PRE-INSTALLATION CONSIDERATIONS:

These polyurethane transmission mounts may be used as a direct replacement for stock GM rubber mounts that measure 1.75" in height. Replacement of mounts with a greater height than 1.75" can be accommodated with the use of shim washers between the crossmember and the mount.

The polyurethane construction is capable of high horsepower applications while preserving vibration dampening and the safety interlock design of the inner components ensures that even if the polyurethane fails the mount will not separate. These polyurethane mounts are capable of fitting either a one or two stud type of crossmember interface.

BEFORE BEGINNING:

Check that the package contains the following hardware:

71223029HKR	
Qty.	Description
1	Black Polyurethane Transmission Mount
2	7/16"-14 x 1.5" Studs
2	7/16"-14 Hex Nuts
2	Flat Washers
2	Lock Washers

71223030HKR	
Qty.	Description
1	Red Polyurethane Transmission Mount
2	7/16"-14 x 1.5" Studs
2	7/16"-14 Hex Nuts
2	Flat Washers
2	Lock Washers

INSTALLATION:

1. Determine if your application requires a one or two stud crossmember interface. Install the supplied stud(s) (7/16"-14 x 1.5") into the appropriate threaded holes in the polyurethane mount with a 7/32" hex key. If no hex key is available, the studs can also be installed into the mount by "double nutting" the end of the stud with the supplied hex nuts. Install the stud(s) until firmly seated in place.
2. Install the mount onto the crossmember with hardware provided (shown in **Figure 1**). Do not tighten the hex nuts at this time.
3. Install the factory transmission bolts (user supplied). Do not tighten the bolts at this time.
4. Confirm alignment of the polyurethane mount with the transmission and crossmember. Tighten and torque the transmission bolts to factory torque specifications. Also tighten and torque the crossmember hex nut(s) to 49 ft./lbs.

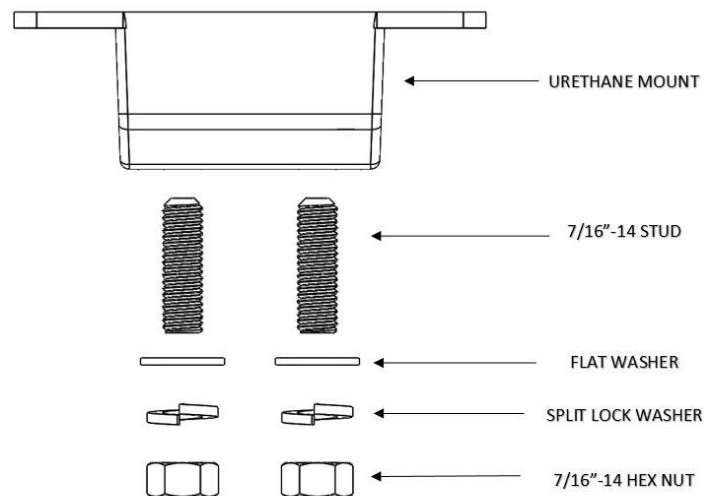

Figure 1

LIMITATION OF LIABILITY – DISCLAIMER:

HOOKER™ BLACKHEART makes no warranties of merchantability, of fitness for particular purpose, or that its products are approved for general use, or that its products comply with laws, regulations, or ordinances in the state where they may be sold to the ultimate purchaser, the consumer.

Unless expressly stated to the contrary in the catalog, instruction sheet, or price list, the entire risk as to the conformity of any company product in any such state and as to repair should the product prove to be defective or non-conforming, is on the retail purchaser, the buyer, the ultimate consumer, of such product and it is not upon the seller, distributor, or manufacturer.

In this connection, the retail purchaser, the buyer, the ultimate consumer assumes the burden of the entire cost of any and all necessary service, alterations, or repair.

© 2018 Hooker Headers, Inc. All rights reserved. Tous Droits Réservés.

199R11754

Date: 1-24-19