



7", Chevy Small Block, 12-1x Modular Crank Trigger Kit

P/N 556-171

Installation and Adjustment Instructions

1.0 Introduction

Congratulations on your purchase of a Holley Modular 12-1x magnetic Crank Trigger System! Holley Performance Products cannot and will not be responsible for any alleged or actual engine damage, or any loss or damage resulting from misapplication of the product described herein. However, it is our intent to provide the best possible products for our customer-products that perform properly and exceed your expectations. Should you need information or parts assistance, please contact our Technical Service Department at 1-866-464-6553, Monday through Friday, 8 a.m. to 5:00 p.m. Central Time; please have the part number of the product you purchased when you call.

These systems are designed to provide an engine speed & position signal to most EFI systems. The kit's 3/8", 11 or 12 magnet wheel will provide an accurate crankshaft speed & position signal to the ECU in the most-demanding of racing applications. These systems come with the bracket, mounting hardware and hall-effect sensor necessary for installation.

WARNING! These instructions must be read and fully understood before beginning installation. Failure to follow these instructions may result in poor performance, vehicle damage, personal injury or death. If these instructions are not fully understood, installation should not be attempted.

Note: On some vehicles the Crank Trigger Kit May require slight modifications to accommodate special engine plates, pulley system, etc.

2.0 APPLICATIONS

These kits were designed specifically for use on early model Small Block Chevy applications equipped with a standard, aftermarket ATI Super Damper or Fluidampr "style" harmonic balancer. The 7" trigger wheel included with these kits was designed to center off of the hub of the balancer & therefore, does not require a centering ring for wheel centering. Consequently, these kits will not work on balancers which do not have a center-hub extrusion (i.e.: Innovators West, etc.). In addition, these wheels will only work with balancers having a 3-hole, wheel mounting bolt-pattern.

3.0 PARTS INCLUDED

QTY.	Components
1	12-1x Trigger Wheel
1	Hall Effect Pickup Assembly
1	Pickup Holder Assembly
1	Connector Kit
1	Pick up Base
4	Spacers
2	7/16"-14 x 2" Bolts

Qty.	Components
2	7/16" Mil Spec Washers
2	5/16" – 24 x 1.25" Bolts
2	5/16" Mil Spec Washers
3	3/8" – 16 x 1.25" Bolts
3	3/8" Mil Spec Washers
1	Extra Magnet

4.0 INSTALLING THE PICKUP AND BRACKET

1. Mount the pickup holder onto the bracket using the two fine thread bolts. **(Figure 1)** The pickup base will only install one way, do not try to force the bolts in, and hand tighten the bolts.
2. Install the bracket onto the engine. The bracket may be mounted on either side of the balancer. Use the correct length bolts and shims in the proper location to insure the wheel is centered with the pickup. **(Figure 2)**
3. Install the pickup and locknut onto the holder. Do not tighten the locknut at this time.

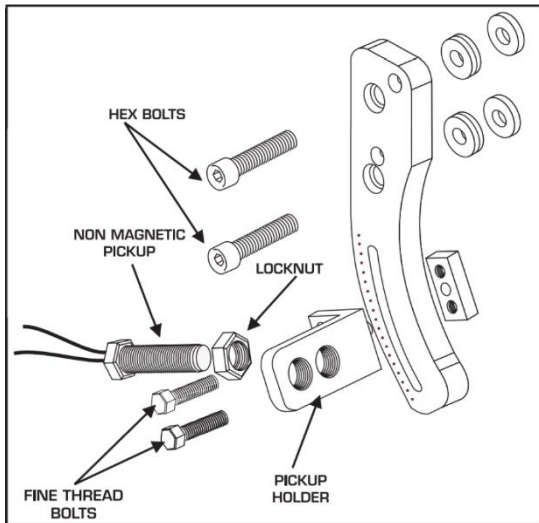

Figure 1: Pickup Bracket Assembly

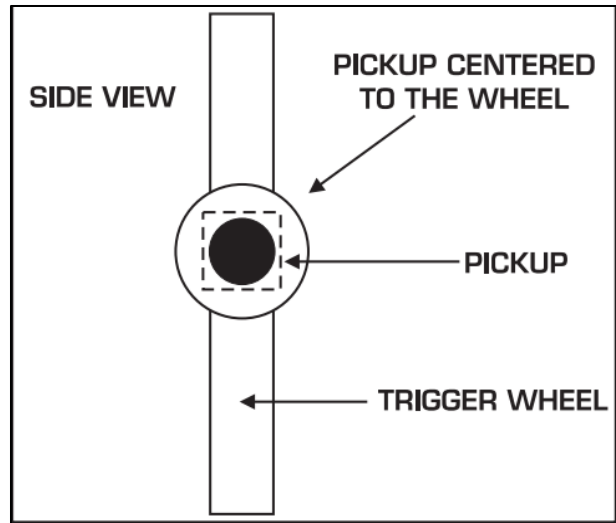

Figure 2: Pickup Centered on the Trigger Wheel.

5.0 INSTALLING THE TRIGGER WHEEL (12-1X SETUP)

1. Manually rotate the engine to TDC (Top Dead Center) of the #1 cylinder as shown in **Figure 3** below.
2. Check the hub surface to which the crank trigger wheel will be mounted to ensure that it is smooth & free of any excess dirt, debris, or oil. Clean the face of the balancer as required.
3. With the wheel's flat side (side with arrow) facing outward, center the wheel on the hub of the balancer using the recess on the rear of the wheel.
4. Rotate the crank wheel until the 2nd-tooth (Magnet, black insert) after the red insert lines up with the approximate centerline of the sensor. **Figure 4 and 5** show two examples. The wheel was designed such that the bolt-holes on the wheel should line up to those of the balancer under these conditions. This should provide an ignition reference angle of 60° BTDC #1, assuming TDC was properly identified.

When using Holley EFI:

- Cam Sync location (degrees BTDC #1) = 60 deg Crank Reference Angel + "A" + ("A"/2)
 - "A" = Angle Between Crank Pulses (crank degrees between triggers on crank sensor)
 - "A" for 8 cylinder = 90
 - "A" for 6 cylinder = 120
 - "A" for 4 cylinder = 180

Example: Typical V8 = 60 + 90 + 45 = 195 degrees BTDC for Cam Sync trigger.

5. Adjust the wheel as necessary to align the bolt holes & secure the crank wheel to the balancer using the supplied 3/8"-18 x 1.25" screws & 3/8" washers. Apply medium-strength thread adhesive (minimum) to the threads of the screws prior to tightening.
6. Once the crank wheel has been securely fastened to the balancer, make any final sensor-to-wheel angular adjustments by sliding the sensor bracket in the engine-block bracket until the sensor's centerline is located directly on the 2nd tooth. Use a 1/2" wrench to tighten the sensor bracket in place. Thread locker is recommended on the threads of the 5/16"-24 screws prior to final tightening.

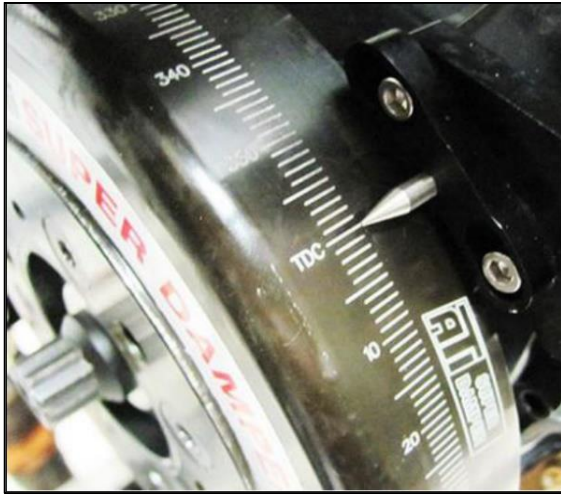

Figure 3: Rotating Engine to TDC #1

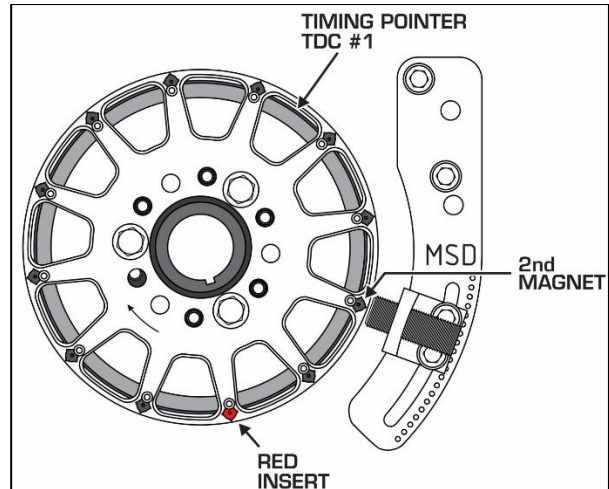

Figure 4: (Example) Aligning 2nd tooth, Driver Side Mounting

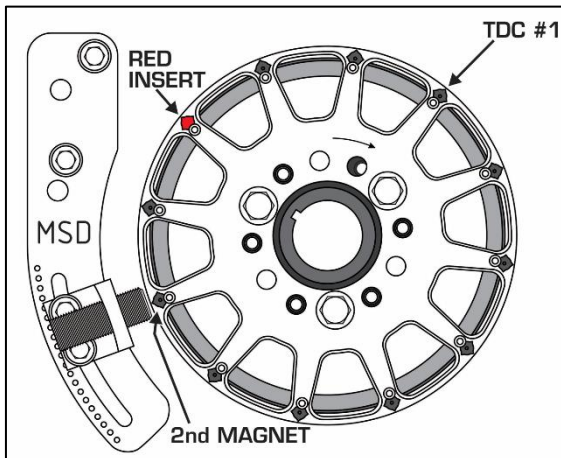

Figure 5: (Example) Aligning 2nd tooth, Passenger Side Mounting

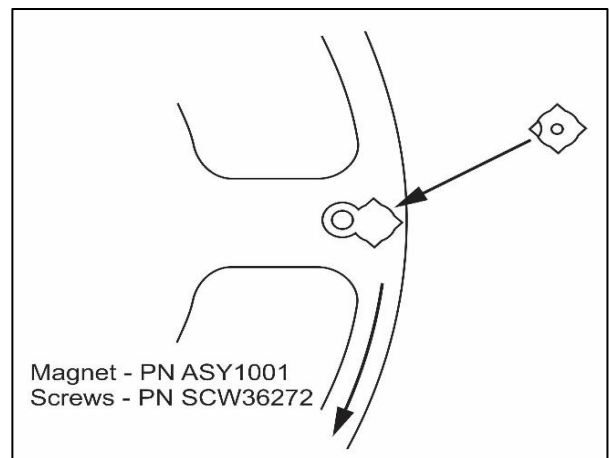

Figure 6: Installing the Magnet

6.0 INSTALLING THE TRIGGER WHEEL (12X SETUP)

Removing and replacing red insert (12-1x) with black magnet (12x):

1. On a flat, sturdy surface, place wheel and with a Opt. Phillip screwdriver remove the #6-32 flat head screws from both sides. These are thread locked in, keep constant downward pressure while removing to prevent cam out.
2. Once the screws are removed, gently press or punch the red insert out.
3. Determine which side of the wheel will face out.
4. Install the magnet in the wheel with the hole in the plastic over molding facing out from the engine (**Figure 6 above**). The chamfer on the magnet must be positioned next to the chamfer on the wheel.
5. Install the screws with blue thread locker to 5 to 7 lbf-in.

Wheel Install:

1. Manually rotate the engine to TDC (Top Dead Center) of the #1 cylinder as shown in **Figure 3** above.
2. Check the hub surface to which the crank trigger wheel will be mounted to ensure that it is smooth & free of any excess dirt, debris, or oil. Clean the face of the balancer as required.
3. With the wheel's flat side facing outward, center the wheel on the hub of the balancer using the recess on the rear of the wheel.
4. Rotate the crank trigger wheel until any magnet lines up with the pickup approximate centerline. Since all magnets are spaced 30 degrees apart, an adjustable cam sync pickup / sensor will be required for the Holley ECU to properly compute the desired Ignition Reference Angle. The wheel was designed such that the bolt-holes on the wheel should line up to those of the balancer under these conditions.

When using Holley EFI:

- Recommended Reference Angle = 60 degrees BTDC. Cam Sensor location should be between 90 and 120 degrees BTDC (Between magnets 3 and 4 from crank sensor location while engine is at TDC #1)
5. After the necessary adjustment are made, secure the crank wheel to the balancer using the supplied 3/8" - 18 x 1.25" screws & 3/8" washers. Apply a liberal amount of medium-strength thread adhesive (minimum) to the threads of the screws prior to tightening.
 6. Once the crank wheel has been securely fastened to the balancer, make any final sensor-to-wheel angular adjustments by sliding the sensor bracket in the engine-block bracket until the sensor's centerline is located directly on the magnet. Use a 1/2" wrench to tighten the sensor bracket in place. Thread locker is recommended on the threads of the 5/16"-24 screws prior to final tightening.

7.0 Setting the Air Gap

1. The air-gap between the trigger wheel and the pickup is important to the operation of the crank trigger system, however its adjustment does not affect engine power or performance. The proper air-gap will result in a good trigger signal at cranking rpm through high rpm with no interference to the wheel. The optimum setting is generally between 0.050" – 0.080".
2. With the brackets and trigger wheel mounted (with the arrow on the wheel facing out) position the pickup within 0.050" – 0.080" from the wheel using a feeler gauge then tighten the locknut (**Figure 7**). Do not over tighten the locknut.

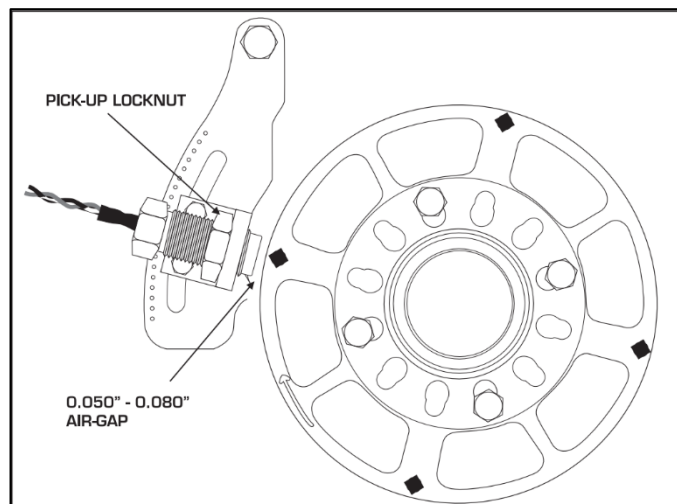

Figure 7: Setting the Air Gap.

8.0 SENSOR WIRING & SETUP

Loose pins and seals are included and must be crimped onto an existing harness like Holley P/N 558-431 or 558-306. Use the proper tools to crimp Metripak 150 style pins (Aptiv P/N: 12014254 – Available through Waytek, Inc. Item No. 440). It is advised to use shielded wiring (with drain wire grounded at the ECU end) to connect to this sensor. The pins are inserted into the back of the connector. Install the TPA lock (14) after the wires are inserted.

The following is the proper wiring for this sensor:

- A – Red – 8V to 20V clean switched power. Pin B20 (“EST 12V Output”) on Holley EFI systems would be a good choice. Pin E at the “Ignition” connector of Holley P/N 558-431 or 558-306.
- B – White – Sensor Output to ECU crank signal (Pin A30 on Holley EFI). Pin A at the “Ignition” connector of Holley P/N 558-431 or 558-306.
- C – Black – Sensor ground. Connect to a “clean” ECU ground, such as pin A14 (“IPU Ground”) on Holley EFI systems.

9.0 INITIAL FIRE UP TIMING CHECK.

If using Holley EFI, set initial ignition software parameters, as seen in **Figure 8 and 9, for 12-1x and 12x setup respectively,** below.

Verify Ignition Timing:

1. Power on Ignition
2. Set Static Timing
 - a. via the Software click the right arrow next to the “Syncing with ECU” icon. 
 - b. Select Static Timing.
 - c. Set the value of Static timing to a value easily seen on your balancer/timing pointer.
3. Start the engine.
4. Validate the timing matches the commanded value using the Static Timing Set.
5. Shut the engine off.
6. If they do not match, physically move the crank trigger sensor mount and repeat the above procedure until the timing matches the commanded timing via the Static Timing Check.

Figure 8: 12-1x Crank Sensor Setup in Holley EFI V6 Software

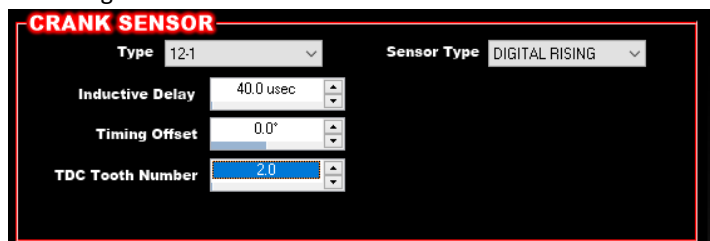
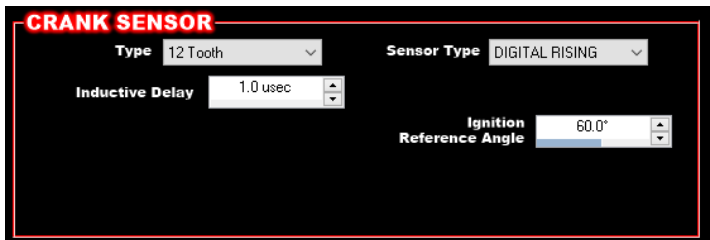

Figure 9: 12x Crank Sensor Setup in Holley EFI V6 Software



HOLLEY TECHNICAL SUPPORT: 1-866-464-6553

Holley Performance Products, Inc.©

FRM36691

Rev.1/23