



## 2-PIECE LS VALVE COVERS – VINTAGE FINNED, NO LOGO

- 241-180 – Natural Cast Finish
- 241-181 – Polished Finish
- 241-182 – Satin Black Machined Finish
- 241-183 – Factory Orange Machined Finish
- 241-184 – Gloss Red Machined Finish

### INSTRUCTION SHEET P/N 199R11666

#### PARTS LIST:

QUANTITY	DESCRIPTION
2	2-Piece LS Valve Cover Base w/ Oil Fill Hole
2	2-Piece LS Valve Cover OverCover
2	Low Profile Billet Oil Fill Cap w /O-ring
8	12-Point OverCover Dress-Up Bolts
8	SS Washers for OverCover Dress-Up Bolts
16	Gen I LS Coil Spacers
16	Gen V LS Coil Spacers
16	Coil Mounting Bolts - 1/4"-20 Thread, 1-1/4" Long
1	Warranty Sheet
1	Instruction Sheet

#### RECOMMENDED TOOLS FOR INSTALLATION:

3/8" Drive Ratchet	Torque Wrench	Flat Head Screwdrivers
10mm 3/8" Drive Socket (for Coil Mounting Bolts)	7mm 3/8" Drive Socket (for 12-point Overcover Bolts)	8mm 3/8" Drive Socket (for OE LS Valve Cover Bolts - Not Included)

#### APPLICATIONS:

Fits LS1, LS2, LS3, LS6, and LS7 engines. These valve covers feature integrated coil mounts that were designed specifically to fit Gen I and Gen V style LS coil bodies (OEM and aftermarket).

**GEN I STYLE LS COIL BODY INFO**  
Coils Not Included - Shown for Illustrative Purposes Only



Gen I Style LS Coil Body  
Part Numbers:

GM: 12558948  
MSD: 8262 / 82628, 82623 / 826283  
AC Delco: D580

**GEN V STYLE LS COIL BODY INFO**  
Coils Not Included - Shown for Illustrative Purposes Only



Gen V Style LS Coil Body  
Part Numbers:

GM: 12570616  
Holley: 410004  
Accel: 140043 / 140043-8, 140043K / 140043K-8  
MSD: 8265 / 82658, 82653 / 826583  
AC Delco: D510C

## OPTIONAL PARTS:

These valve covers do not include valve cover mounting bolts or rubber grommets. You may re-use your factory bolt assemblies, or other factory height hardware of your choice, though replacements may be necessary over time.

Purchasing new valve cover gaskets is recommended, but not required.

**Carefully inspect all components that will be reused before installation to determine if a replacement part may be necessary.**

LS Valve Cover Gaskets (Set of 2):  
*Mr. Gasket Part # 61040G*

LS Valve Cover Bolt Grommets (Set of 8):  
*Fel-Pro® Part # ES72233*

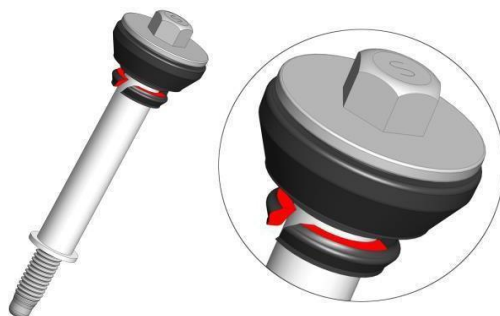
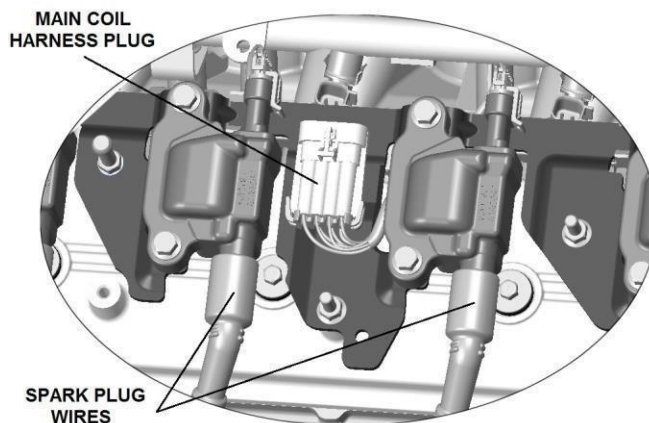

**Figure 1 – Factory LS Valve Cover Hardware Assembly**

**NOTE:** Aged grommets will likely tear during the removal and reinstallation processes. The area that is affected is only for temporary retention during installation and will not hurt the sealing function of the grommet.

## INSTALLATION:

1. Before beginning, blow any loose debris off the engine using an air hose.
2. Disconnect the battery.
3. Remove any cosmetic engine/coil covers. Refer to the vehicle's service manual for proper removal procedure. If these covers mount to the original valve covers, they will not be reinstalled.
4. Disconnect the plug wire from each coil by twisting and pulling on each wire boot.
5. Disconnect the main coil harness plug as shown in **Figure 2** below.



**Figure 2**

6. Remove the coils, coil brackets, coil harnesses, PCV hose, and existing valve covers from the vehicle.
7. Remove the original LS valve cover gaskets by gently pulling them out of the valve cover grooves.
8. Remove the valve cover retention bolt assemblies by carefully working the grommets out of the original valve covers. The original grommets are likely to have softened and swelled with age.

**NOTE:** If reusing the original grommets and gaskets, clean with only mild soap and hot water. Chemicals may damage the material and greatly affect their sealing ability.

9. Reinstall the gaskets by working them into the grooves in each Holley 2-piece LS valve cover base. The gaskets will be slightly long as compared to the grooves and will need to be evenly worked around the cover distributing the extra length. Press firmly to properly seat the gasket.
10. Reinstall the factory LS valve cover retention bolts by carefully working each hardware assembly (bolt, spacer, and grommet) into each valve cover base until the grommet is fully seated against the surface of each hole.
11. Install each Holley 2-piece LS valve cover base onto the engine, making sure the gasket remains seated in the valve cover groove and the bolts are making contact with the threads in the cylinder head. Evenly torque each valve cover retention bolt to **106 in/lb (9 ft/lb)**.

**NOTE:** The Holley 2-piece LS valve covers are designed to be used with rocker arms and lift ratios compatible with stock LS valve covers. If using aftermarket valve train components, refer to the manufacturer's instructions for compatibility.

12. Remove the corresponding rubber caps on the internally baffled ventilation tubes of your 2-piece LS valve cover bases and reconnect the PCV/ventilation hose(s).

**NOTE:** Some applications, as pictured below, have internal PCV restrictions inside the cover assembly. If your application utilizes this type of connection, an external PCV valve must be added in-line on the hose.

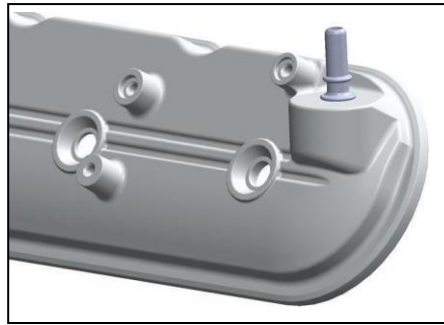

If required, a suggested PCV valve is: Beck/Arnley® P/N **143-0450299** or similar

13. Remove the coil bodies from the original bracket and install them onto the corresponding mounting posts on each Holley 2-piece LS valve cover base. Be sure to use the correct coil-specific spacers for your application and the included coil retention bolts. As shown in the diagram below, different upper coil mounting holes are used for Gen I and Gen V style LS coil bodies. Torque each coil retention bolt to **106 in/lb (9 ft/lb)**.

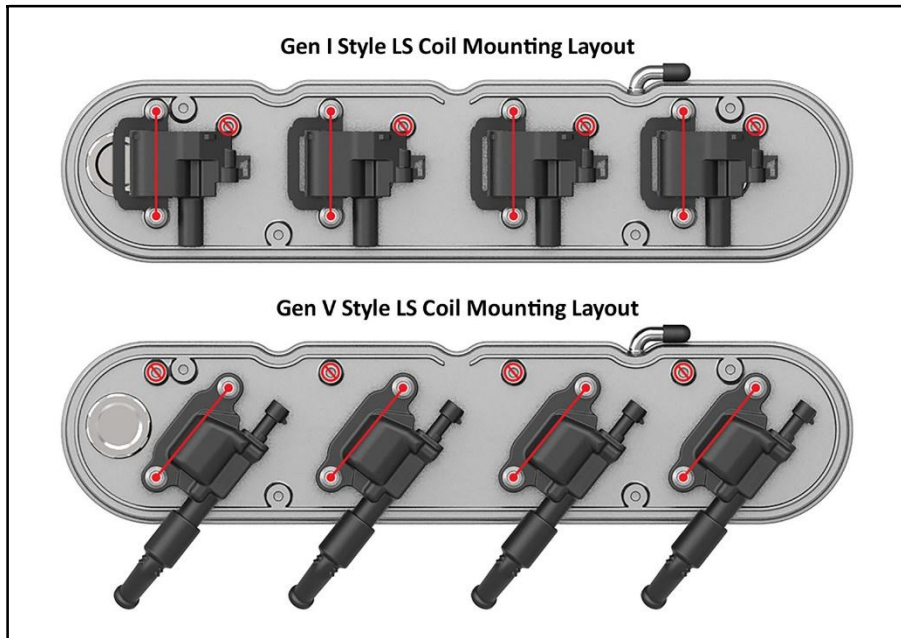

**Figure 3**

14. Remove the coil harnesses from the original brackets and plastic conduits. Reconnect the coil harnesses to the individual coils that were mounted onto each 2-piece LS valve cover base. Make sure the coil harnesses are not switched to the opposing sides and that each corresponds to the same coil that it was removed from - if harnesses are accidentally switched, the firing order will be wrong. Neatly tuck the wires around the mounted coils and route the main harness so that it will fit through the hole in the valley side of the overcover once installed.
15. Install the 2-piece LS valve cover overcover using the supplied dress-up bolts and stainless steel washers. When installing the overcover with Gen V LS coil bodies, first carefully slide the ends of the coils through the plug wire holes in the cover, and then rotate the cover lengthwise to route it around the coils and wiring harness. Be sure to check that the main coil harness clears the valley side exit hole and is not being pinched.
16. Reinstall the spark plug wires and rotate the boots for maximum exhaust clearance and visual appeal.
17. Make sure all electrical connections are secure and reconnect the battery.
18. Start the vehicle and verify that there are no oil leaks.

## OIL FILL CAP:

The billet cap threads into each valve cover base and should be turned clockwise to install and counter-clockwise to remove.

**NOTE:** Oiling the billet fill cap's O-ring (**Figure 4**) will ease the cap removal/reinstallation process and is recommended.

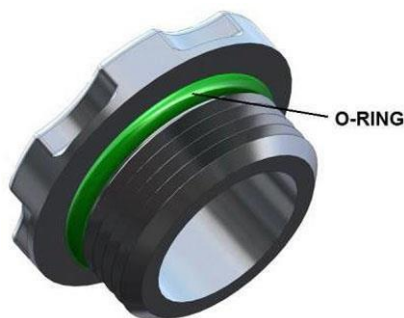

**Figure 4**

**Holley Technical Support  
1801 Russellville Road  
Bowling Green, KY 42101  
270-781-9741 or 1-866-464-6553  
www.holley.com**

© 2019 Holley Performance Products. All Rights Reserved. Tous Droits Réservés.

**199R11666  
Date: 7-2-19**