



P/N 5113HKR (painted) & 5113-1HKR (ceramic coated) SUPER COMPETITION FULL LENGTH MOPAR HEADERS

1968-74 Monaco/Polara/Fury I, II, III (C Bodies) 383-440

NOTE: Hooker headers for MOPAR 383-440 engines will bolt on the popular aftermarket B-S heads. However, because the exhaust port centerline on these heads is 5/8" higher and 3/8" out from the engine centerline compared to stock heads, some header modifications will be required for installation. Custom header applications will be required to fit the B-1 heads because of the angled spark plug location.

NOTE: Will not fit motors equipped with air injection pump without modification.

WARNING! Breaking in an engine with ceramic-coated headers WILL result in damage to the coating and will VOID all warranties. Ceramic-coated headers require several heat cycles to fully cure before they will withstand extreme heat. HOOKER recommends using a cast-iron exhaust manifold or an old header to break in new engines to avoid coating damage.

BEFORE STARTING

Your vehicle must be raised a minimum of 36 inches. A floor hoist is ideal. If no hoist is available, we strongly urge the use of axle stands as a safety measure.

CAUTION! YOUR CAR SHOULD NOT BE SUPPORTED ON A BUMPER JACK.

INSTALLATION PROCEDURE – PLEASE READ CAREFULLY

See Figures 2 & 3 for transmission shift linkage modification.

LEFT SIDE:

1. Disconnect battery cable to prevent damage to the electrical system.
2. Unbolt the headpipe from the stock exhaust manifold and push aside.
3. Remove the stock exhaust manifold, spark plugs, starter, and drag link from Pittman arm and idler arm. Move the Pittman arm toward the outside of the car.
4. Remove the bolt from the dipstick tube bracket and bend the dipstick tube over against the steering box.
5. For best results, drain the radiator and remove the studs.

NOTE: If the automatic shift linkage on your vehicle extends below the torsion bar, it must be modified as shown in **Figure 2**. It may be necessary to bend the shift linkage approximately 1/4" if the linkage hits the L2 header tube when in the "drive" position. See **Figure 3**.

6. Starting from below, work the header with the starter into position.
7. Position the header gasket and start all bolts (most restricted first). Do not tighten.
8. Reinstall the starter making sure none of the wires will come in contact with any of the header tubes.
9. Tighten all bolts (most restricted first).

NOTE: For best results, we recommend the use of a sealant on all header bolts to prevent leakage of coolant.

10. Modify and install the dipstick tube as shown in **Figure 1**.
11. Replace the spark plugs and drag link.
12. Check to be sure that all brake lines, fuel lines, and electrical wires have sufficient clearance. Reroute as necessary.

NOTE: Vehicles equipped with factory air conditioning mounted to the front stud in the left cylinder head must reinstall the air conditioning bracket using the stock stud and nut.

RIGHT SIDE:

1. Remove the stock exhaust manifold, spark plugs, and studs.
2. Remove the drag link from the Pittman arm and idler arm. Turn the idler arm toward the outside of the car.
3. Remove the center bolt from the motor mount and jack up the engine approximately 2".

NOTE: Place a flat board between the oil pan and hydraulic jack to prevent any damage to your oil pan.

4. Starting from below, work the header through the chassis into position.
5. Position the gasket and start all bolts (most restricted first).

NOTE: For best results, we recommend the use of a sealant on all header bolts to prevent leakage of coolant.

6. Lower the engine and replace the motor mount bolt.
7. Replace the drag link to the idler arm and Pittman arm.
8. Tighten all bolts (most restricted first).
9. Refill the radiator and replace the spark plugs.
10. Check to be sure that all brake lines, fuel lines, and electrical wires have sufficient clearance. Reroute as necessary.
11. To connect the collectors to your stock exhaust system, use Hooker Reducer Kit #11030HKR.

NOTE: Transmission dipstick tube may have to be bent towards the motor slightly to allow for adequate clearance of the header.

12. Connect the battery, start the engine, and check for leaks.
13. When finished, give your vehicle a test drive, checking carefully for any new noises. After several days of driving, retighten all bolts.

Any questions? Please contact Technical Service: 1-866-464-6553 or 270-781-9741. For online help, please refer to the website: www.holley.com.

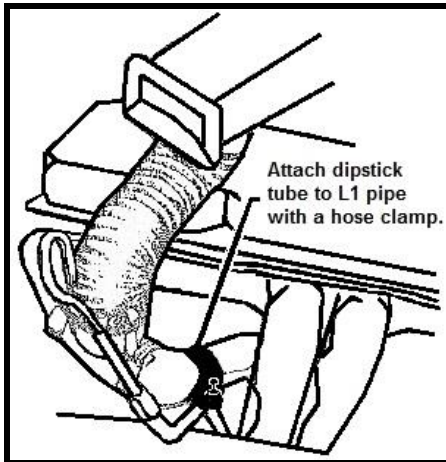

Figure 1

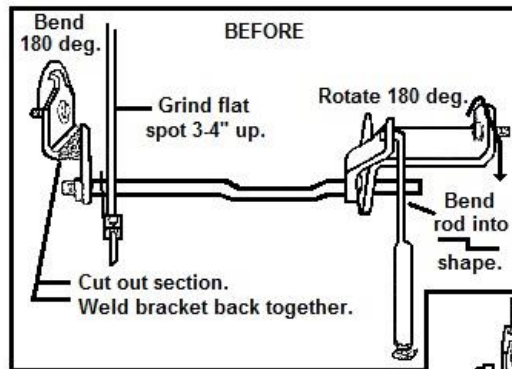

Figure 2

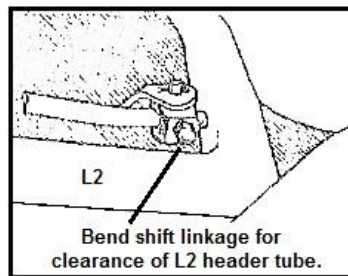
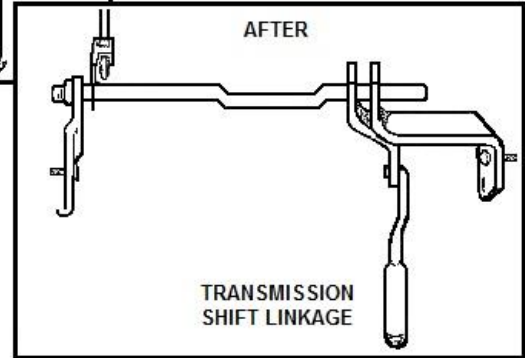

Figure 3

LIMITATION OF LIABILITY – DISCLAIMER:

The regulation of emissions production, noise levels, and safety standards is undertaken by the federal government, each of the fifty state legislatures, and by many local municipalities, towns, and counties.

HOKKER makes no warranties of merchantability, of fitness for particular purpose, or that its products are approved for general use, or that its products are approved for general use, or that its products comply with laws, regulations, or ordinances in the state where they may be sold to the ultimate purchaser, the consumer.

Unless expressly stated to the contrary in the catalog, instruction sheet; or price list, the entire risk as to the conformity of any company product in any such state and as to repair should the product prove to be defective or non-conforming, is on the retail purchaser, the buyer, the ultimate consumer, of such product and it is not upon the seller, distributor, or manufacturer.

In this connection, the retail purchaser, the buyer, the ultimate consumer assumes the burden of the entire cost of any and all necessary service, alterations, or repair.

THE FOREGOING STATEMENT LIMITS THE LIABILITY OF THE MANUFACTURER.

California vehicle code, sections 27156 and 38391, prohibits the advertising, offering for sale, or installation of any device, which modifies a vehicle's emission control system, unless exempted, unless otherwise noted. HOKKER™ Headers that have not received an Executive Order (E.O.) exemption from these code sections are not legal for sale or use in California on vehicles originally equipped with catalytic converters, except for racing vehicles, which may never be driven upon a highway. Check with your local authorities to determine if these headers are legal for use in your particular area.

© 2000 Holley Performance Products, Inc. All rights reserved.

**5113HKR
Revision Date: 5-10-19**