

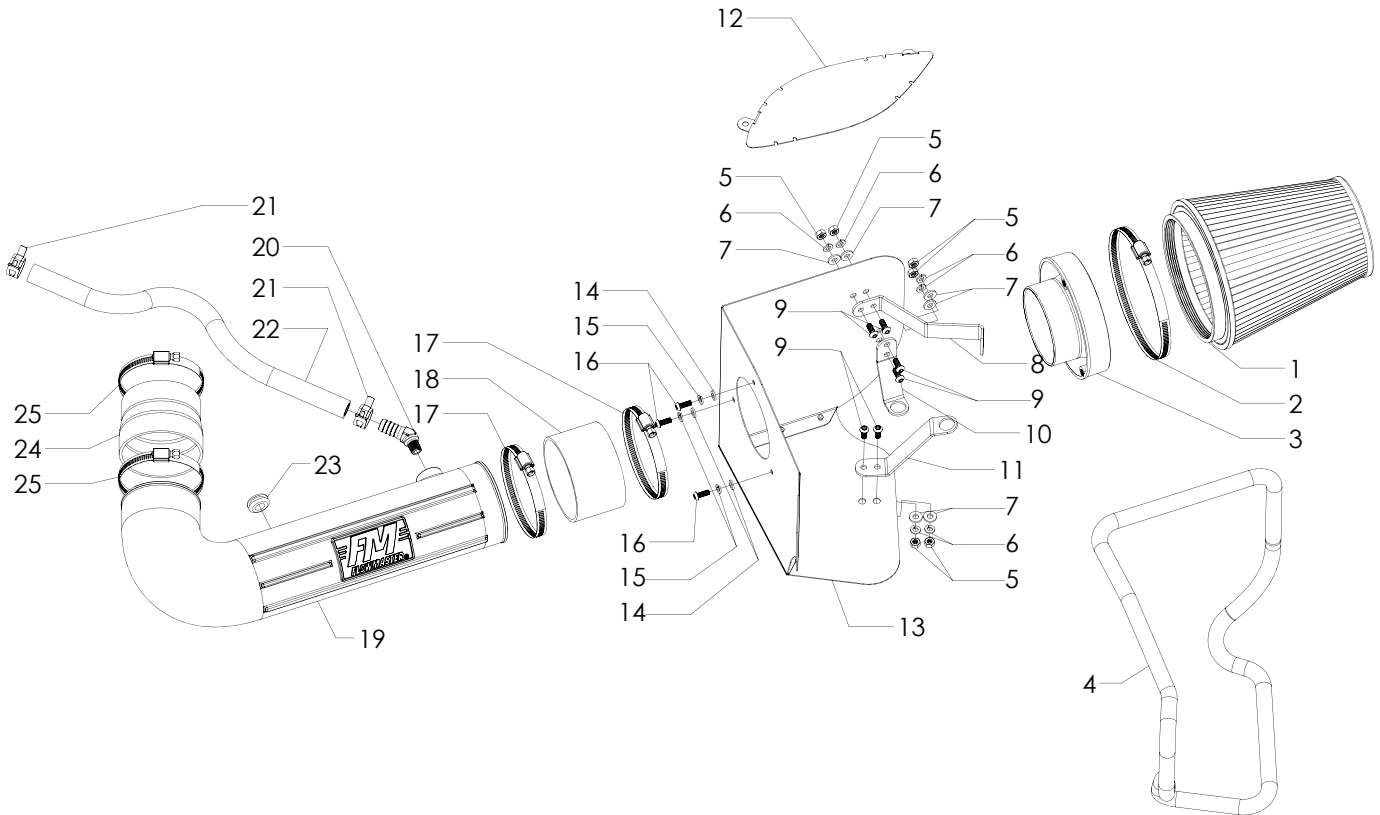

## Installation Instructions

# 615182

SEE CARB APPROVED SPECIFIC APPLICATION IN OVERVIEW SECTION ON PAGE 2.



ITM #	PART #	DESCRIPTION	QTY.
1	AF1001	8 $\frac{5}{8}$ " x 6" Dia. Air Filter	1
2		#104 (4 $\frac{1}{8}$ "-7") Screw Clamp	1
3	AF6002	4" x 6" Air Filter Adapter	1
4	49000061	Heat Shield Gasket	1
5	HW115	$\frac{1}{4}$ "-20 Nut	6
6	HW322	$\frac{1}{4}$ " Lock Washer	6
7	HW320	$\frac{1}{4}$ " Flat Washer	6
8	AF5061	Bracket 1	1
9	HW245	$\frac{1}{4}$ "-20 x $\frac{5}{8}$ " Screw	6
10	AF5078	Bracket 3	1
11	AF5079	Bracket 4	1
12	AF5051	Intake Block-Off Plate	1
13	AF3058	Airbox-Complete	1

ITM #	PART #	DESCRIPTION	QTY.
14	HW319	M6 Flat Washer	3
15	HW318	M6 Split Lock Washer	3
16	HW244	M6 x 1.0 x 16MM Screw	3
17	MC400H	#64 (3 $\frac{3}{16}$ " to 4 $\frac{1}{2}$ ") Screw Clamp	2
18	AF4050	4" IDx2- $\frac{1}{2}$ " L Straight Coupler	1
19	AF2071	Intake Tube	1
20	AF4041	$\frac{5}{8}$ " Barb $\frac{1}{4}$ " Male 45° Elbow	1
21	MC004P	$\frac{5}{8}$ " Hose Pinch Clamp	2
22	49000068	$\frac{5}{8}$ " I.D. Hose	1
23	AF4008	1 $\frac{1}{16}$ " x $\frac{1}{2}$ " ID x $\frac{3}{16}$ " Grommet	1
24	AF4072	3 $\frac{3}{4}$ "-3 $\frac{1}{2}$ " IDx3"L Reduc. Coupler	1
25	MC350H	#56 (3 $\frac{3}{16}$ "-4") Screw Clamp	2
26	LB698-17	CARB EO Label (D-698-17)	1

## OVERVIEW:



### 2011-20 DODGE DURANGO & JEEP GRAND CHEROKEE, 5.7L ENGINE

This product has been granted CARB EO D-698-17 for the above applications.



### 2021-26 DODGE DURANGO & JEEP GRAND CHEROKEE, 5.7L ENGINE

The above applications are legal under the provisions of EPA's Tampering Policy dated November 23rd, 2020. The company has reasonable basis (test results) to verify that this product allows the vehicle to operate within legal emissions standards and is therefore legal to be sold for on-street use in all states that accept the legal provisions of the Clean Air Act and the EPA Tampering Policy. This product is **NOT LEGAL FOR SALE OR USE IN THE STATE OF CALIFORNIA**. Testing with the California Air Resources Board, in order to achieve 50-state compliance, is pending with CARB. Once testing is complete with California, and an E.O. number is issued, this product will be updated to 50-state legal status.



1. Take a moment to read and understand these instructions before beginning install.
2. Turn off ignition and disconnect negative battery cable. **Failure to do this may cause CHECK ENGINE light to illuminate once air intake kit is installed.**



3. Remove and retain engine cover for later re-use.

## REMOVE FACTORY AIR INTAKE SYSTEM:

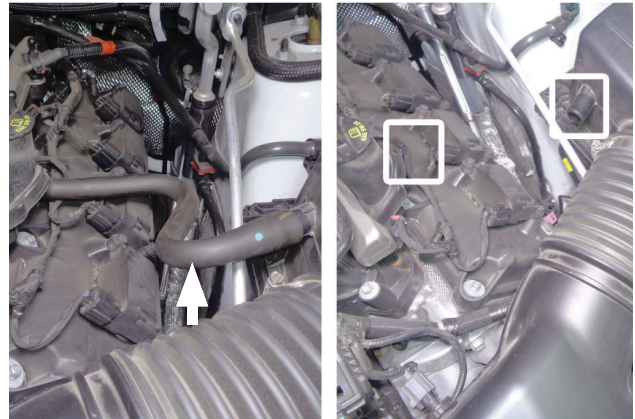

4. Disconnect PCV hose from oil fill and airbox then remove it from engine compartment.



5. Unplug connector from IAT sensor on intake tube.



6. Loosen screw clamp then disconnect intake tube from airbox.

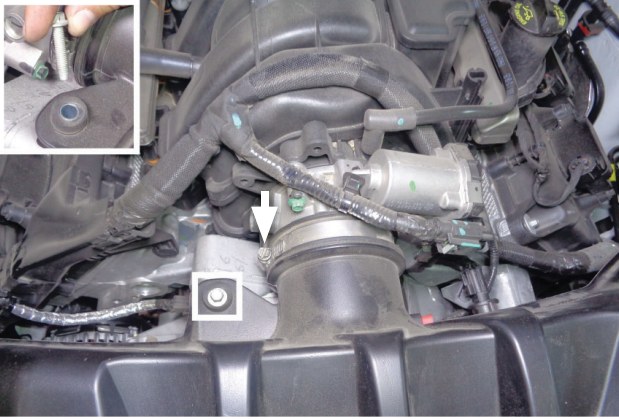

7. Loosen screw clamp holding resonator to throttle body then remove screw on resonator.



8. Remove resonator from engine compartment.



9. Remove IAT sensor from resonator, remove o-ring from IAT sensor then retain sensor for re-use.



10. Unclip trim seal from corner of inlet duct.



11. Pull airbox up sharply to release it from its mount grommets then remove it from engine compartment.

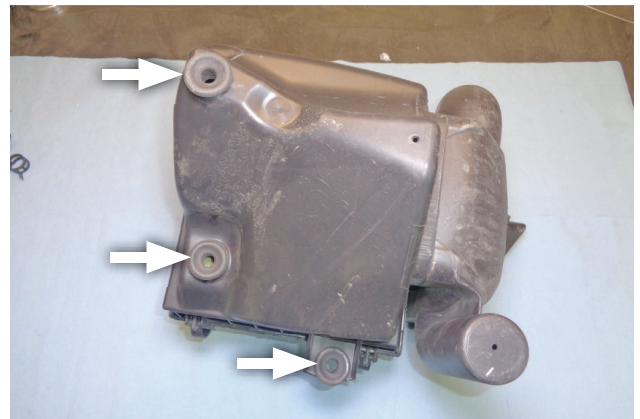

12. Remove 2 of the 3 grommets from bottom of airbox and retain for re-use.

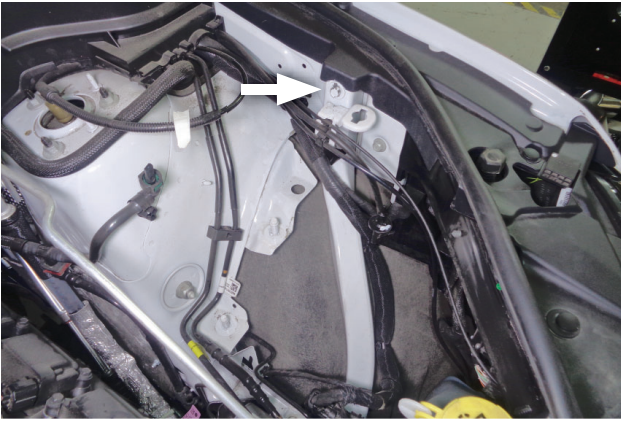

13. Remove bolt indicated from vehicle and retain for re-use.

**ASSEMBLE AND INSTALL FLOWMASTER PERFORMANCE AIR INTAKE SYSTEM:**

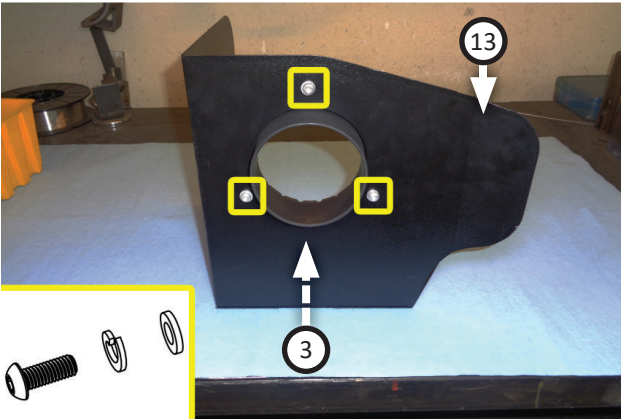

14. Secure air filter adapter (3) to heat shield (13) using screws (16), lock washers (15) and flat washers (14).

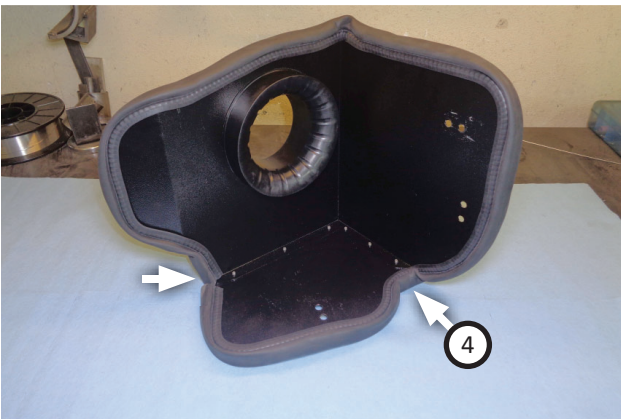

15. Starting at corner indicated, press heat shield gasket (4) gradually around edge of heat shield then trim to fit.

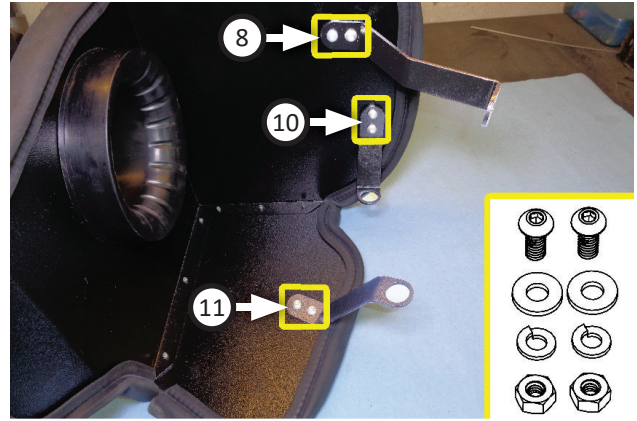

16. Attach brackets (8, 10, 11) to heat shield using screws (9) on bracket side through flat washers (7), lock washers (6) and nuts (5) on heat shield side.

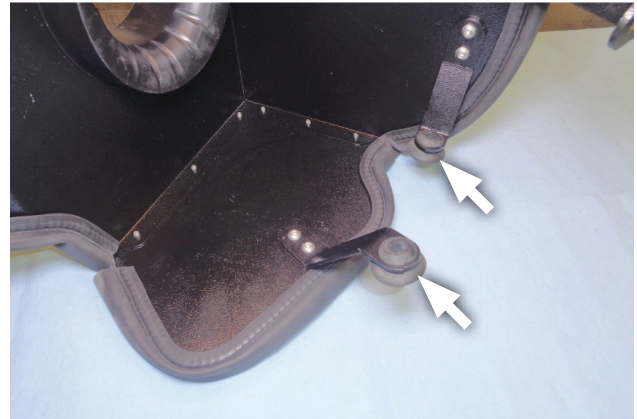

17. Push grommets (x2) (removed step 12) into brackets as shown.

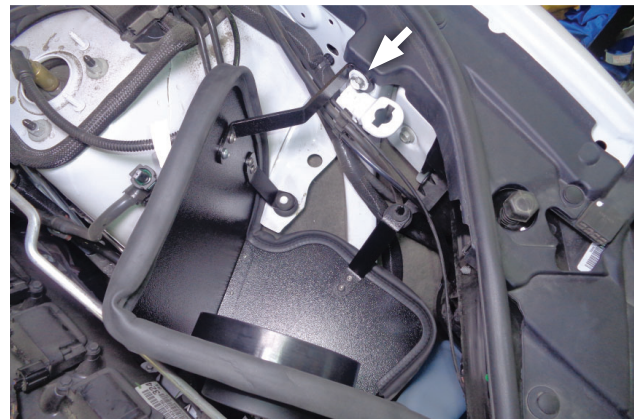

18. Install assembled heat shield into vehicle by pushing grommets (x2) onto pins. Re-install stock bolt (removed step 13) onto vehicle mount through bracket.

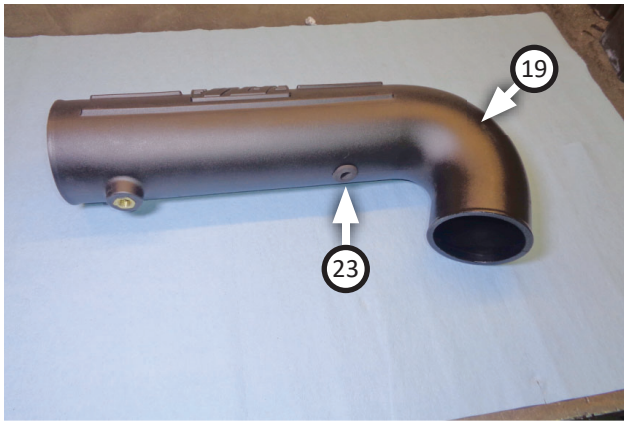

19. Insert **grommet (23)** into **intake tube (19)**.  
Moistening grommet with soapy water will ease insertion.

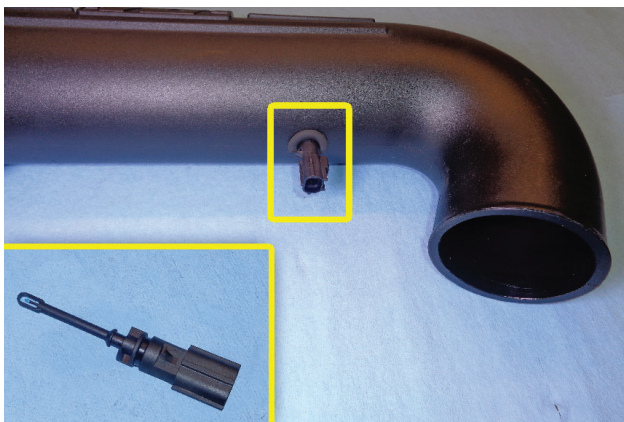

20. Insert IAT sensor (removed step 9) into intake tube at grommet oriented as shown.

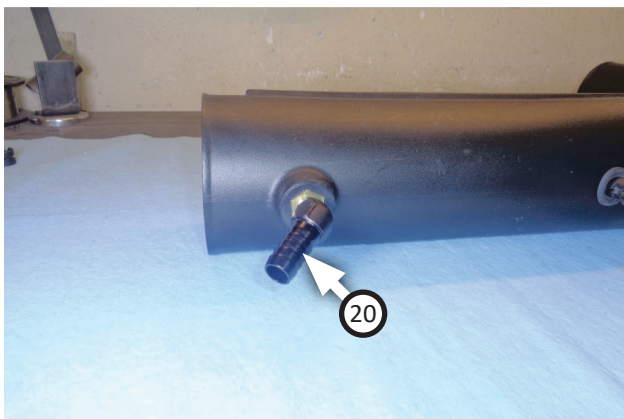

21. Apply 2 wraps of nylon thread tape to threads of **barbed elbow (20)** then install it into intake tube.

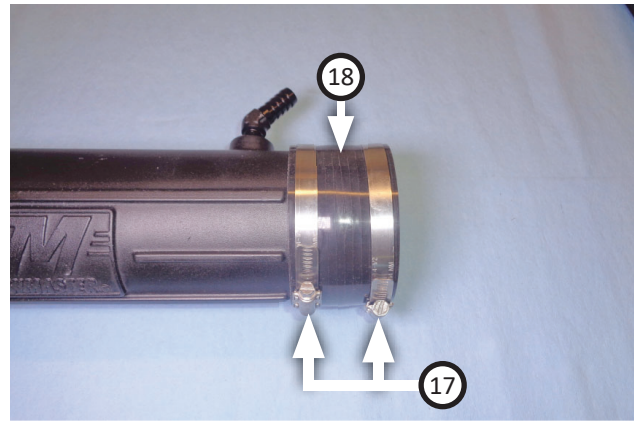

22. Fit **straight coupler (18)** and (x2) **screw clamps (17)** onto filter end of intake tube.

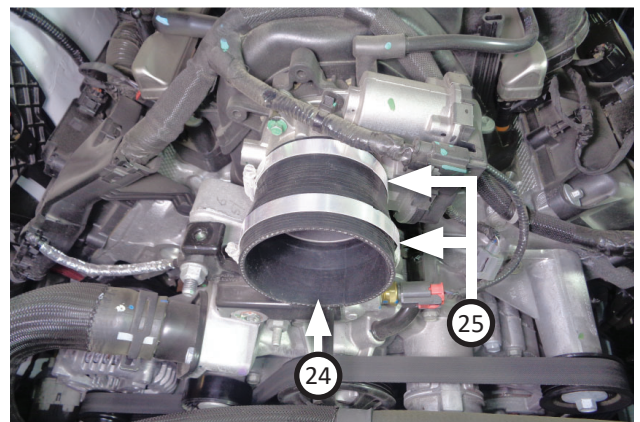

23. Fit tapered end of **reducer coupler (24)** and (x2) **screw clamps (25)** onto throttle body then push coupler fully against stops.



24. Set intake tube into place between heat shield and throttle body as shown without tightening screw clamps.



25. Push couplers flush against heat shield and throttle body before fastening outermost screw clamps (x2). Center intake tube between couplers then tighten remaining screw clamps (x2).



28. Re-install engine cover (removed step 3).



26. Plug connector into IAT sensor on intake tube.



29. Route hose over to barbed elbow then trim to fit.

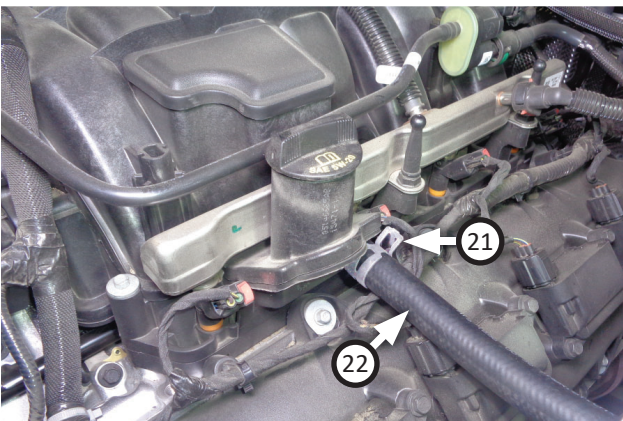

27. Place **pinch clamp (21)** onto **hose (22)** then connect hose to oil fill.

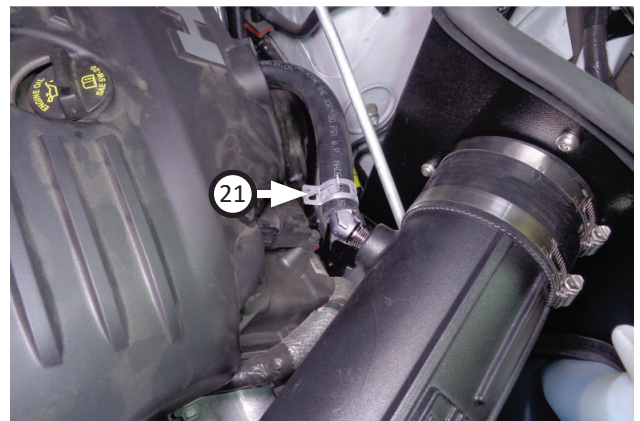

30. Place **pinch clamp (21)** onto loose end of hose then connect hose to barbed elbow on intake tube.

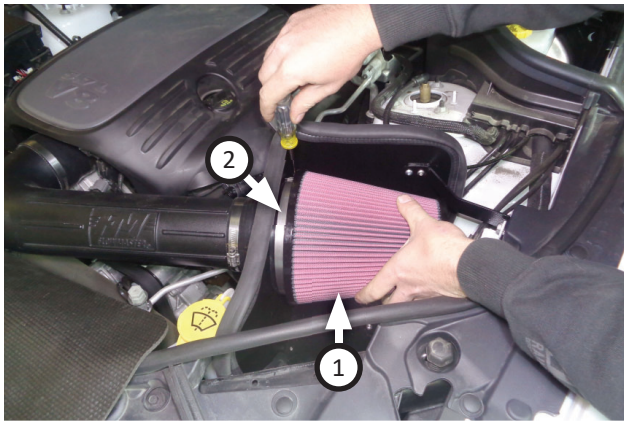

31. Place **screw clamp (2)** on **air filter (1)** then install filter onto adapter and tighten clamp.

**OPTIONAL BLOCK-OFF PLATE INSTALL:**



32. **This step applies only to Durango RT:** Remove screws and vent from underside of hood. Retain for re-use in step 33.



33. **This step applies only to Durango RT:** Re-install vent and **intake block-off plate (12)** in place on hood and secure using screws (removed step 32).

**FLOWMASTER** CARB EO #  
THE PERFORMANCE TECHNOLOGY COMPANY

**DELTA FORCE PERFORMANCE INTAKE**

**D-698-17**

**FLOWMASTER INC. • 866-464-6553**  
 1801 RUSSELLVILLE ROAD, BOWLING GREEN, KY 42101

34. Affix the **CARB EO label (26)** to a clean, readily-visible location under the hood (e.g., near the hood latch), so an inspector can easily see it at emissions testing.



Congratulations, the installation of your FLOWMASTER performance air intake kit is now complete!

**FILTER MAINTENANCE:**

We recommend you clean and oil your air filter at 25,000 mile intervals using Flowmaster's Filter Refresh Kit (PN 615001). Visit our website or your Flowmaster distributor for details.

**FLOWMASTER** INC.  
THE PERFORMANCE TECHNOLOGY COMPANY