

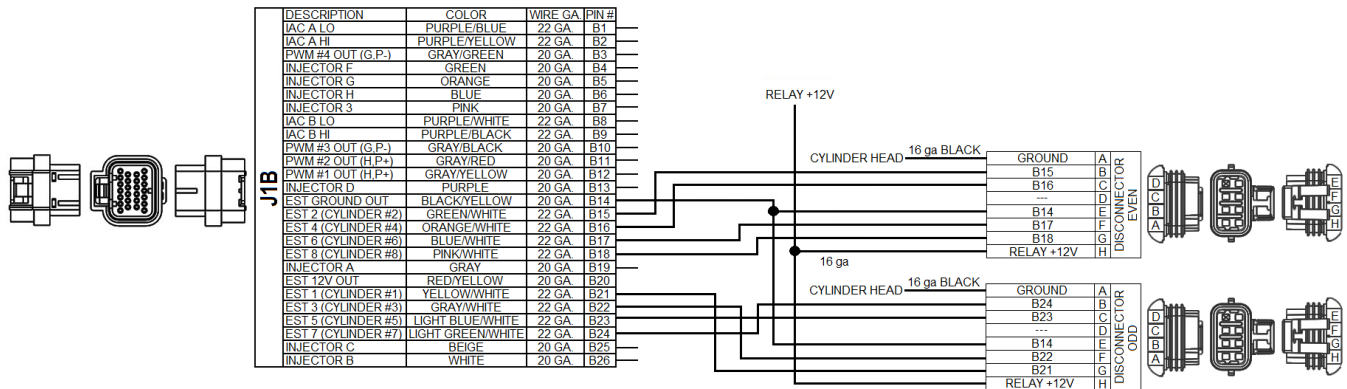

Holley® Universal Coil-On-Plug Ignition Harness P/N 558-307

This harness is designed to install Coil-On-Plug/Coil-Near-Plug (COP/CNP) coils on a Holley® EFI system that has a main wiring harness that does not contain COP trigger wires. The connectors included in this kit are specifically designed to plug into Holley® Smart Coil Ignition sub harness (P/N 558-312) or factory GM LSx coil harnesses which are not included. (GM P/N 12579355 - 2 required).

Pinout (for Odd/Even Banked V8 Engines, such as GM, Chrysler)



“DIS Connector Even”

Connect the terminated metripak end to the Holley® or GM coil harness. The other end is pre-terminated with ECU pins. If you would like to shorten this, extra pins are in the kit for both the ECU and metripak end (re-crimp whatever end you have proper crimpers for). Make sure crimps are done properly.

These Holley® coil harnesses can be installed “backwards” causing an engine misfire. Using the wiring information below, make sure the coil trigger wires for each cylinder are installed in their proper pin location at the J1B connector.

- A – Cylinder Head Ground. This wire should be as short as possible and be solidly attached to the cylinder head of the coils it is attached to. Ground this ONLY to the cylinder head, nowhere else.
- B – ECU J1 – B15 – Cylinder #2 Coil Trigger
- C – ECU J1 – B16 – Cylinder #4 Coil Trigger
- D – Blank
- E – ECU J1 – B14 – EST Signal Ground Out (Tie to DIS Connector Odd wire)
- F – ECU J1 – B17 – Cylinder #6 Coil Trigger
- G – ECU J1 – B18 – Cylinder #8 Coil Trigger
- H – Tie to red 14 gauge fused wire and connect to switched power that can properly supply 20 Amps, preferably a relay. Note: Relay must be triggered by RPM activated output (i.e. Fuel Pump Output). Applying full time power to the coils will cause damage, the coils can only have power when the engine is running.

“DIS Connector Odd”

- A – Cylinder Head Ground. This wire should be as short as possible and be solidly attached to the cylinder head of the coils it is attached to. Ground this ONLY to the cylinder head, nowhere else.
- B – ECU J1 – B24 – Cylinder #7
- C – ECU J1 – B23 – Cylinder #5
- D – Blank
- E – ECU J1 – B14 – EST Signal Ground Out (Tie to DIS Connector Even wire)
- F – ECU J1 – B22 – Cylinder #3 Coil Trigger
- G – ECU J1 – B21 – Cylinder #1 Coil Trigger
- H – Tie to red 14 gauge fused wire and connect to switched power that can properly supply 20 Amps, preferably a relay. Note: Relay must be triggered by RPM activated output (i.e. Fuel Pump Output). Applying full time power to the coils will cause damage, the coils can only have power when the engine is running.

Pinout (for Ford Engines or other V8 engines with 1-2-3-4 and 5-6-7-8 cylinder banks)

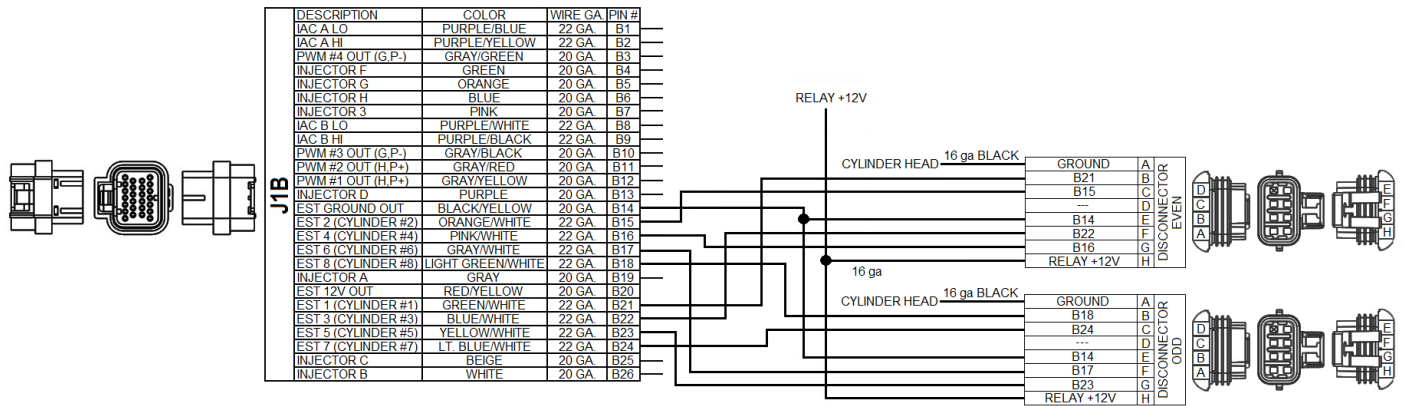

DIS Connector Even

- A – Cylinder Head Ground. This wire should be as short as possible and be solidly attached to the cylinder head of the coils it is attached to. Ground this ONLY to the cylinder head, nowhere else.
- B – ECU J1 – B21 – Cylinder #1 Coil Trigger
- C – ECU J1 – B15 – Cylinder #2 Coil Trigger
- D – Blank
- E – ECU J1 – B14 – EST Signal Ground Out (Tie to DIS Connector Odd wire)
- F – ECU J1 – B22 – Cylinder #3 Coil Trigger
- G – ECU J1 – B16 – Cylinder #4 Coil Trigger
- H – Tie to red 14 gauge fused wire and connect to switched power that can properly supply 20 Amps, preferably a relay. Note: Relay must be triggered by RPM activated output (i.e. Fuel Pump Output). Applying full time power to the coils will cause damage, the coils can only have power when the engine is running.

DIS Connector Odd

- A – Cylinder Head Ground. This wire should be as short as possible and be solidly attached to the cylinder head of the coils it is attached to. Ground this ONLY to the cylinder head, nowhere else.
- B – ECU J1 – B18 – Cylinder #8 Coil Trigger
- C – ECU J1 – B24 – Cylinder #7 Coil Trigger
- D – Blank
- E – ECU J1 – B14 – EST Signal Ground Out (Tie to DIS Connector Even wire)

F – ECU J1 – B17 – Cylinder #6 Coil Trigger

G – ECU J1 – B23 – Cylinder #5 Coil Trigger

H – Tie to red 14 gauge fused wire and connect to switched power that can properly supply 20 Amps, preferably a relay. Note: Relay must be triggered by RPM activated output (i.e. Fuel Pump Output). Applying full time power to the coils will cause damage, the coils can only have power when the engine is running.

Software Setup

Assuming the engine application is not a factory GM 58x or 24x crankshaft reluctor engine, the Crank and Cam sensor types will have to be set up with an Ignition Type of “Custom”. When running individual coils, you must have one of the following:

- “Missing Tooth” crank trigger (60-2 or 36-1) – If a cam sensor is not used, the coils will have to be fired in a waste fire mode (fire both on compression and exhaust strokes). If a cam sensor is present, the coils can be fired only on the compression stroke.
- “1 pulse/fire” – If the crank is a typical 4x trigger on a V8, there is no identification in the crank signal about which cylinder is number one. Hence, a 1 pulse/fire setup requires and depends on a cam sensor signal to identify cylinder number one.

See the “Crank and Cam Sensor” setup in the Holley EFI help instructions on properly setting up the positions of the crank and cam sensors.

The following is recommended Dwell times for various GM coil PN’s:

Most coils can be set to a dwell time of 5.0 msec. Below are recommendations for various factory GM LS coils based upon Holley testing:

The following coil should be set to a maximum of 5.0 msec:

- 10457730

The following coil should be set to a maximum of 4.5 msec. A Value greater than this may cause the coil to fire prematurely resulting in overly advanced ignition timing:

- 19005218

The following coils should be set to a maximum of 3.5 msec:

- 12573190
- 12611424
- 12570616

NOTE: If using the Holley® Smart Coils (P/N 556-112), please refer to the instruction sheet provided with them for recommended dwell times.

**Holley® Performance Products
1801 Russellville Road
Bowling Green, KY 42101**

**1-270-781-9741
1-866-464-6553
www.holley.com**

© 2025 Holley Performance Products, Inc. All rights reserved.

**199R10515
Revision Date: 8-21-25**