



GM F-Body LS Swap Engine Mounting Brackets P/N 12512HKR (1970-74) & P/N 12613HKR (1975-81)

Thank you for choosing to use Hooker Blackheart engine swap mounting brackets as part of your engine/transmission swap project. These Hooker Blackheart mounting brackets are part of the most comprehensively engineered system of mounting components, headers and exhaust systems available for this application. The entire Hooker Blackheart swap system is designed to decrease your total swap installation effort and cost, while increasing the engineered quality of your vehicle and compatibility of these components with other popular aftermarket components.



IMPORTANT DESIGN AND INSTALLATION INFORMATION:

YEAR RANGE	MODEL	PART #	USES TEMPLATE?	NOTES
1970-1972	Camaro	12512HKR	Yes	This part number includes a template and only this year range Camaro uses the template
1970-1972	Firebird	12512HKR	Yes	This part number includes a template and only this year range Firebird uses the template
1973-1974	Camaro	12512HKR	No	Highly recommended that new clamshell mounts be installed
1973-1974	Firebird	12512HKR	No	Highly recommended that new clamshell mounts be installed
1975-1981	Camaro	12613HKR	No (Not Included)	Highly recommended that new clamshell mounts be installed
1975-1981	Firebird	12613HKR	No (Not Included)	Highly recommended that new clamshell mounts be installed

These brackets are designed to be used in conjunction with stock OE clamshell style engine mounts, as installed on all 1972-81 Camaro vehicles (Anchor brand P/N 2292 stock rubber replacement clamshell mounts, or Hooker/Holley 71221004HKR clamshell mount cages and 71221014HKR / 71221015HKR poly inserts are recommended). Installation of the 12512HKR brackets into early model 2nd-gen F-body vehicles that were not factory equipped with clamshell mounts requires drilling holes into your vehicle's sub-frame and may require the engine to be hoisted into and out of the vehicle a few of times to verify parts fitment before final installation of the engine.

A drilling template is provided with P/N 12512HKR to properly install the clamshell mounts on 1970-1972 pre-clamshell Camaro vehicles. Installation of 12512HKR brackets on early pre-clamshell Firebird applications will also require drilling, but will use the clamshell mounts themselves as a drilling template to locate one new hole for each mount. The clamshell mounts themselves, and the long coupler bolts (7/16" x 5-1/4") and nuts (7/16") used to secure them to the Hooker Blackheart brackets are not included with these kits and will need to be purchased separately. In order to achieve the intended fitment and clearances of these components, it is highly recommended that new clamshell mounts be installed at the time of installation on 1975-81 cars and is REQUIRED on 1970 and 1972 model year vehicles that were not originally equipped with clamshell mounts.

The combined use of these mounting brackets and related Hooker Blackheart transmission swap crossmembers will allow installation of an LS engine with an 4L60/4L65/4L70/4L70 automatic or TREMEC® LS F-body/GTO T56 transmission into this application without requiring any cutting or hammering to the vehicle body with the exception of the hole for a manual shifter. Installation of a TREMEC® aftermarket T56 Magnum transmission may require floor modifications due to its larger physical size.

Unlike the stock small-block and big-block engine mounting brackets used by GM on 2nd-gen F-bodies, the designed geometry of these engine swap mounting brackets align the engine crankshaft and transmission output shaft axis just off the center-line of the chassis like stock small-block equipped 1st-gen F-body/1968-74 Nova (3rd Gen X-body) vehicles.

Related Hooker Blackheart transmission swap crossmembers share the same chassis-centered geometry of these engine mounting brackets to provide an optimized 3° to 3.5° engine/transmission inclination angle, which is the key to providing minimized U-joint working angles that are desired for lowered, performance/competition vehicles.

With these components installed, your driveline will be purposely configured with compound U-joint angles due to the close-to-center engine/transmission and the stock pinion offset of your rear differential (just like the previously mentioned stock 1st-gen Camaro/68-74 Nova). If you wish to check your U-joint working angles, you merely need to sum together the calculated horizontal angular offset of your driveline (half a degree as designed by Hooker Blackheart engineering) and the typical measured vertical angles of your driveline components. Detailed information on how to measure and calculate single plane and compound U-joint working angles is available from Spicer by going to www.spicerparts.com and search for publication number J3311-1-DSSP.

Due to the exclusive geometry designed into these Hooker Blackheart engine swap mounting brackets, attempts to install headers and/or transmission crossmembers other than those developed by Hooker Blackheart engineering will not be successful.

An engine hoist will be required to position the engine/trans into the vehicle in its proper orientation. Use of an angle-adjustable engine sling will greatly ease the hoisting/loading operation and negate the possible need to reposition the lifting chains mid-operation. An automotive lift or a jack and jack stands will be required to safely raise and support the vehicle.

CAUTION! WORK ONLY ON A LEVEL SURFACE. USE JACKS /JACK STANDS OF SUFFICIENT CAPACITY TO LIFT AND SUPPORT YOUR VEHICLE. NEVER WORK UNDER A VEHICLE SUPPORTED BY A FLOOR OR BUMPER JACK.

COMPATIBILITY:

These engine swap mounting brackets were specifically designed for bolt-in compatibility with Hooker Blackheart transmission swap crossmembers, cast iron LS exhaust manifolds, headers and exhaust systems, and Holley® LS oil pan and accessory drive components for this application.

Oil pans that are directly installable with these mounts include the Holley® **302-1, 302-2, and 302-3** LS retrofit pans, the stock F-body pan and various aftermarket fabricated steel pans.

The F-body, GTO and Corvette accessory drives are compatible with these mounts with the following exclusions:

- The stock plastic shroud on rear of the F-body alternator will have to be heavily modified or removed completely. GTO alternators will need to be swapped to an F-body unit to clear the steering box Pitman arm.
- 1970-74 vehicles will need to adopt the use of an offset Pitman arm, center link and inner tie rod ends from a 1979 Trans Am to allow installation and use of a low-mount F-body alternator.
- Corvette power steering pump pulley will likely need to be swapped for a smaller diameter pulley/pump to clear the upper control arm.
- Stock low-mount A/C compressors are not compatible with these mounts. The compressor must be upper-mounted to the right cylinder head with the use of a Holley® **20-133** (GM R4), **20-134** (Sanden SD508 or SD7), or similar bracket assembly.

If desired, a Holley® **20-135** upper-mounted Corvette style alternator/power steering bracket can be installed (swap to smaller diameter power steering pump pulley recommended for upper A-arm clearance) and is compatible with all F-body/GTO, Corvette and truck balancer/water pump offsets with the use of the following Holley® bracket spacer kits: Corvette - **21-1**, F-body/GTO - **21-2**, and Chevy/GMC truck/2010-up Camaro - **21-3**.

Two additional complete accessory drive bracket kits are available that include both the A/C and alternator/power steering brackets listed above. These kits are part numbers **20-131** (GM R4 compressor) and **20-132** (Sanden SD508 or SD7 compressor).

Hooker™ LS swap manifolds (**8501HKR**) and Hooker Blackheart long-tube headers (**70101311-RHKR/70101312-RHKR**) will all allow the use of the stock A/C evaporator case on the firewall when installed with these Hooker Blackheart LS engine swap mounting brackets.

The engine position obtained with these brackets is compatible with both the standard and optional hide-away windshield wiper motors mounted on the firewall.

More LS engine performance components, such as EFI fuel control systems, fuel filters, fuel pumps, plumbing hose/fittings and valve covers can be found at www.holley.com.

TIPS FOR A SUCCESSFUL ENGINE SWAP:

1. Check that the hardware package includes the following: (8) M10 x 1.5 x 30 Bolts, (8) 3/8"-16 x 1" bolts (**12512HKR only**), and (8) 3/8-16 flanged nuts (**12512HKR only**). If these are missing, please contact Technical Service at 1-866-464-6553 or 270-781-9741.
2. Mark all hoses, wires, and vacuum lines, according to their function. Use masking tape and a pen for this.
3. Whenever possible, utilize the existing wiring and lines.
4. Get a wiring diagram of your vehicle and one for the vehicle from which the new motor was removed. Make photocopies of both systems. Add your modifications to these copies, so you will have accurate records for future reference.
5. Think carefully before removing or defeating any emissions device. A legal engine swap requires the emissions components to be intact, especially when you try to sell the vehicle.
6. Save as much hardware that is removed from the donor engine as possible. You may need some of these items later.
7. Taking the time to do it right is cheaper than taking short cuts and having to do it again. Make sure you pay close attention to critical areas like fuel systems and brake lines. Neglecting to double-check your work could have life or death consequences.
8. Do not overstress components that are designed for stock four or six cylinder engine torque by over-abusing a motor of greater horsepower.
9. Don't forget to upgrade your radiator, fan(s), and hoses to accommodate the cooling requirements of your LS engine.

VEHICLE PREP:

1. Remove the hood from the vehicle.
2. Disconnect the battery and fuel lines.
3. Remove the existing wiring harness and set aside for later re-use of connectors, as needed, to complete electrical connections to the swap engine harness.
4. Drain all coolant and remove the radiator/hoses from vehicle.
5. Remove the driveshaft, engine, transmission and related mounts from the vehicle.

SWAP ENGINE/TRANS PREP:

1. Carefully remove the following components from the engine: spark plug wires, exhaust manifolds/O2 sensors, wiring harness/computer, MAF sensor, starter motor/plate and dust covers, A/C compressor and bracket, the oil dipstick/tube, and motor mounts.
2. Clean and paint parts to be re-used, if desired.
3. Secure engine/trans assembly to lifting sling and engine hoist.

ENGINE INSTALL:

FOR INSTALLING 12512HKR BRACKETS ON PRE-CLAMSHELL VEHICLES:

Camaro applications-

1. Remove the factory engine frame stands (brackets to which engine mounts are attached) from the sub-frame. Next, align the included drilling template with the existing holes in either side of the sub-frame following **Figure 1** on the next page and pilot drill two 3/16" diameter holes in each side of the sub-frame in the positions indicated by the template. Use 3/8" bolts as guide pins in the template "align" holes to keep it in position as you drill.
2. Rotate and flip the template to align it with the opposite side of the sub-frame as shown in the diagram and repeat the pilot drilling process. Next, use a 25/64" drill bit and enlarge all the piloted holes to their final size.
3. Using the holes you just drilled and the top holes used for aligning the template (x4 bolts total each side), attach the clamshells to the sub-frame with the included 3/8" fasteners.

Firebird applications – Remove the factory engine frame stands (brackets to which the engine mounts are attached) and align the top two holes of each clamshell mount or template with the top two holes that were used to attach the frame stands you just removed to the sub-frame. Insert 3/8" bolts into the holes for use as guide pins to hold the alignment. Next, mark the position of the bottom rearward hole of each clamshell onto the sub-frame and drill them out to a final diameter of 25/64".

NOTE: The end of the clamshell mounts with the two wider spaced holes should be at the top of the sub-frame.

FOR INSTALLING 12512HKR AND 12613HKR BRACKETS ON FACTORY EQUIPPED CLAMSHELL VEHICLES:

1. Remove existing clamshell mounts from the sub-frame and replace them with the aftermarket rubber replacement clamshell mounts, or the Hooker/Holley clamshell mount cages and poly inserts previously mentioned on page 1.

FOR ALL MODELS:

1. Raise and maneuver the engine hoist into position for installing the engine/transmission. In order to be able to lower the assembly into its proper position in the vehicle, the initial position of the sling should provide at least a 45° tilt angle of the engine/transmission.
2. Using the supplied M10 bolts, attach the Hooker Blackheart left and right engine mounting brackets. The large holes in the base plates install towards the rear of the motor.
3. Lift the assembly high enough to clear the radiator support at the front of the car. If your hoist will not go high enough to clear the support, have an assistant lift the end of the transmission up to clear it as you move the hoist under the vehicle.
4. Lower the assembly into the engine compartment, level off, and place onto the clamshell mounts (new mounts recommended).
5. Prop up and support the transmission tail shaft and then install the long coupler bolts through engine bracket ears and mounts. Install purchased nuts onto the bolts and tighten them.

6. If purchased, proceed to installing your Hooker Blackheart transmission swap crossmember and headers per the instructions included with their packaging.

Any questions? Please contact Technical Service: 1-866-464-6553 or 270-781-9741. For online help, please refer to: www.holley.com.

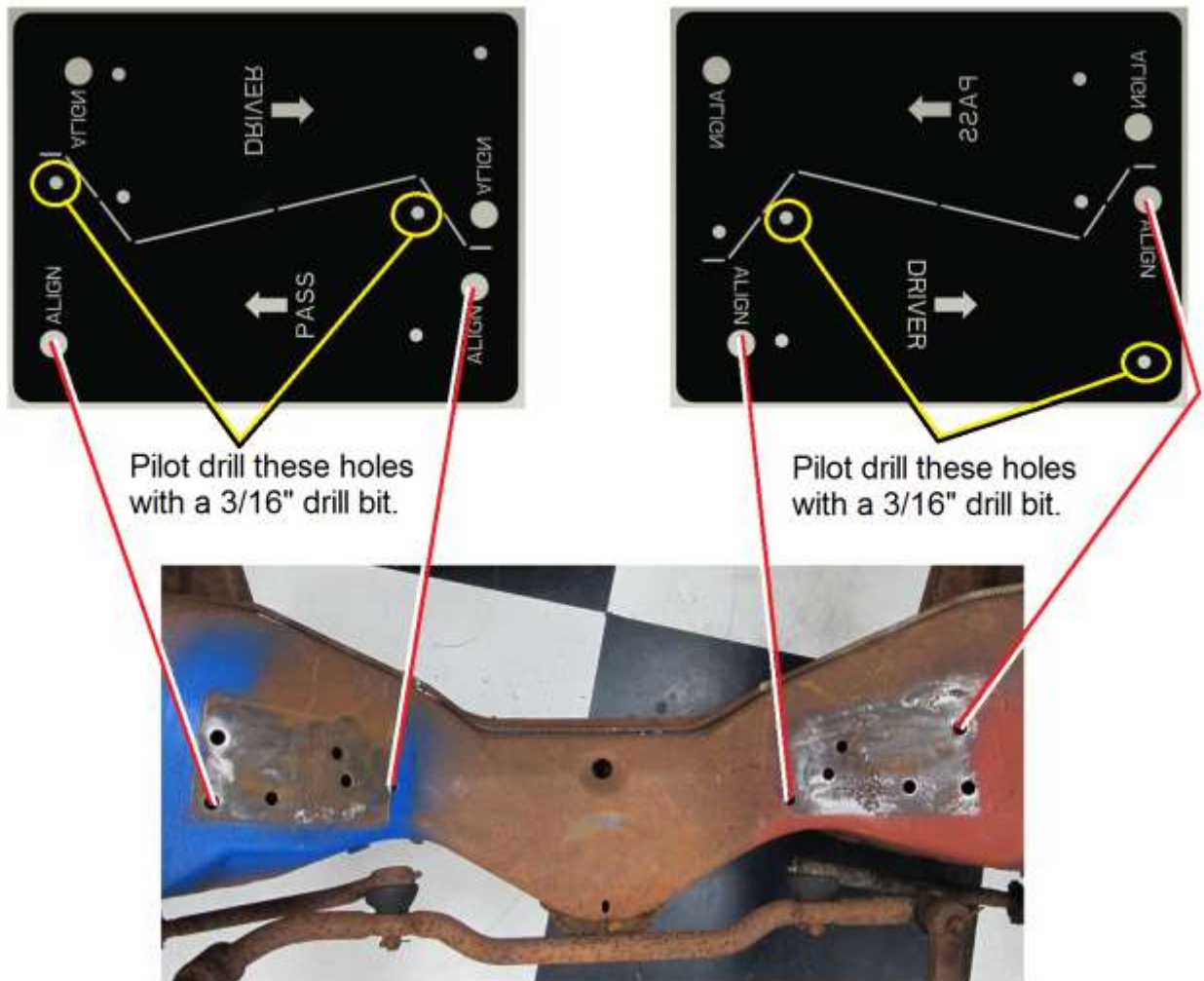

Figure 1

LIMITATION OF LIABILITY – DISCLAIMER:

The regulation of emissions production, noise levels, and safety standards is undertaken by the federal government, each of the fifty state legislatures, and by many local municipalities, towns, and counties. HOOKER™ makes no warranties of merchantability, of fitness for particular purpose, or that its products are approved for general use, or that its products comply with laws, regulations, or ordinances in the state where they may be sold to the ultimate purchaser, the consumer.

Unless expressly stated to the contrary in the catalog, instruction sheet; or price list, the entire risk as to the conformity of any company product in any such state and as to repair should the product prove to be defective or non-conforming, is on the retail purchaser, the buyer, the ultimate consumer, of such product and it is not upon the seller, distributor, or manufacturer.

In this connection, the retail purchaser, the buyer, the ultimate consumer assumes the burden of the entire cost of any and all necessary service, alterations, or repair.

THE FOREGOING STATEMENT LIMITS THE LIABILITY OF THE MANUFACTURER.

California vehicle code, sections 27156 and 38391, prohibits the advertising, offering for sale, or installation of any device, which modifies a vehicle's emission control system, unless exempted, unless otherwise noted. HOOKER™ Headers that have not received an Executive Order (E.O.) exemption from these code sections are not legal for sale or use in California on vehicles originally equipped with catalytic converters, except for racing vehicles, which may never be driven upon a highway. Check with your local authorities to determine if these headers are legal for use in your particular area.

© 2013 Holley Performance Products, Inc. All rights reserved. Tous Droits Réservés.



P/N 12614HKR

1970-81 GM F-Body LS Swap Automatic Transmission Crossmember
(GM 4L60, 4L65, 4L70 and 4L75 transmissions only)

Installation Instructions 199R10649

Thank you for choosing to use this Hooker™ transmission crossmember as part of your engine/transmission swap project. This crossmember is part of the most comprehensively engineered system of mounting components, headers and exhaust systems available for this application. The entire Hooker™ swap system is designed to decrease your total swap installation effort and cost while increasing the engineered quality of your vehicle and compatibility of these components with other popular aftermarket components.



IMPORTANT DESIGN AND INSTALLATION INFORMATION:

This crossmember is designed as part of a fully-engineered LS swap mounting system for 2nd-gen F-body vehicles. It has been CAD designed and FEA validated to provide excellent structural strength and torsional rigidity from its high-strength low-alloy steel construction. As a further benefit to the user, a maximized ground clearance pathway for routing 2.5" or 3" exhaust system tubing is included as a main design feature.

Installation of this crossmember requires the use of a stock GM 4L60/4L65 automatic transmission isolator mount from a 2003 Chevy/GMC truck or 2002 Camaro vehicle, or an aftermarket Prothane™ 7-1604 polyurethane mount or one of equivalent installed height.

Due to its unique design geometry, this crossmember must be installed in conjunction with Hooker™ 1970-74 or 1975-81 F-body LS swap engine mounting brackets to provide proper driveline operation angles and allow installation of an LS engine and 4L60/4L65/4L70/4L75 automatic transmission into this application without requiring any cutting or hammering of the vehicle body.

The related Hooker™ engine mounting brackets share the same chassis-centered geometry of this crossmember to provide an optimized 3° to 3.5° engine/transmission inclination angle that is critical to providing the minimized U-joint working angles that are desired for lowered performance and competition vehicles.

The installed geometry of this crossmember and the compatible Hooker™ engine mounting brackets align the engine crankshaft and transmission output shaft axis with the center line of the chassis, like most pro-built cars and aftermarket subframes for 2nd-gen F-bodies (like DSE for example).

With these components installed, your driveline will be purposely configured with compound U-joint angles, due to the centered engine/transmission and the stock pinion offset of your rear differential (like the previously mentioned pro-built cars and aftermarket subframes for 2nd-gen F-bodies). If you wish to check your U-joint working angles you merely need to sum together the calculated horizontal angular offset of your driveline (half a degree as designed by Hooker™) and the typical measured vertical angles of your driveline components. Detailed information on how to measure and calculate single plane and compound U-joint working angles is available from Spicer. Go to www.spicerparts.com and search for publication number J3311-1-DSSP.

A suitable lifting jack or stand will be required to install this crossmember with the appropriate transmissions for which it is intended.

COMPATIBILITY:

This crossmember was specifically designed for compatibility with Hooker engine swap mounts, cast iron LS exhaust manifolds, headers and exhaust systems and Holley® LS oil pan and accessory drive components for this application.

Oil pans that are directly installable with this crossmember include the Holley® **302-1** and **302-2** LS retrofit pan, the stock F-body, and various aftermarket fabricated steel pans.

The F-body, GTO and Corvette accessory drives are all installable with these mounts with the following exclusions:

- GTO alternators will need to be swapped to an F-body unit to clear the steering box pitman arm.
- Corvette power steering pump pulley will likely need to be swapped for a smaller diameter pulley/pump to clear the upper control arm.
- Stock low-mount A/C compressors are not installable with these mounts; compressor must be upper-mounted to right cylinder head with the use of a Holley **20-133** (GM R4), **20-134** (Sanden SD508 or SD7), or similar bracket assembly.

If desired, a Holley® **20-135** upper-mounted Corvette style alternator/power steering bracket can be installed (swap to smaller diameter power steering pump pulley recommended for upper A-arm clearance) and is compatible with all F-body/GTO, Corvette and truck balancer/water pump offsets with the use of the following Holley bracket spacer kits: Corvette - **21-1**, F-body/GTO - **21-2**, and Chevy/GMC truck/2010-up Camaro - **21-3**.

Two additional complete accessory drive bracket kits are available that include both the A/C and alternator/power steering brackets listed above. These kits are part numbers **20-131** (GM R4 compressor) and **20-132** (Sanden SD508 or SD7 compressor).

Hooker™ LS swap manifolds (**8501HKR**), mid-length headers (**2471HKR & 2472HKR**), and long-tube headers (**2295HKR & 2296HKR, 2297HKR and 2298HKR**) are compatible with most stock A/C evaporator cases on the firewall, when installed with this Hooker™ LS engine swap transmission crossmember.

More LS swap/engine performance components, such as EFI fuel control systems, fuel filters, fuel pumps, plumbing hose/fittings and valve covers can be found at www.holley.com.

Due to the unique chassis-centered geometry of its design, this crossmember is not compatible with any type or brand of universal LS engine swap plates, including those produced by Hooker. This crossmember is only compatible with **12512HKR** and **12613HKR** Hooker engine mounting bracket kits.

Use of this crossmember with half-height body bushings is only possible if relief pockets are fabricated into the floor to clear the arched humps of the crossmember and may require further floor clearance operations to clear the transmission bellhousing/case.

INSTALLATION:

Pre-installation notice: In all vehicles, this crossmember is to be installed with its mounting flanges resting in the scalloped pockets formed into the top of the subframe rails. On some earlier vehicles and depending on what transmission you are installing, the factory mounting holes present in the formed pockets will align with the holes in this crossmember and can be used for attachment purposes using two bolts/nuts per side (**Figure 1**). Later vehicles were produced with no holes in this location, which requires installation using the supplied angle brackets under the crossmember to attach the crossmember to the inside walls of the subframe through four drilled holes (**Figure 2**). If you are removing your subframe for any reason, you can also use that opportunity to drill new attachment holes in the top of the subframe and nut access holes in the bottom of the subframe to be able to attach the crossmember as shown in figure 1.



Figure 1

Top surface attachment method to top of subframe



Figure 2

Angle bracket attachment method on inside walls of subframe

This crossmember is designed to provide an exhaust routing path with maximized ground clearance. Be aware that 1970-74 models have floor pans which are lower to the top of the subframe than those of 1975-81 models and require more careful maneuvering of the crossmember into position to reduce the possibility of marring of the underside finish of the floor. Worn or collapsed body bushings will further diminish the available installation space and may require increased force or leverage to be applied to the crossmember to persuade it into proper position. It is highly recommended that new body bushings be installed prior to performing your engine/trans swap.

This crossmember provides geometry that allows the use of two OE rubber isolators (2003 GM truck or 98-2002 Camaro 4L60 isolators) for reduced drivetrain vibration characteristics, or a Prothane™ 7-1604 polyurethane isolator for more positive drive train control. The center slot in the crossmember is sized to accept the smaller stud of the OE rubber truck isolator “as-is” and must be reamed slightly larger to accept the stud size of the Camaro isolator. The slightly more forward outer slots in the crossmember are for attaching the Prothane™ isolator, which requires installation of the supplied two-hole plate spacer between the isolator and the crossmember to compensate for the difference in height between the OE rubber isolators and the Prothane™ polyurethane isolator.

WARNING! Leaving this spacer out, when using the Prothane™ isolator, will increase the engine inclination angle beyond that intended by Hooker™ and decrease the ground clearance of Hooker™ headers designed for this application.

1. Check that the hardware package includes the following:

- (2) Angle Brackets
- (4) 3/8-16 x 1” Flanged Head Bolts
- (4) 3/8” Flanged Nuts
- (4) 7/16-14 x 1” Flanged Head Bolts
- (4) 7/16” Flanged Nuts.

If any are missing, please contact Technical Service at 1-866-464-6553 or 270-781-9741.

2. Raise the tail shaft of the transmission to its highest possible point of lift.

3. Insert either end of the crossmember between the vehicle subframe and floor sheet metal

4. Shift the crossmember over far enough to allow the free hanging end to be pushed up above the height of the subframe then shift the crossmember over to center it on both mounting surfaces of the subframe. Depending on the state of condition of your body bushings, you may need to use a rubber mallet to assist in this effort.

5. If your vehicle is an earlier model with pre-punched factory holes present in the subframe at the location of the crossmember pocket, use the holes present to attach the crossmember with the supplied nuts and bolts and skip to **step 6** now. If there are no such holes in your vehicle subframe, or the ones present do not line up with the holes in the crossmember, complete steps A,B and C below before moving on to step 6.

- A. Connect the crossmember to the transmission using the isolator you intend to use in operation and lower the weight of the transmission onto the crossmember to the point where the crossmember mounting flanges are resting squarely against the mounting surfaces of the subframe
- B. Attach the two supplied angle brackets to the underside of the crossmember and seat each against the side of the frame rail; tighten the brackets against the crossmember and mark the center of all four holes located adjacent to the subframe for the purpose of drilling. Move the brackets and crossmember out of the way, pilot drill, and drill all four holes to 7/16” diameter.
- C. Move the crossmember and angle brackets back to their previous position and attach the brackets to the subframe with the supplied bolts and nuts.

Tip: While working through the open ends of the subframe rails, use a long box end wrench or paint stick with double-sided tape to capture the nuts against the inside of the subframe wall and slide them back into position at the drilled holes.

6. Securely attach the isolator to the transmission with appropriately sized bolts.

7. Attach the isolator to the crossmember with the hardware supplied with the isolator and tighten all fasteners.

Any questions? Please contact Technical Service: 1-866-464-6553 or 270-781-9741. For online help, please refer to: www.holley.com.

LIMITATION OF LIABILITY – DISCLAIMER:

The regulation of emissions production, noise levels, and safety standards is undertaken by the federal government, each of the fifty state legislatures, and by many local municipalities, towns, and counties.

HOOKER™ makes no warranties of merchantability, of fitness for particular purpose, or that its products are approved for general use, or that its products comply with laws, regulations, or ordinances in the state where they may be sold to the ultimate purchaser, the consumer.

Unless expressly stated to the contrary in the catalog, instruction sheet; or price list, the entire risk as to the conformity of any company product in any such state and as to repair should the product prove to be defective or non-conforming, is on the retail purchaser, the buyer, the ultimate consumer, of such product and it is not upon the seller, distributor, or manufacturer.

In this connection, the retail purchaser, the buyer, the ultimate consumer assumes the burden of the entire cost of any and all necessary service, alterations, or repair.

THE FOREGOING STATEMENT LIMITS THE LIABILITY OF THE MANUFACTURER.

California vehicle code, sections 27156 and 38391, prohibits the advertising, offering for sale, or installation of any device, which modifies a vehicle's emission control system, unless exempted, unless otherwise noted. HOOKER™ Headers that have not received an Executive Order (E.O.) exemption from these code sections are not legal for sale or use in California on vehicles originally equipped with catalytic converters, except for racing vehicles, which may never be driven upon a highway. Check with your local authorities to determine if these headers are legal for use in your particular area.



**Transmission Polyurethane Mount - GM
71223029HKR & 71223030HKR
Installation Instructions**

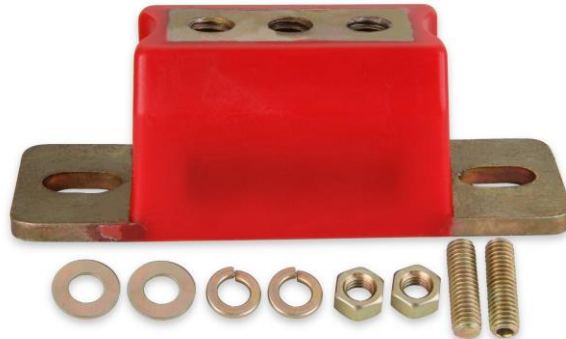

Thank you for choosing to use the Hooker BlackHeart™ transmission mount as part of your performance vehicle project. Please read thoroughly and understand these instructions before attempting installation.

PRE-INSTALLATION CONSIDERATIONS:

These polyurethane transmission mounts may be used as a direct replacement for stock GM rubber mounts that measure 1.75" in height. Replacement of mounts with a greater height than 1.75" can be accommodated with the use of shim washers between the crossmember and the mount.

The polyurethane construction is capable of high horsepower applications while preserving vibration dampening and the safety interlock design of the inner components ensures that even if the polyurethane fails the mount will not separate. These polyurethane mounts are capable of fitting either a one or two stud type of crossmember interface.

BEFORE BEGINNING:

Check that the package contains the following hardware:

71223029HKR	
Qty.	Description
1	Black Polyurethane Transmission Mount
2	7/16"-14 x 1.5" Studs
2	7/16"-14 Hex Nuts
2	Flat Washers
2	Lock Washers

71223030HKR	
Qty.	Description
1	Red Polyurethane Transmission Mount
2	7/16"-14 x 1.5" Studs
2	7/16"-14 Hex Nuts
2	Flat Washers
2	Lock Washers

INSTALLATION:

1. Determine if your application requires a one or two stud crossmember interface. Install the supplied stud(s) (7/16"-14 x 1.5") into the appropriate threaded holes in the polyurethane mount with a 7/32" hex key. If no hex key is available, the studs can also be installed into the mount by "double nutting" the end of the stud with the supplied hex nuts. Install the stud(s) until firmly seated in place.
2. Install the mount onto the crossmember with hardware provided (shown in **Figure 1**). Do not tighten the hex nuts at this time.
3. Install the factory transmission bolts (user supplied). Do not tighten the bolts at this time.
4. Confirm alignment of the polyurethane mount with the transmission and crossmember. Tighten and torque the transmission bolts to factory torque specifications. Also tighten and torque the crossmember hex nut(s) to 49 ft./lbs.

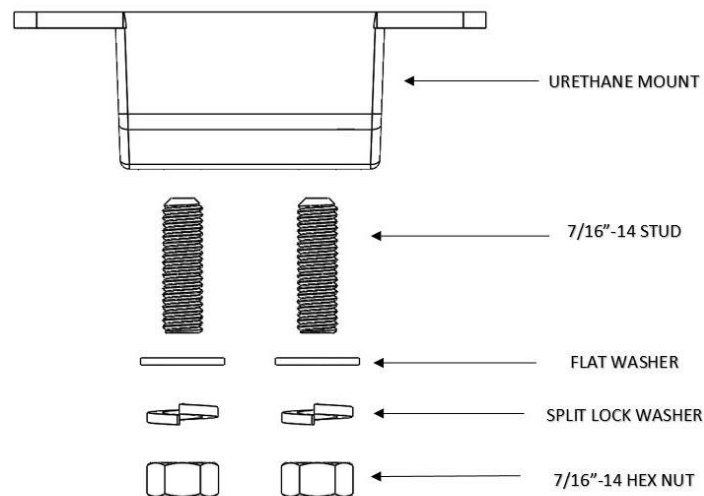

Figure 1

LIMITATION OF LIABILITY – DISCLAIMER:

HOOKER™ BLACKHEART makes no warranties of merchantability, of fitness for particular purpose, or that its products are approved for general use, or that its products comply with laws, regulations, or ordinances in the state where they may be sold to the ultimate purchaser, the consumer.

Unless expressly stated to the contrary in the catalog, instruction sheet, or price list, the entire risk as to the conformity of any company product in any such state and as to repair should the product prove to be defective or non-conforming, is on the retail purchaser, the buyer, the ultimate consumer, of such product and it is not upon the seller, distributor, or manufacturer.

In this connection, the retail purchaser, the buyer, the ultimate consumer assumes the burden of the entire cost of any and all necessary service, alterations, or repair.

© 2018 Hooker Headers, Inc. All rights reserved. Tous Droits Réservés.

199R11754

Date: 1-24-19