



Dodge Charger/Challenger/Magnum + Chrysler 300 SRT8 6.1L Super Street Series Header Installation Instructions



**Thank you for your purchase, we appreciate your business.
If additional assistance is needed, please contact Kooks Headers and Exhaust
Toll free at 1-866-586-KOOK or contact your local dealer.**

- System Layout -

Components to Ship With-

- 1) PY-8026-AL - Header Gasket
- 1) SB-B60071 - Bolt Kit
- 1) K60161 - Dip Stick Spacer

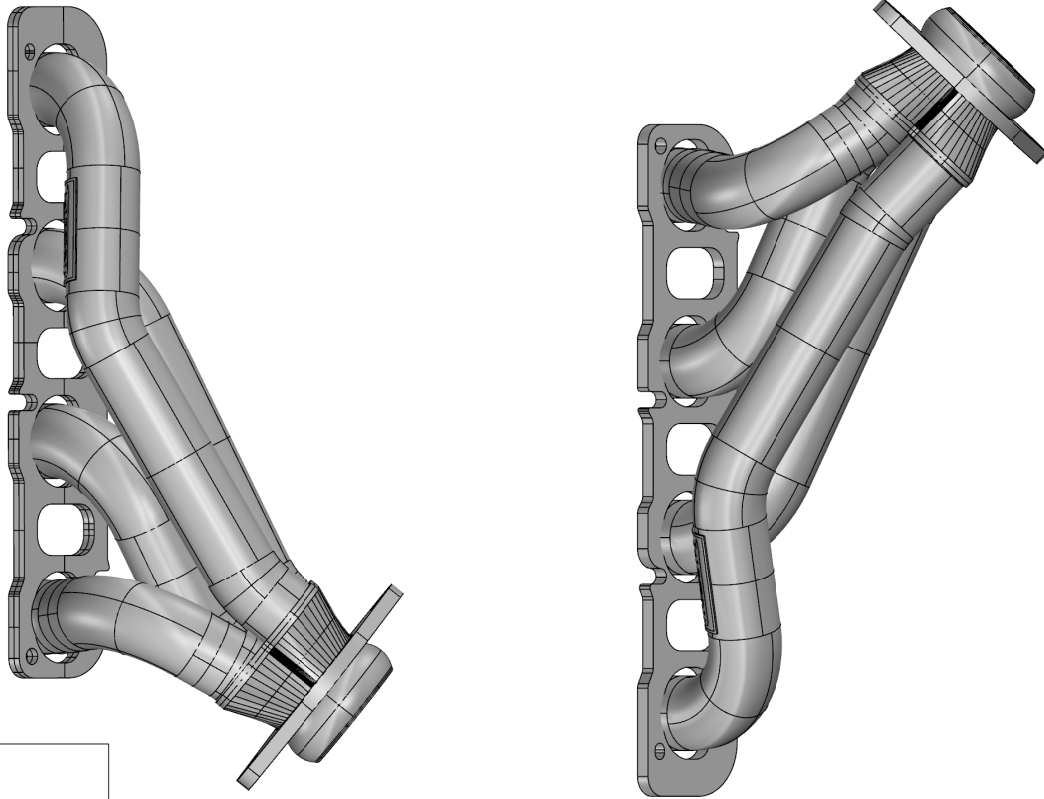

31011400 - 1 7/8"

2006-2010 Dodge Charger SRT8 6.1L
2008-2010 Dodge Challenger SRT8 6.1L
2005-2010 Chrysler 300C SRT8 6.1L
2005-2008 Dodge Magnum SRT8 6.1L



Do not attempt this installation if proper safety equipment is not available to you - seek the assistance of a professional installer

Read and understand all instructions before beginning

Vehicle Preparation

****Raise and Support Vehicle (Refer to Owner's Manual for specified jacking points) ****

Always disconnect the battery before performing this type of work on any vehicle

2 Post Lift Recommended

KOOKS Installation

- Spray penetrating oil on all header bolts and exhaust bolts
- Remove plastic panel under engine attached to the frame
- Unplug O2 sensors after cats, remove catted connections
- Unplug and remove O2 sensors from factory manifold
- Remove dip stick from passenger side
- Remove heat shield from factory manifold (driver side and passenger side)
- Remove factory manifold from engine
- Clean all gasket sealing surfaces
- See drawing below. Install supplied header bolt #1 and #2 in head with about 1/2" of thread sticking out. Install header and gasket by hanging it on the #1 bolt and then swing header up to #2

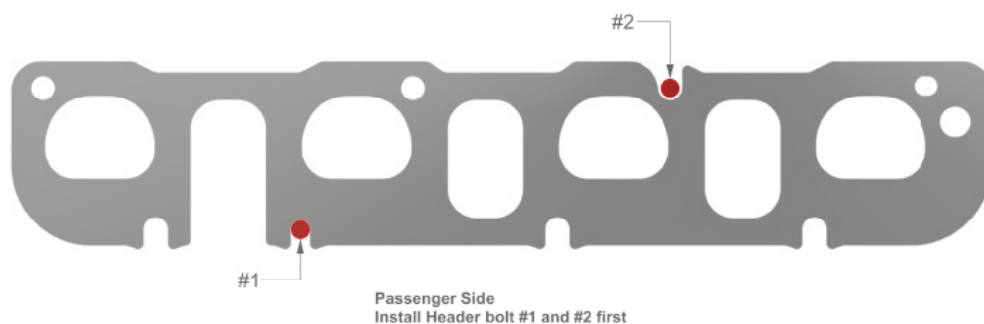
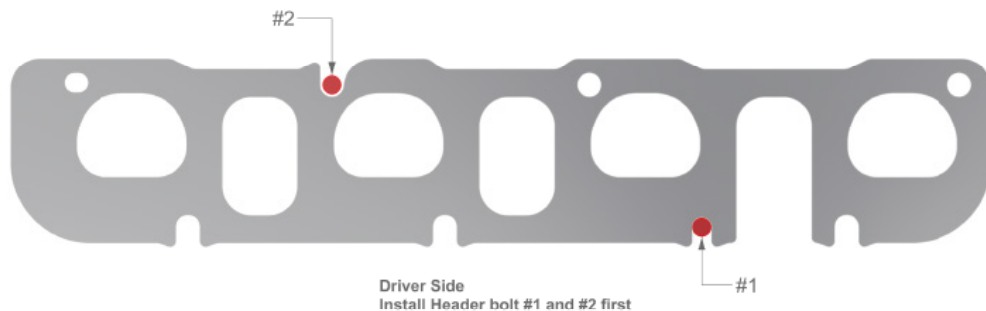

- Install the remaining header bolts. The dip stick is bolted to the passenger side front top bolt. Use the longer header bolt and dipstick spacer to mount dip stick
- Tighten header bolts to OEM torque specs
- Put a dab of anti-seize on threads of O2 sensor, thread sensor into header, do not overtighten. Reconnect O2 sensor to wiring harness
- Install factory catted connections using supplied hardware and reconnect O2 sensors
- Clean all fingerprints/oil/grease from headers
- Start engine and check for exhaust leaks (tighten clamps as needed)
- Allow engine to complete one full heat cycle (heat to operating temp, cool to ambient temp)
- Re-torque all connections

**Thank you for your purchase, we appreciate your business.
If additional assistance is needed, please contact Kooks Headers and Exhaust
Toll free at 1-866-586-KOOK or contact your local dealer.**