

Instructions

Rear Control Arm Bushings

N.B: This instruction sheet should be used in conjunction with the workshop manual and proper safety procedures followed.

Install Guide - page 1 of 2

Application - Dodge Viper
- 1996-2002

(Refer current catalogue for complete listing)

Contents - Bushing 91847 x4
- Bushing 91848 x4
- Bushing 91890 x4
- Bushing 91891 x4
- Steel tube 57mm long x4
- Steel tube 49.5mm long x4
- Stepped washer x16
- Grease

- Raise vehicle evenly and safely support.

Never rely on a Jack only

- Proceed to remove rear wheels

Note - It is recommended only one arm at a time be removed and serviced.

Mark lower eccentrics with texter - this will reduce amount of adjustment required during wheel alignment.

- A 'Bottle Jack' style Press will be required - press out original bushing including steel outer shell. careful to not damage alloy arm.

- Refer page 2 for bushing position

Upper arm



Lower arm
Mark eccentrics prior to removing control arm

N.B: It is recommended that a licenced workshop or tradesperson carry out the above procedure and that workshop manual and relevant safety procedures are followed in addition to the above.

Instructions

Rear Control Arm Bushings

N.B: This instruction sheet should be used in conjunction with the workshop manual and proper safety procedures followed.

Continued - page 2 of 2

- Once old bushings removed, clean eye-ring of and dirt or oil.
- push in new supplied bushings
- refer diagram below for bushing position.

Note stepped washer orientation.

- Grease bushing internal diameter and side face with supplied grease only.

- Bolt arms back up with original hardware. tighten to manufacturers specification.

- Carry out wheel alignment immediately after install.

- Re-check all bolts after 100 miles.

UPPER ARM -

Place bushing 91890 on outer side of arm
Place bushing 91891 on inner side of arm
Use steel tube 49.5mm long

Note stepped washer orientation.

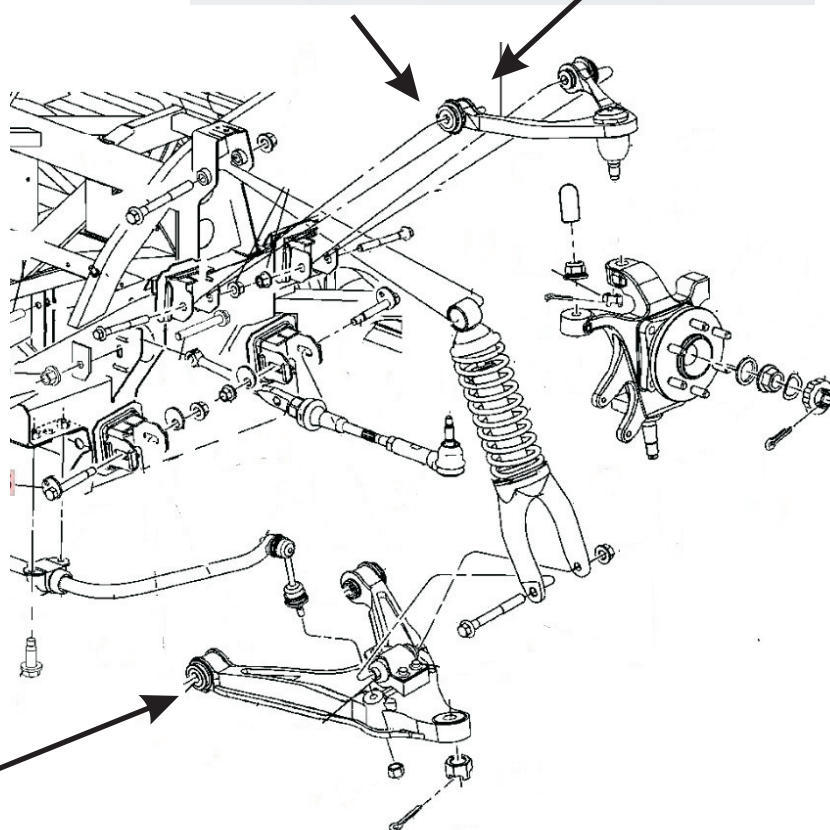
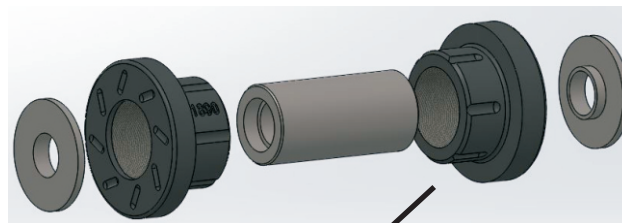

LOWER ARM -

Place bushing 91848 on outer side of arm
Place bushing 91847 on inner side of arm
Use steel tube 57mm long

Note stepped washer orientation.

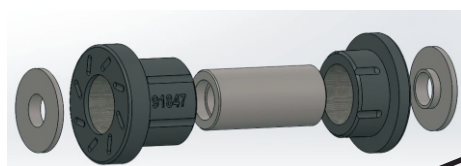

N.B: It is recommended that a licenced workshop or tradesperson carry out the above procedure and that workshop manual and relevant safety procedures are followed in addition to the above.