

Instructions

Engine Mount - Conversion Kit

N.B: This instruction sheet should be used in conjunction with the workshop manual and proper safety procedures followed.

Page 1 of 2

- Raise vehicle evenly and safely support.

Never rely on a Jack only

- Support engine via sump with timber, or hang engine.
- Confirm threads in block are clean.
- Refer diagram below. Re-check all bolts after 100kms travelled.

Application - Early Chev vehicles
- with original 3 bolt mount situation.

Always refer complete catalogue listing

Contents - 3/8 bolts x4
- M10 bolts x6
- M10 bolts counter sunk x2
- Flat washers x10
- Engine flat plates x2
- Engine mounts x2

Counter sunk hole

- use counter sunk bolts
- tighten to 40-45Nm

Bolt engine mount
over plate

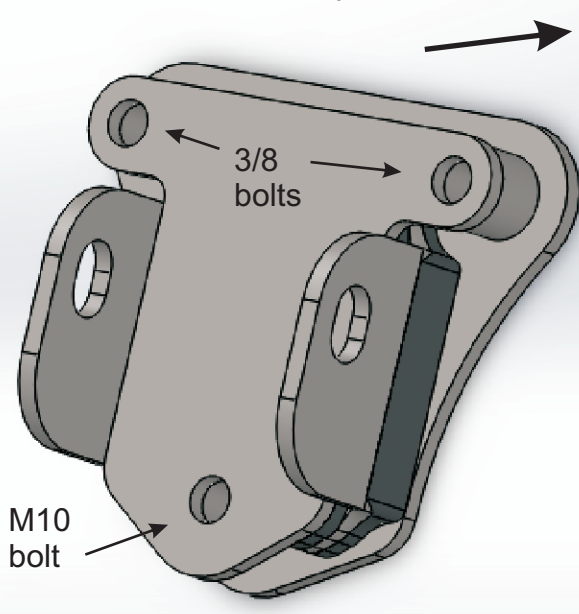

3x holes - for M10 bolts

- Bolt to engine block
- tighten to 40-45Nm

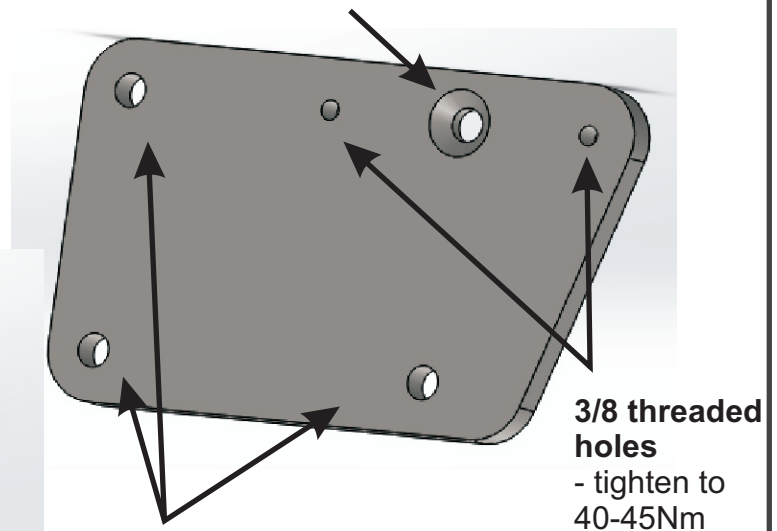

N.B: It is recommended that a licenced workshop or tradesperson carry out the above procedure and that workshop manual and relevant safety procedures are followed in addition to the above.