

Instruction Sheet

Front Radius Rod Bushing

N.B: This instruction sheet should be used in conjunction with the workshop manual

Application - Nissan S series

Contents - 2x bushing 91299
- 2x steel tubes
- grease

- Raise vehicle evenly and safely support.

Never rely on a Jack only

- Remove wheels and proceed to un-bolt Radius Arms.
- The original bushing will need to be pressed out with hydraulic Press.
- Remove bushing including steel outer shell.
- Press new supplied bushing in Eye - this is best done with soapy water.
- Grease bushing ID and face with supplied grease only.
- Push in supplied steel tube - bolt up arm to vehicle.
- Tighten all bolts to manufacturers spec
- Re-check after 100 kms travelled.

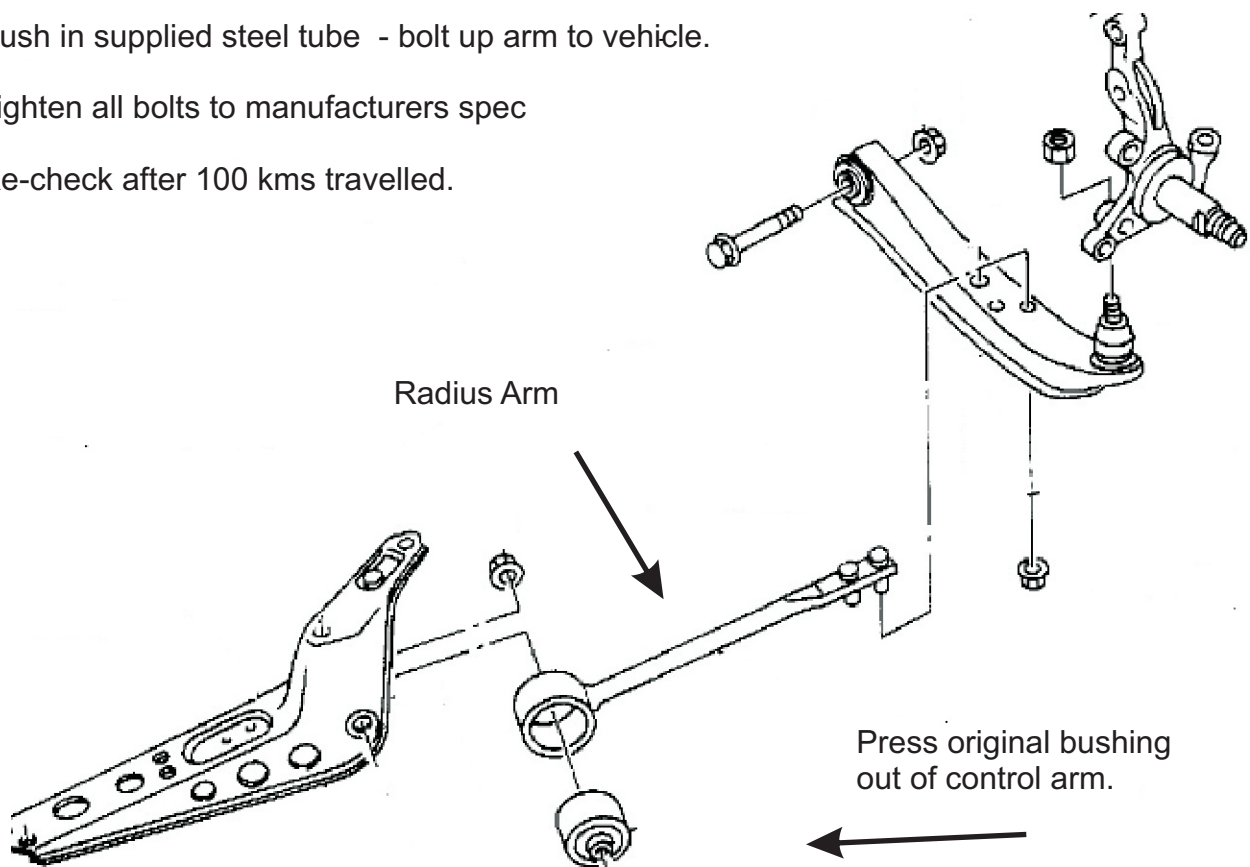

N.B: It is recommended that a licenced workshop or tradesperson carry out the above procedure and that workshop manual and relevant safety procedures are followed in addition to the above.