

Instructions

Front Trailing Arm Bushings

N.B: This instruction sheet should be used in conjunction with the workshop manual and proper safety procedures followed.

Page 1 of 2

Application - Jeep Wrangler TJ
- 1997-2006

Always refer complete catalogue listing

- Raise vehicle evenly and safely support with stands.

Never rely on a Jack only

Note - lubricate all bolts prior to removal

IMPORTANT - these bushings are designed to replace the rubber material only - do not remove the steel shell pressed into the arm.

- Remove only 1 trailing arm at a time.
- Press out the rubber only - may require heat to delaminate the rubber from steel shell.
- Clean all rubber from shell - remove any dirt or grease also.
- Discard the inner steel tubes.
- Push new supplied bushings into arm - refer diagram below and on page 2
- Grease bushing internal diameter and face with supplied grease only.
- Re-use original bolts.

Tighten upper bolts to 40Nm

Tighten lower bolts to 100Nm

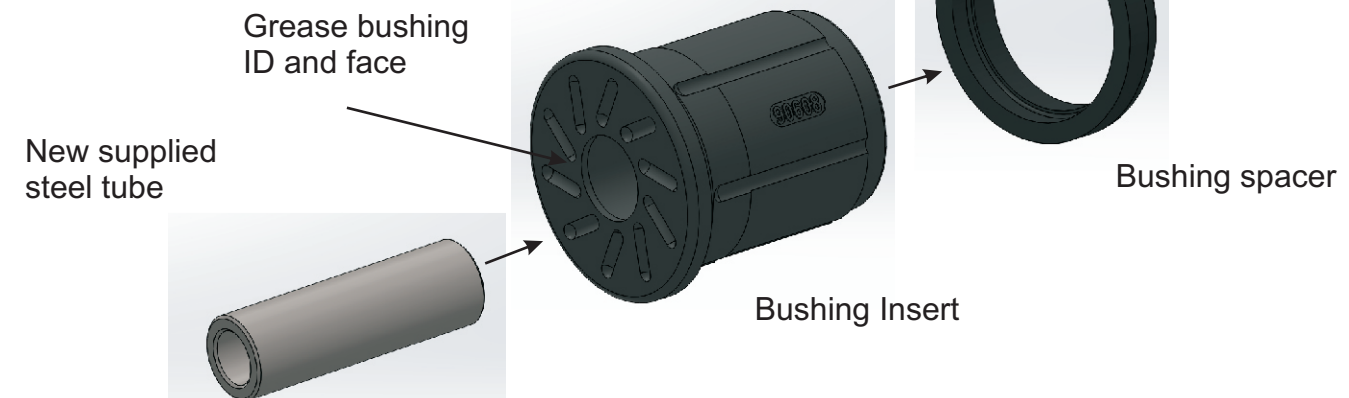

N.B: It is recommended that a licenced workshop or tradesperson carry out the above procedure and that workshop manual and relevant safety procedures are followed in addition to the above.

Instructions

Front Trailing Arm Bushings

N.B: This instruction sheet should be used in conjunction with the workshop manual and proper safety procedures followed.

Continued - page 2 of 2;

- Refer bushing number with position on vehicle below.

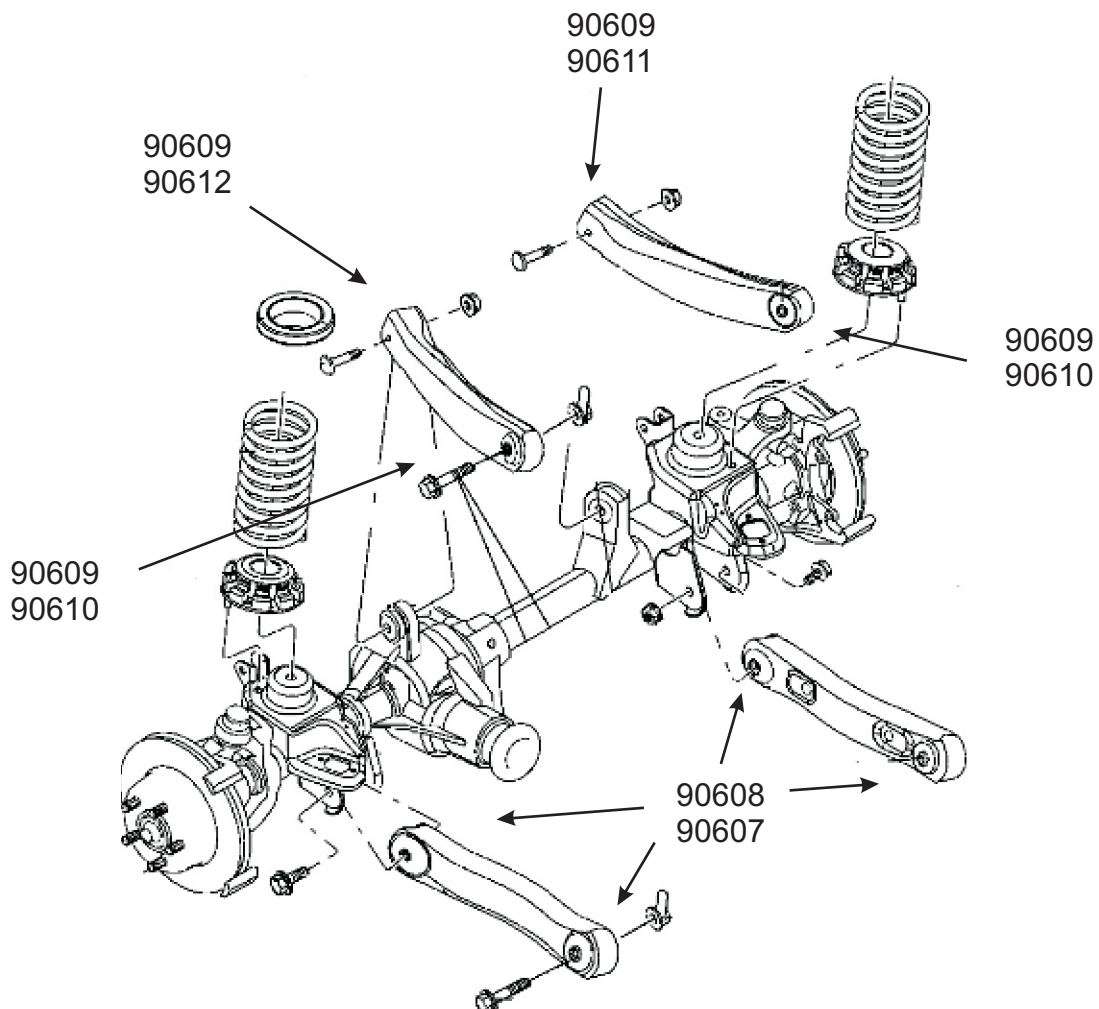

- Re-check all bolts after 100kms travelled.

Please drive safely while you accustom yourself yo the vehicles changed behaviour