

Instructions

Body Mount Bushings

N.B: This instruction sheet should be used in conjunction with the workshop manual and proper safety procedures followed.

Page 1 of 2

Note: Any rusted nuts or bolts will require lubricant prior to disassemble.

When removing each mount, be sure to note each location on vehicle. Also, any existing shims will need to be re-used in their respective point

- Loosen all bolts on both sides of vehicle initially.

Be careful of fan shroud and other components while lifting. A hydraulic jack and timber may be used to lift the body.

- Proceed by replacing mounts from 1 side of vehicle at a time.
Note - new bolts are supplied.

- Replace 1 mount at a time, but do not tighten new bolts yet - note diagram on page 2 for bushing position.

- Once all mounts are replaced, confirm body is straight/aligned - tighten all nuts to Manufacturers specifications.

- It is recommended all hardware is re-checked after 500kms travelled.

Application - Chev Blazer K5
- 4WD 1981-1992

(Refer current catalogue for complete listing)

Contents - Bushing 90283 x6
- Bushing 90284 x6
- Bushing 90287 x2
- Bushing 91564 x4
- Bushing 91565 x2
- Steel tubes 25.4x20x48.5 x2
- Steel tubes 25.4x16.2x42.5 x2

- Steel washer 63mm OD x6
- Steel washer 76mm OD x2

- Nut M10 Nyloc x4 (for rear bumper bar bolts)

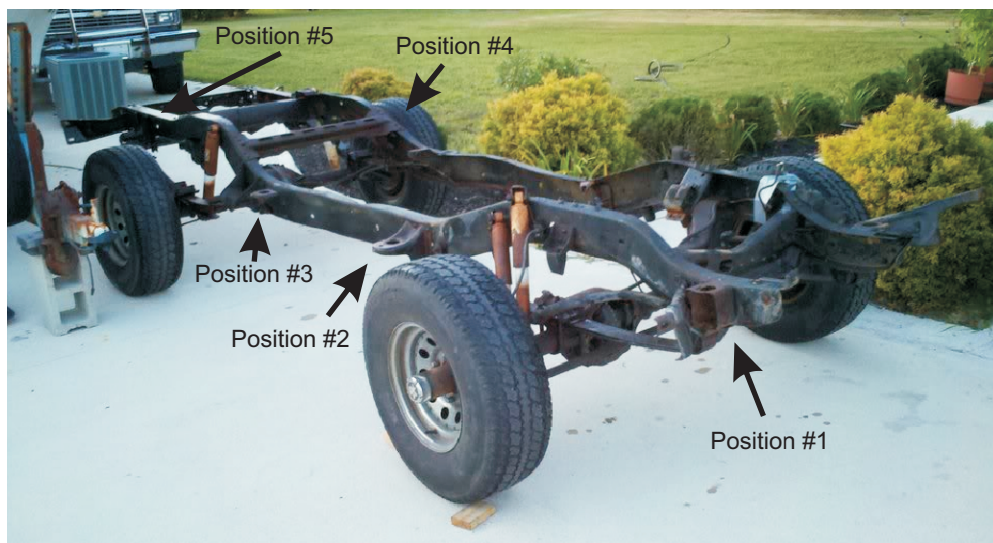

N.B: It is recommended that a licenced workshop or tradesperson carry out the above procedure and that workshop manual and relevant safety procedures are followed in addition to the above.

Instructions Body Mount Bushings

N.B: This instruction sheet should be used in conjunction with the workshop manual and proper safety procedures followed.

Page 2 of 2

Bushing 90283

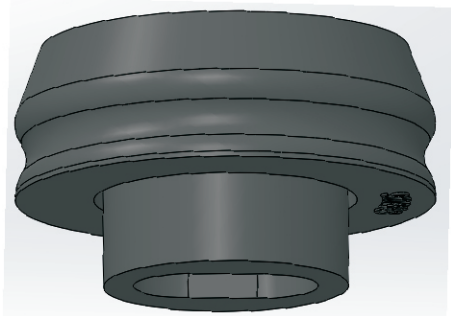

Positions #1/2/3

63mm OD washer



Bushing 90284

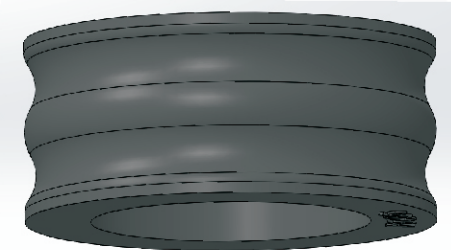

Bushing 91565

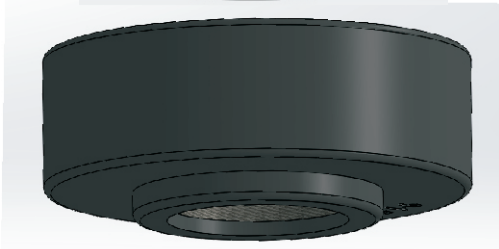

Position #4

Use Steel tubes 25.4x16.2x42.5

76mm OD washer



Bushing 91564

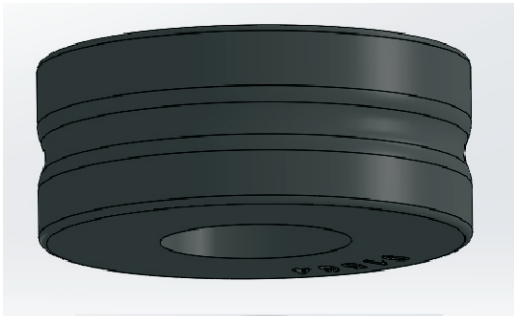

Bushing 90287

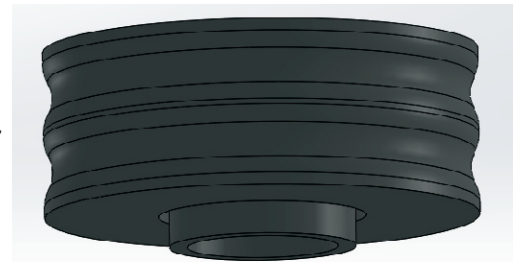

63mm OD washer



Position #5 Use Steel tubes 25.4x20x48.5

Bushing 91564

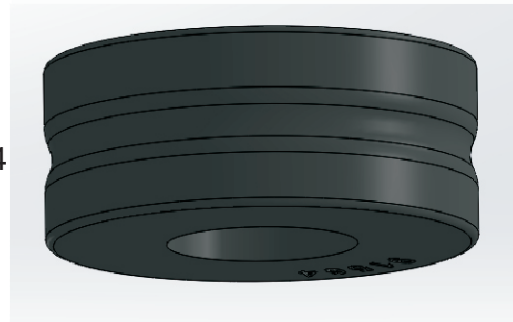

63mm OD washer

