

# Instructions

## Body Mount Bushings

**N.B:** This instruction sheet should be used in conjunction with the workshop manual and proper safety procedures followed.

*Page 1 of 2*

Note: Any rusted nuts or bolts will require lubricant prior to disassemble.

When removing each mount, be sure to note each location on vehicle. Also, any existing shims will need to be re-used in their respective point

1. Loosen all bolts on both sides of vehicle initially.

**Be careful of fan shroud and other components while lifting. A hydraulic jack and timber may be used to lift the body.**

2. Proceed by replacing mounts from 1 side of vehicle at a time.

3. Replace 1 mount at a time, but do not tighten bolts yet - note diagram on page 2 for bushing position.

4. Once all mounts are replaced, confirm body is straight/aligned - tighten all nuts to Manufacturers specifications.

5. It is recommended all hardware is re-checked after 500kms travelled.

**Application** - Chevrolet Impala

- 1959-1964

*(Refer current catalogue for complete listing)*

**Contents** - 8x steel washers 63mm OD  
 - 8x steel washers 50mm OD  
 - 2x steel washers 20mm OD  
 - 8x bushings 90651  
 - 8x bushings 90652  
 - 8x steel tubes 37.5mm L  
 - 2x steel plates  
 - 2x 3/8 bolts  
 - 8x 7/16 bolts



**N.B:** It is recommended that a licenced workshop or tradesperson carry out the above procedure and that workshop manual and relevant safety procedures are followed in addition to the above.

# Instructions Body Mount Bushings

Page 2 of 2

## Positions #2, #3, #4, #5

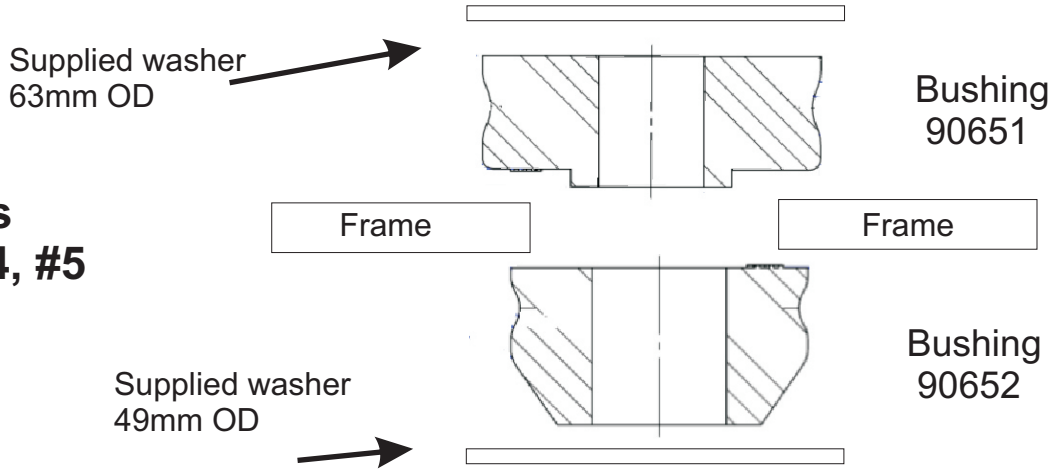

Use new supplied 7/16 bolt on points 2, 3, 4 and 5

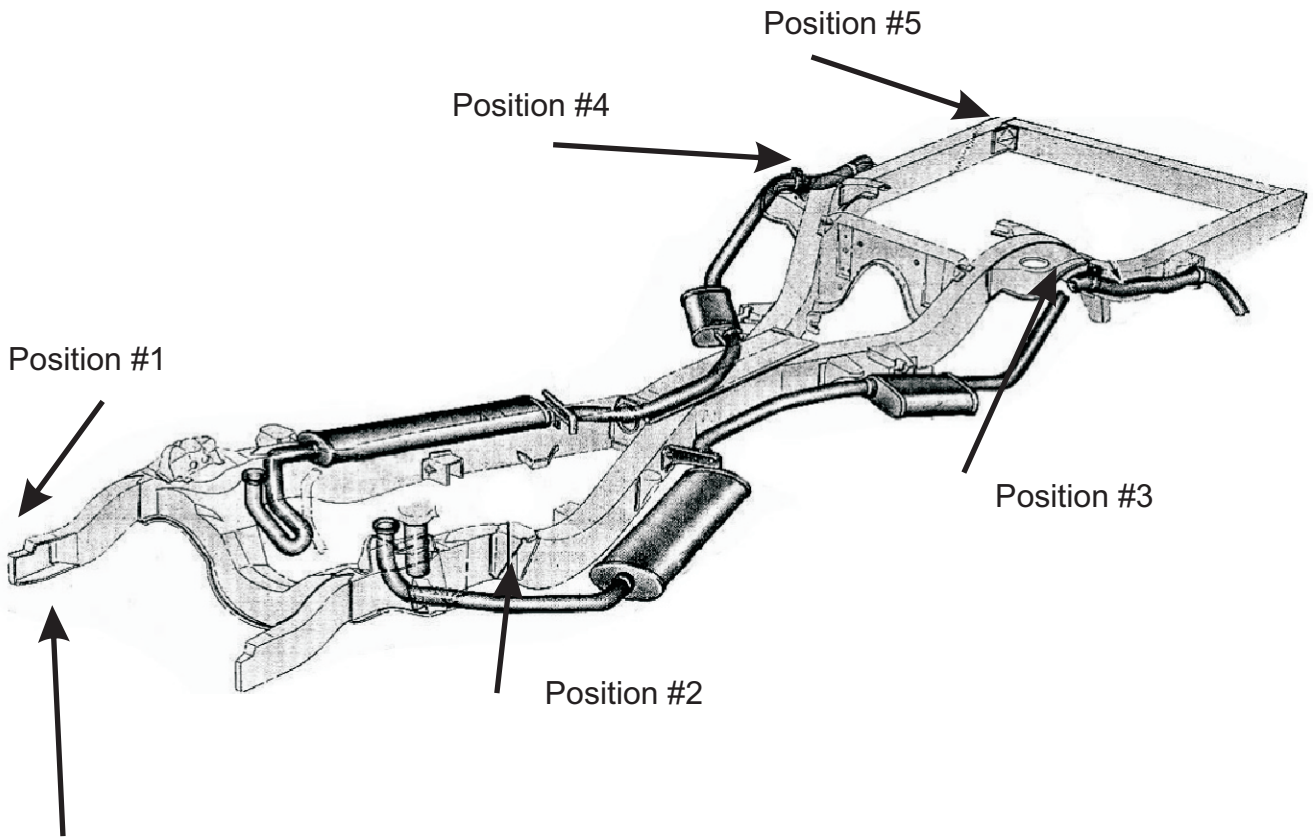

Note - for position #1, use only flat plate, 20mm washer and 3/8 bolt (not bushings)