

Instructions

Body Mount Bushings - Sub-frame

N.B: This instruction sheet should be used in conjunction with the workshop manual and proper safety procedures followed.

Page 1 of 2

Note: Any rusted nuts or bolts will require lubricant prior (and maybe wire brush) to disassemble.

When removing each mount, be sure to note each location on vehicle. Also, any existing shims will need to be re-used in their respective point

Application - Dodge Charger
- 1973-1979

(Refer current catalogue for complete listing)

Contents - Bushing 91802 X2
- Bushing 91803 X2
- Bushing 91804 x4

- Steel tube 22.2x16.2x60 x2
- Steel tube 22.2x16.2x66 x2

- Steel washer 75mm OD x8

- Loosen all bolts on both sides of vehicle initially.

**Be careful of fan shroud and other components while lifting.
A hydraulic jack and timber may be used to lift the body.**

- Proceed by replacing mounts from 1 side of vehicle at a time.
Note - new bolts are supplied.

- Replace 1 mount at a time, but do not tighten new bolts yet - note image below and diagram on page 2 and 3 for bushing position.

- Once all bushings are in position, tighten all bolts.

- Re-check all bolts after 500miles.



Sub-frame - Position #1

Position #2

N.B: It is recommended that a licenced workshop or tradesperson carry out the above procedure and that workshop manual and relevant safety procedures are followed in addition to the above.

Instructions

Body Mount Bushings - Sub-frame

Continued - page 2 of 2

Position #1

Upper bushing 91802

Steel tube 22.2x16.2x60mm

Lower bushing 91804

Washer 75mm OD

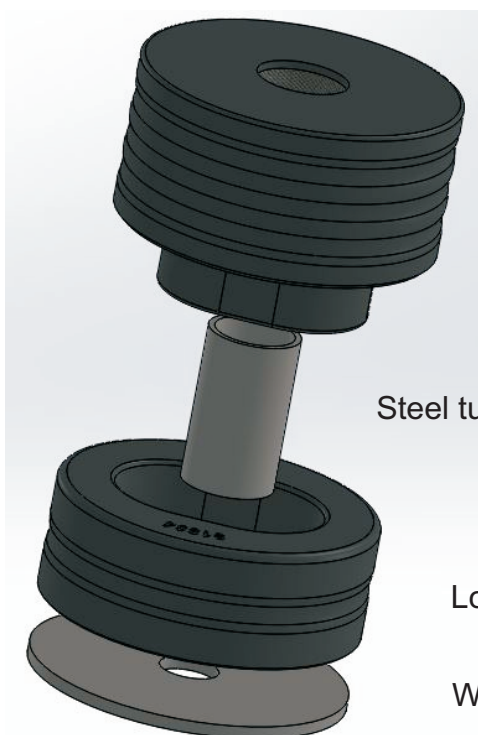
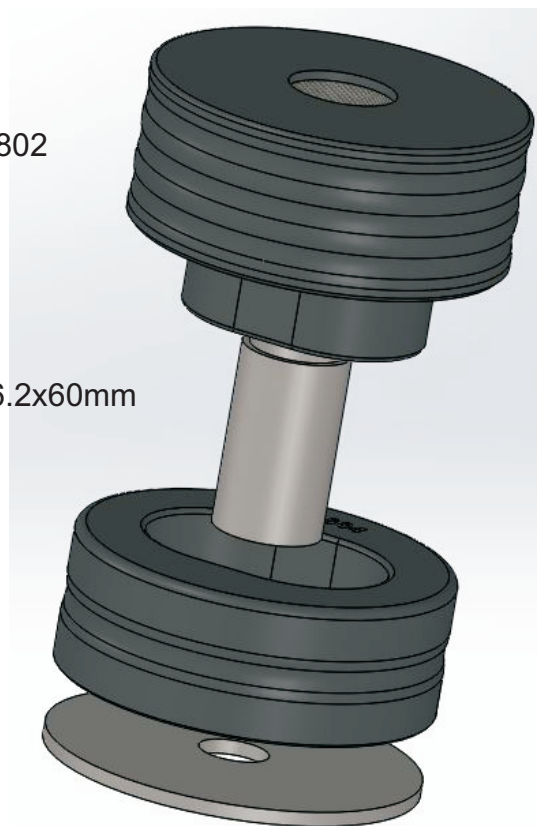

Upper bushing 91803

Steel tube 22.2x16.2x66mm

Lower bushing 91804

Washer 75mm OD

Position #2

N.B: It is recommended that a licenced workshop or tradesperson carry out the above procedure and that workshop manual and relevant safety procedures are followed in addition to the above.