

## Idler Arm Bushes

1. Remove idler arm from the vehicle paying attention to the angle the arm leaves the chassis pin, and the fitment of the chassis and drag link end bushes.
2. Support the idler arm and remove old bushes. Clean and examine arm for cracks, bending and wear. Discard worn or damaged arms.
3. Using a suitable press, install bushes noting the direction the bushes enter the arm and the spacing of the head and the shank lengths. Refer diagram below. Non compliance with the spacing shown will result in premature wear of the new bushes.

Torque settings for both bushes: 60 Nm (45 ft lbs)

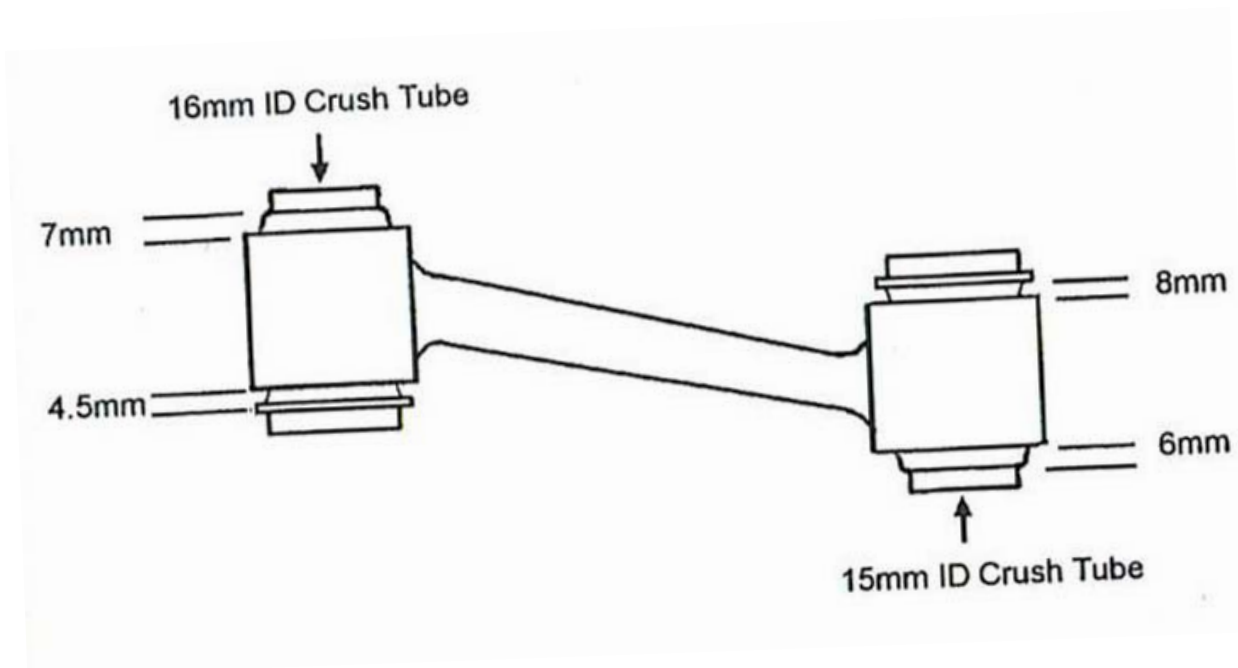

**This procedure must be carried out by a qualified person**

# Installation Guide

## STRUT TOP- HAT ORIENTATION

### Suits : HOLDEN COMMODORE VR-VE SERIES

(Always refer to the current catalogue for complete application listings).  
 N.B. This install guide should be used in conjunction with the workshop manual.

#### PLEASE NOTE DAMPER-COIL OFFSET

Prior to disassemble please take note of alignment OE markings on both the lower spring seat and upper strut hat  
 (THESE MARKINGS WILL VARY DEPENDING ON THE YEAR MODEL)

#### FRONT STRUT/SHOCK ASSY

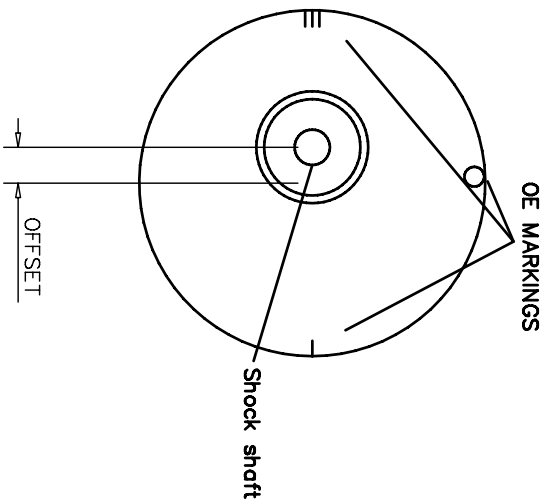

#### OE UPPER STRUT HAT

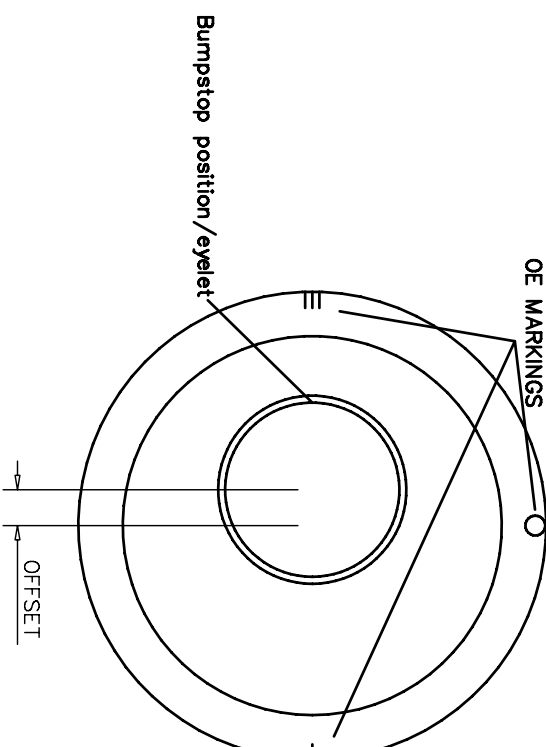

#### TOP VIEW OF DISASSEMBLED STRUT

N.B. It is recommended that a licenced workshop or trades person carry out the above procedure and that workshop manual and relevant safety procedures are followed in addition to the above.