

Instructions

Front Control Arm Bushings

N.B: This instruction sheet should be used in conjunction with the workshop manual and proper safety procedures followed.

Application - Chev Cavalier
- Pontiac Sunfire
- 1995-2004

Always refer complete catalogue listing

Contents - 4x bushing 91955
- Steel tubes 19x12x58mm
- 2x Vertical bushings 82020
- Grease

- Raise vehicle evenly and safely support.

Never rely on a Jack only

- Proceed to un-bolt wheels.
- Loosen ball joint nut, but don't remove yet. Strike hub with hammer to break ball joint taper.
- Un-bolt and remove front bushing and rear bushing bolts - refer image below.
- Using a hydraulic Press, press out the rear vertical mount bushing.
- For the smaller front bushing, you will require a threaded puller to remove.
- Clean control arm from any burs or oil/grease. Proceed to press in new rear bushings. Push in new front bushing 91955 by hand, grease bushing ID and face with supplied grease.
- Re-fit arms to vehicle. Refer Torque spec below.
- A wheel alignment is required after install.

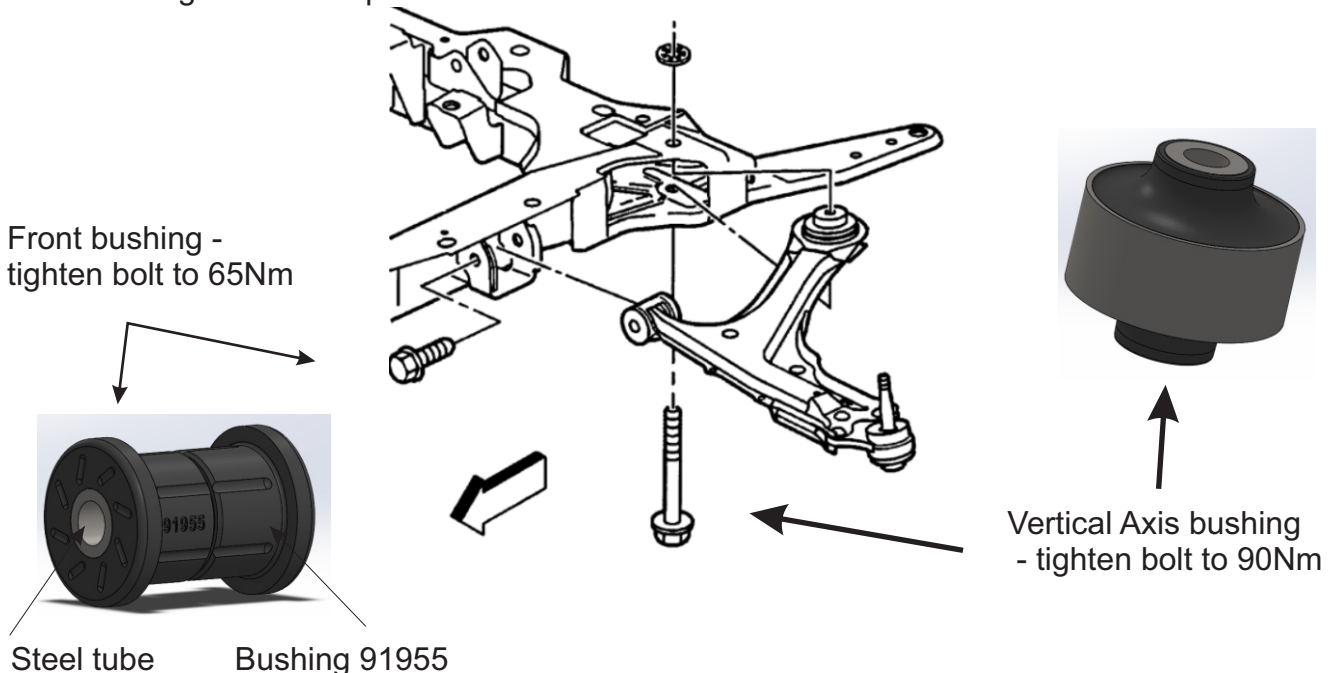

N.B: It is recommended that a licenced workshop or tradesperson carry out the above procedure and that workshop manual and relevant safety procedures are followed in addition to the above.