

STEERING COUPLING TO SUIT FORD FALCON POWER AND NON POWER STEERING SYSTEMS, TO XF

1. Remove original coupling assembly from steering box and shaft
2. Grind or drill- out rivets to allow removal of original coupling from locators
3. Clean all metal surfaces of locators especially those which will contact the new coupling
4. Follow instructions below, fit new coupling between steering shaft and steering box. Use new bolts, washers and lock nuts supplied in kit. Pay attention to the length of bolts used and outer diameter of crush tubes in the coupling.
5. Tighten all nuts securely. Crush tubes limit the amount of pressure applied to the coupling
6. In all cases, the bolt heads and locknuts must seat on the original metal flange or the washer supplied. Under no circumstance must a bolt head or nut seat directly against the flexible material.

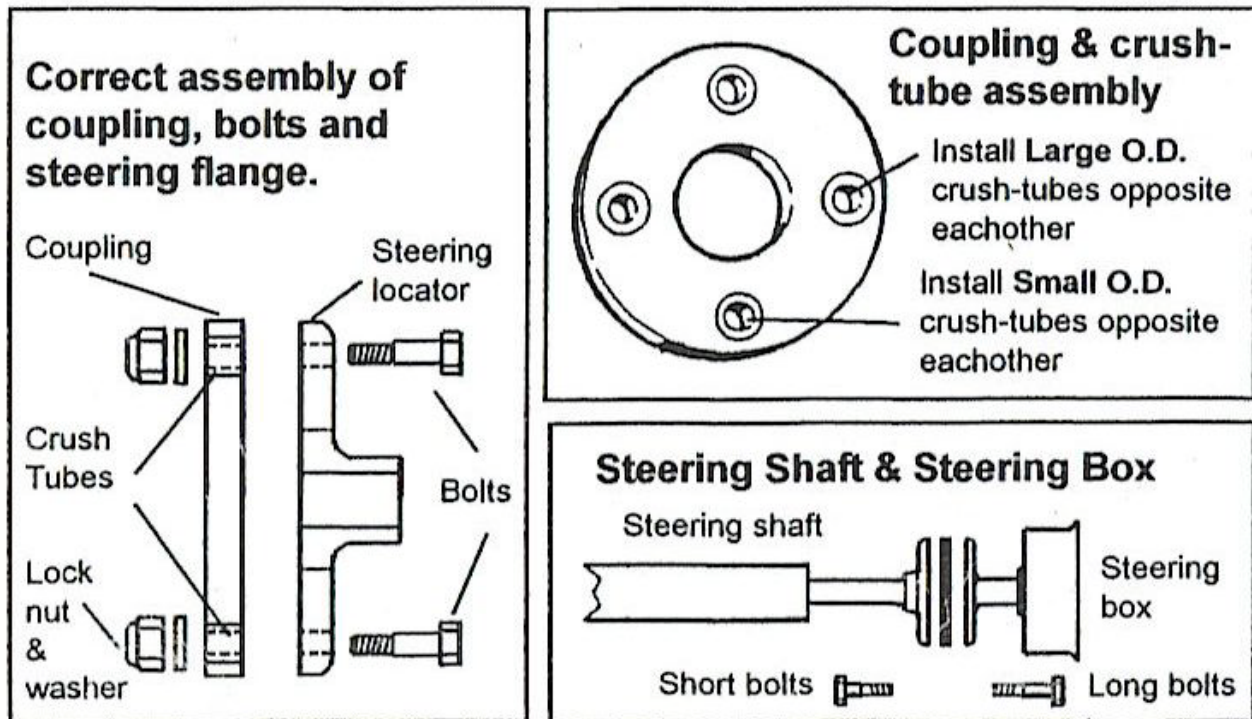

This procedure must be carried out by a qualified person