

Instructions

Radiator and Body Mount Bushings

N.B: This instruction sheet should be used in conjunction with the workshop manual and proper safety procedures followed.

Rusty bolts may require lubricant prior to loosening.

Loosen all bolts but only remove/service one side at a time.

Only lift body enough to remove old bushings.
Use a jack with timber to ensure no damage to body.

Be mindful of fan shrouds and brake lines.

Re-use any existing shims.

**NOTE - lower washer/nut may be tight to remove.
Best method to remove - screw bolt in from the bottom,
then hit bolt down from the top with a Pin Punch.**

Original bolts, nuts and washers to be re-used.

Tighten bolts to manufacturers spec - re-check after initial 500kms after settle period.

Application - Ford F series Trucks
- 1980-1996
(Refer current catalogue listing)

Contents -

Bushing 90618 x 2
Bushing 90619 x 2
Bushing 90620 x 2
Bushing 90621 x 2
Bushing 90622 x 2
Bushing 90623 x 2

Bushing position reference:

Front mount-
Upper bushing 90622
Lower bushing 90623

2nd mount-
Upper bushing 90620
Lower bushing 90621

3rd mount-
Upper bushing 90618
Lower bushing 90619

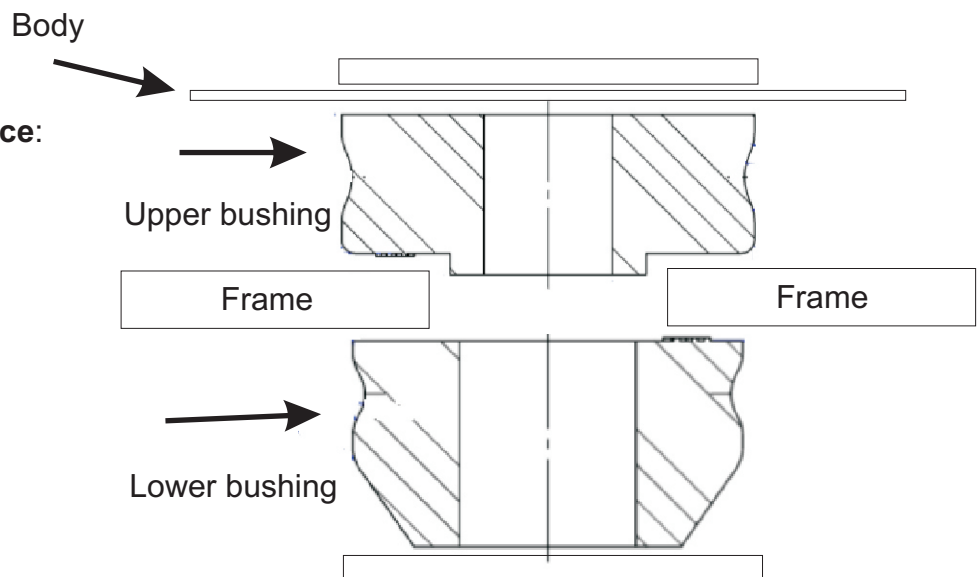

N.B: It is recommended that a licenced workshop or tradesperson carry out the above procedure and that workshop manual and relevant safety procedures are followed in addition to the above.