

# Instructions

## Body Mount Bushings

**N.B:** This instruction sheet should be used in conjunction with the workshop manual and proper safety procedures followed.

*Page 1 of 2*

**Application** - Chev C and K series  
- 4WD

*(Refer current catalogue for complete listing)*

Note: Any rusted nuts or bolts will require lubricant prior to disassemble.

When removing each mount, be sure to note each location on vehicle. Also, any existing shims will need to be re-used in their respective point

**Contents** - Bushing 90283 x8  
- Bushing 90284 x8

- Loosen all bolts on both sides of vehicle initially.

**Be careful of fan shroud and other components while lifting. A hydraulic jack and timber may be used to lift the body.**

- Proceed by replacing mounts from 1 side of vehicle at a time.  
Note - new bolts are supplied.
- Replace 1 mount at a time, but do not tighten new bolts yet - note image below and diagram on page 2 for bushing position.
- Once all mounts are replaced, confirm body is straight/aligned - tighten all nuts to Manufacturers specifications.
- It is recommended all hardware is re-checked after 500kms travelled.

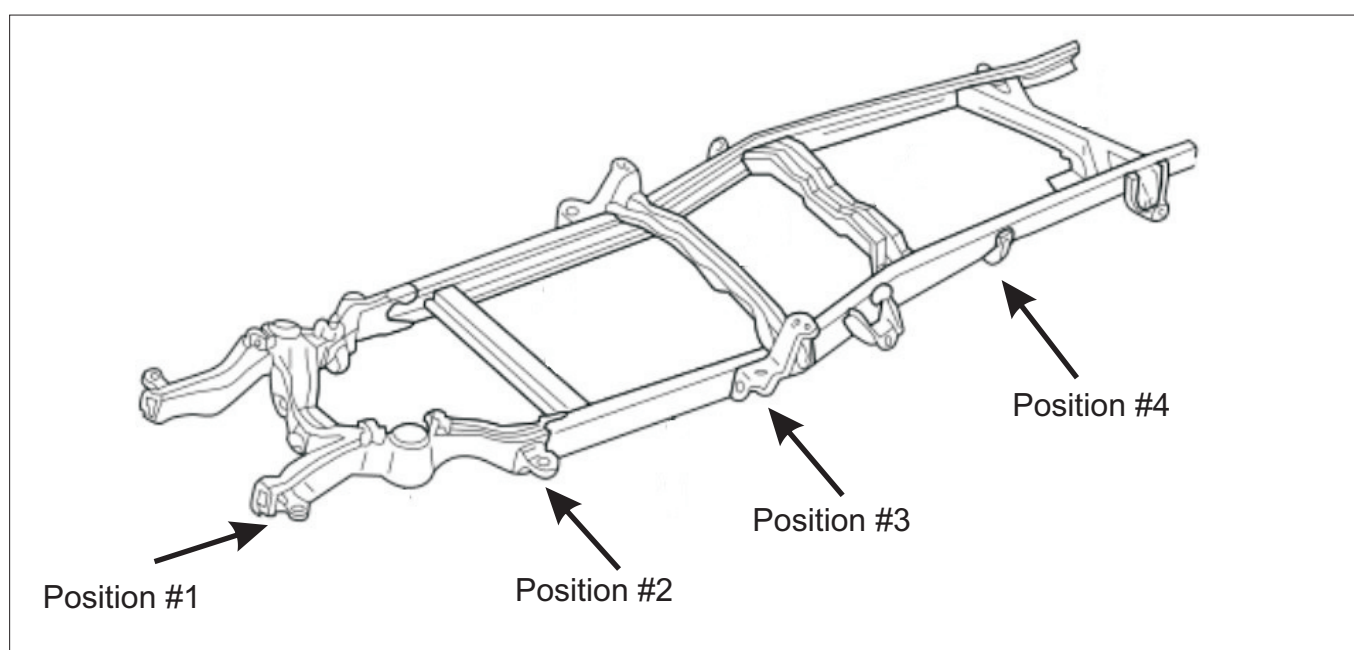

**N.B:** It is recommended that a licenced workshop or tradesperson carry out the above procedure and that workshop manual and relevant safety procedures are followed in addition to the above.

# Instructions

## Body Mount Bushings

*Continued - page 2*

Note - use same bushings for all 8 points

Re-use original washers, tubes and bolts (unless rusty - replace as required).

Position #1 - remove headlight and grill to properly access mount.

Bushing 90283  
Upper mount

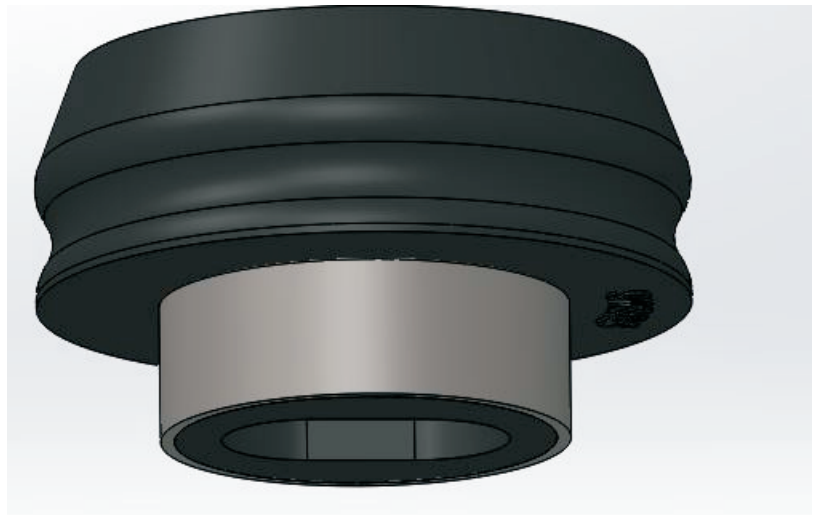

Bushing 90284  
Lower mount

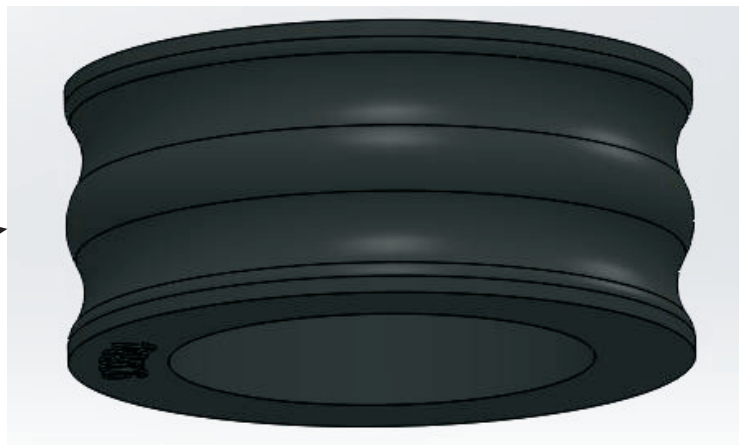

N.B: It is recommended that a licenced workshop or tradesperson carry out the above procedure and that workshop manual and relevant safety procedures are followed in addition to the above.