

# Instructions

## Shock Bushings

**N.B: This instruction sheet should be used in conjunction with the workshop manual and proper safety procedures followed.**

### Install Guide

1. Raise vehicle evenly and safely support - wheels need to be hanging.
2. Remove wheels and proceed to un-bolt lower Control Arm.
3. Un-bolt strut and remove from vehicle.

Note: Take proper safety precautions when disassembling strut assembly - follow manufacturers procedure or injury will occur.

A spring compressor is required and should be operated by a qualified person.

4. Once Strut Top is removed, replace both upper bushings using OE washers and nut.
5. Re-assemble Strut.
6. Press out lower Shock Bushing (including outer shell).
7. Confirm eyelet has no burs, dirt or rust.
8. Push in 2-piece bushings as per diagram.  
Grease ID and faces - push in supplied steel tube.
9. Re-fit Control Arm to vehicle. Tighten bolts to manufacturers spec.
10. A wheel alignment is recommended.
11. Re-check bolts after initial 100kms travelled.

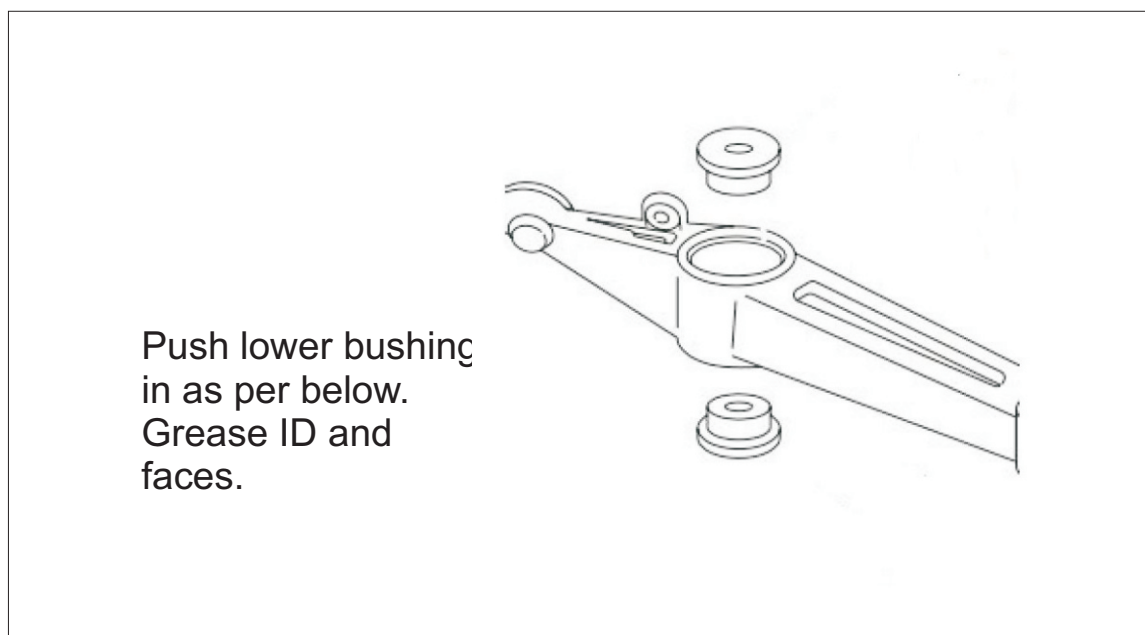

N.B: It is recommended that a licenced workshop or tradesperson carry out the above procedure and that workshop manual and relevant safety procedures are followed in addition to the above.