

# Instructions

## Front Control Arm Bushings

Page 1 of 2

**N.B:** This instruction sheet should be used in conjunction with the workshop manual and proper safety procedures followed.

**Application** - Subaru Impreza  
- 1995 - 2006

*Always refer complete catalogue listing*

**Contents** - Bushing 68098 x 4  
- Bushing 5474 x 4  
- Large washer x 2  
- Steel tube 22mm OD x 2  
- Steel tube 30mm OD x 2  
- Grease

- Raise vehicle evenly and safely support.

*Never rely on a Jack only*

- Proceed to remove wheels and un-bolt control arms.
- Un-bolt rear aluminium mount - use a Press to push out the original bushing.
- You may need to drill a hole into the side of front bushing to relieve and then hit out.
- Clean Control Arm eyes of dirt and grease. Then proceed to push supplied bushing in.
- Refer image below for rear bushing in aluminium bracket.

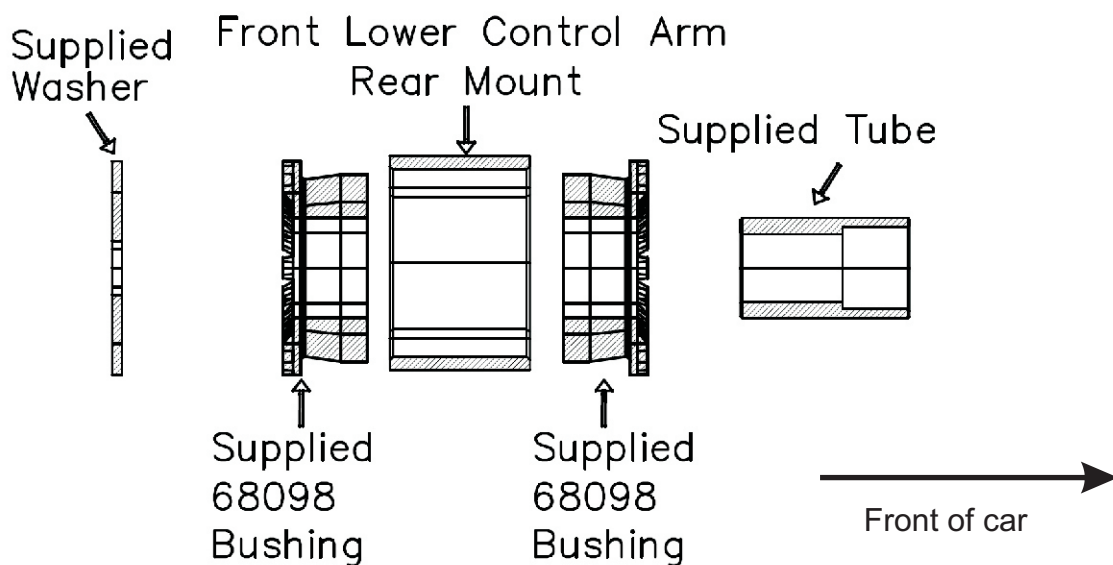

**N.B:** It is recommended that a licenced workshop or tradesperson carry out the above procedure and that workshop manual and relevant safety procedures are followed in addition to the above.

# Instructions

## Front Control Arm Bushing

*Continued - Page 2 of 2*

- Push in supplied bushings as per image below.
- Grease bushing internal bore and face with supplied grease only.
- Push in supplied steel tubes - note 30mm tube orientation on page 1.
- Re-fit Control Arm to vehicle using original bolts.
- A wheel alignment will be required after install.
- Re-check bolts after initial 100kms travelled.

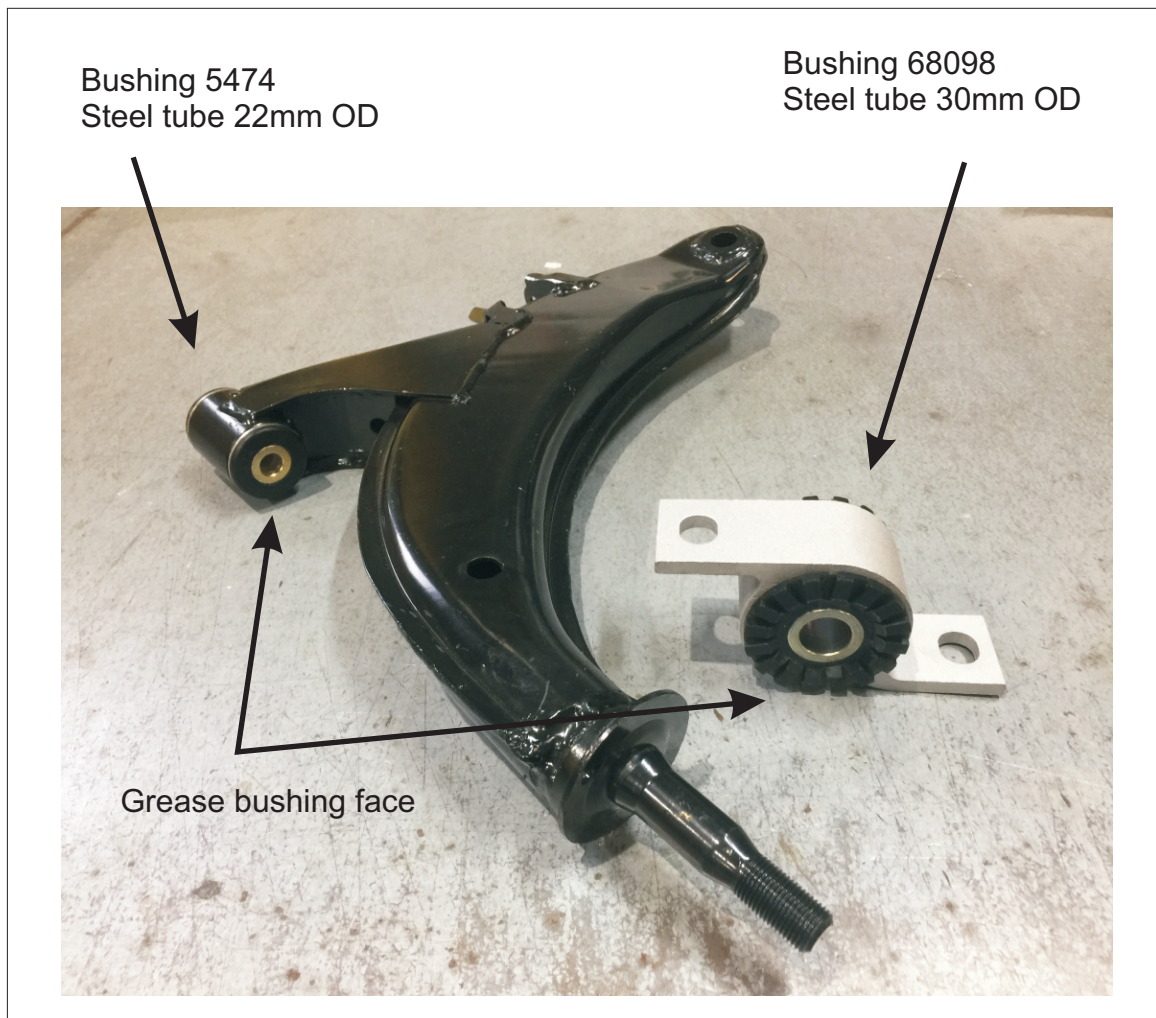

N.B: It is recommended that a licenced workshop or tradesperson carry out the above procedure and that workshop manual and relevant safety procedures are followed in addition to the above.