

# Instructions

## Body Mount Bushings

**N.B:** This instruction sheet should be used in conjunction with the workshop manual and proper safety procedures followed.

Page 1 of 2

**Application** - Chev Corvette  
- 1973-82

(Refer current catalogue for complete listing)

Note: Any rusted nuts or bolts will require lubricant prior to disassemble.

When removing each mount, be sure to note each location on vehicle. Also, any existing shims will need to be re-used in their respective point

**Contents** - Bushing 90658 x8  
- Bushing 90674 x8  
- Steel tube 22x16x38 x8  
- Flat washer 50x13x3 x16

- Loosen all bolts on both sides of vehicle initially.

**Be careful of engine components while lifting. A hydraulic jack and timber may be used to lift the body.**

- Proceed by replacing mounts from 1 side of vehicle at a time.
- Replace 1 mount at a time, but do not tighten bolts yet - note diagram on page 2 for bushing position.
- Once all mounts are replaced, confirm body is straight/aligned - tighten all nuts to Manufacturers specifications.
- It is recommended all hardware is re-checked after 500kms travelled.

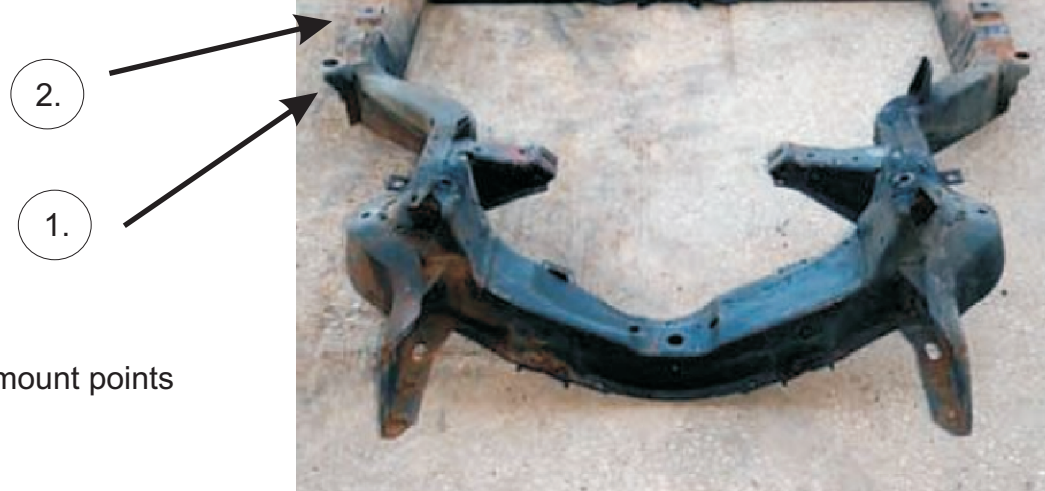

- Note chassis and mount points

Refer page 2 -

**N.B:** It is recommended that a licenced workshop or tradesperson carry out the above procedure and that workshop manual and relevant safety procedures are followed in addition to the above.

# Instructions Body Mount Bushings

N.B: This instruction sheet should be used in conjunction with the workshop manual and proper safety procedures followed.

### Position #1

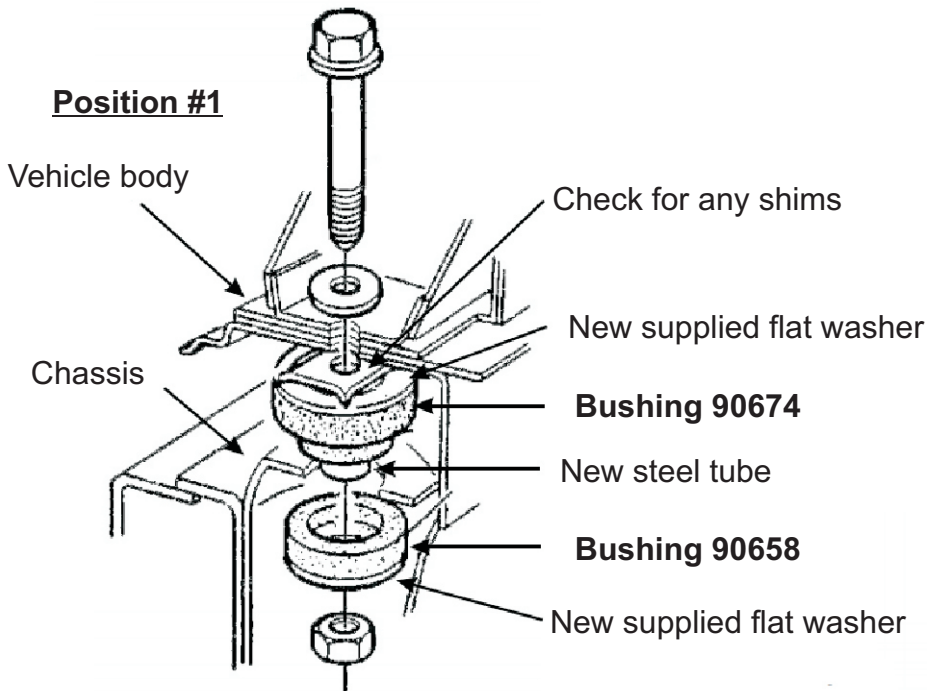

### Position #2/3

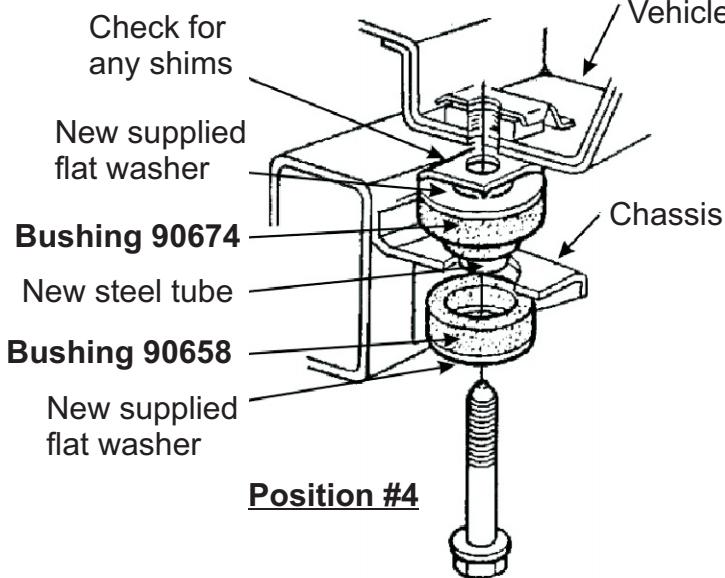
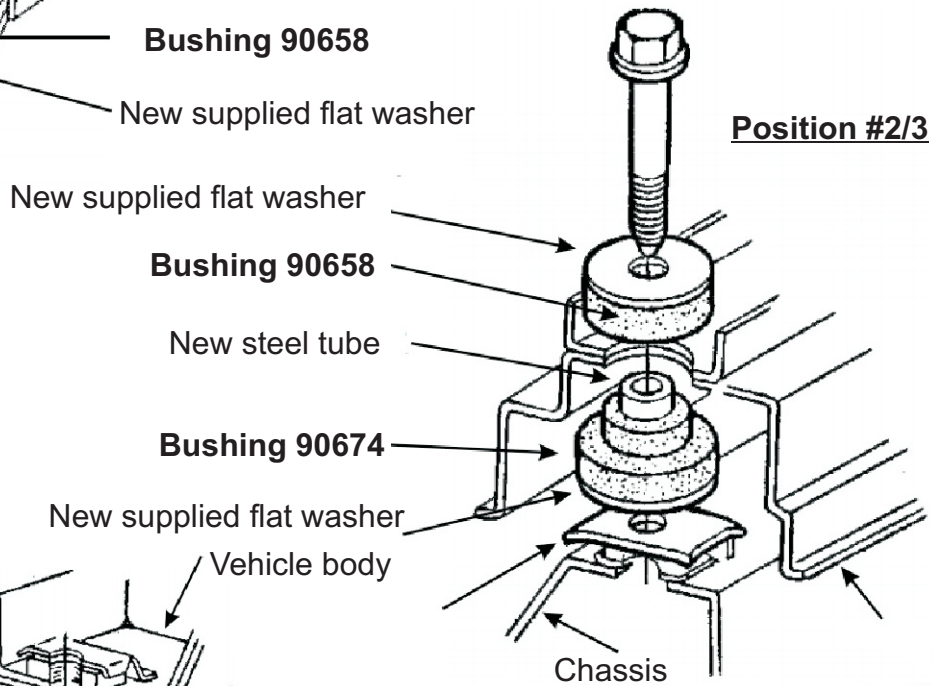

N.B: It is recommended that a licenced workshop or tradesperson carry out the above procedure and that workshop manual and relevant safety procedures are followed in addition to the above.