

Instructions

Body Mount Bushings

N.B: This instruction sheet should be used in conjunction with the workshop manual and proper safety procedures followed.

Page 1 of 2

Application - Ford F250/350 2005-07
- 2WD and 4WD
(Refer current catalogue listing)

Install Guide

Note - rusted bolts may require lubricant spray underneath mount prior to disassemble.

Contents - 4x bushing 91269
- 4x bushing 91275
- 2x bushing 91276
- 2x bushing 91286
- 2x bushing 91288
- 2x bushing 91289

- Access bolts from the upper side of body. The plastic trims will need to be removed - then slide carpet to the side.
- Loosen the bolts and un-wind bolt approx 25mm (don't remove bolt yet).

The OE Ford mounts need to be 'hit' apart - hit the bolt head with a mallet. This will separate the lower bushing from the frame.

- Proceed to lift the body - use a hydraulic Jack and timber (careful to not damage body)

Be careful of other components while lifting the Body. Such as brake lines.

- Proceed by replacing mounts from 1 side of vehicle at a time.
- Replace 1 mount at a time, but do not tighten bolts yet - note diagram on page 2 for bushing position.
- Once all mounts are replaced, confirm body is straight/aligned - tighten all nuts to Manufacturers specifications.
- It is recommended all hardware is re-checked after 500kms travelled.

N.B: It is recommended that a licenced workshop or tradesperson carry out the above procedure and that workshop manual and relevant safety procedures are followed in addition to the above.

Instructions

Body Mount Bushings

N.B: This instruction sheet should be used in conjunction with the workshop manual and proper safety procedures followed.

Page 2 of 2

Application - Ford F250/350 2005-07
- 2WD and 4WD
(Refer current catalogue listing)

Contents - 4x bushing 91269
- 4x bushing 91275
- 2x bushing 91276
- 2x bushing 91286
- 2x bushing 91288
- 2x bushing 91289

This kit is designed to service F250 and F350 Super Duty - Crew Cab Trucks.

There are 4 positions - please refer image below

Re-use all original steel cups and washers.

You may need to peel old rubber away from original washers.

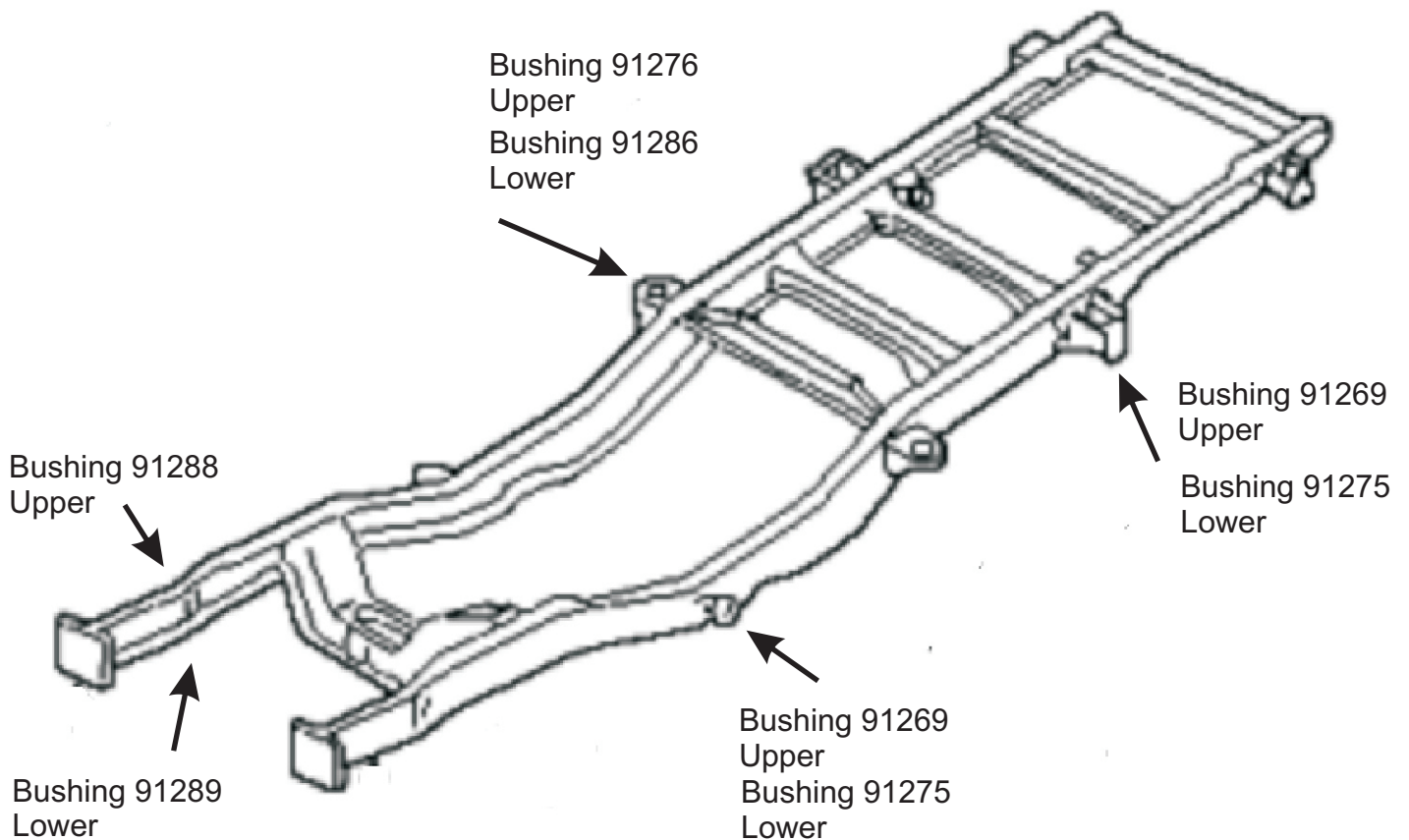

N.B: It is recommended that a licenced workshop or tradesperson carry out the above procedure and that workshop manual and relevant safety procedures are followed in addition to the above.