

Instructions

MOTOR MOUNT KIT

N.B: This instruction sheet should be used in conjunction with the workshop manual and proper safety procedures followed.

- Raise vehicle evenly and safely support.

Never rely on a Jack only.

Replace only 1 mount at a time
Best to wait till engine has cooled down.

- Start by supporting engine - use a jack and timber to lift engine - careful to not damage sump. Don't lift engine under crank pulley.

- Proceed to unbolt mount from engine block. Also the long bolt through the lower bracket.

- Remove the OE mounting bracket also. Cut or flatten out the small tab at the end - note lower RH image.

- Lift Motor slightly higher to aid install.

- Bolt up new mount but do not tighten any bolts until all bolt threads are started.

- Once all bolts are in position tighten.

- Re-check all bolts after 100 miles

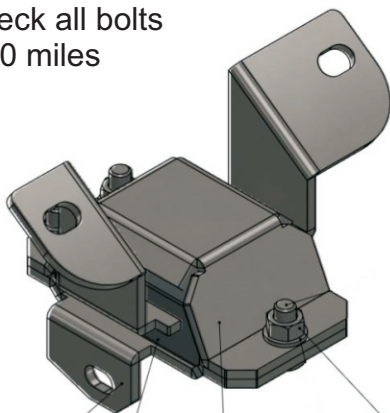

Rust proof plating

Firm poly material

Check nuts are tight

Application - Early Ford Mustang
 - 1966-72

Always refer complete catalogue listing

Contents - 2x complete engine mounts

Un-bolt mount



Flatten Tab



N.B: It is recommended that a licenced workshop or tradesperson carry out the above procedure and that workshop manual and relevant safety procedures are followed in addition to the above.