

INSTALLATION GUIDE

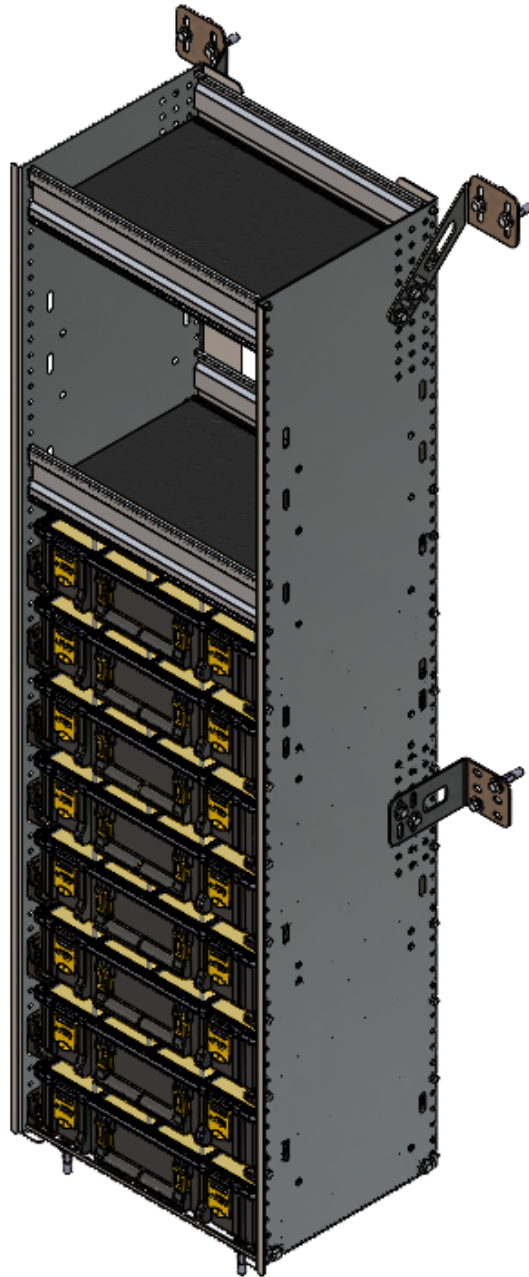

C5-PA18-8C Partskeeper Cabinet



For full install guide visit:
<https://rangerdesign.com/products/partskeeper-parts-organizer-aluminum-storage-cabinet-w-8-carry-cases-2-shelves-c5-pa18-8c/>



QUICK START GUIDE

Phase 1 - Assembly

- 1.1 Setup..... 3 - 5
- 1.2 Shelf Assembly..... 6 - 7

Phase 2 - Installation

- 2.1 Attach Wall Brackets To The End Panels..... 8
- 2.2 Mark Holes For Plus Nuts..... 9
- 2.3 Attach Plus Nut..... 10 - 11
- 2.4 Attach Partskeeper Cabinet To the Floor..... 12 - 13
- 2.5 Attach Wall Brackets..... 14 - 15

REQUIRED ITEMS

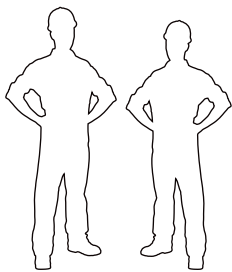

2
PERSONS

- Cordless Impact
- Cordless Drill
- Tape Measure
- Marker
- 1/2" Socket
- 1/2" Drill Bit w/ Drill Collar (Set at 1/2")
- 3/8" Driver Bit
- Knife
- Plusnut Tool / Plusnut Gun (5/16")

PHASE 1 – ASSEMBLY

1.1 SETUP

1.1.1 Unpack components; compare with the bill of materials.

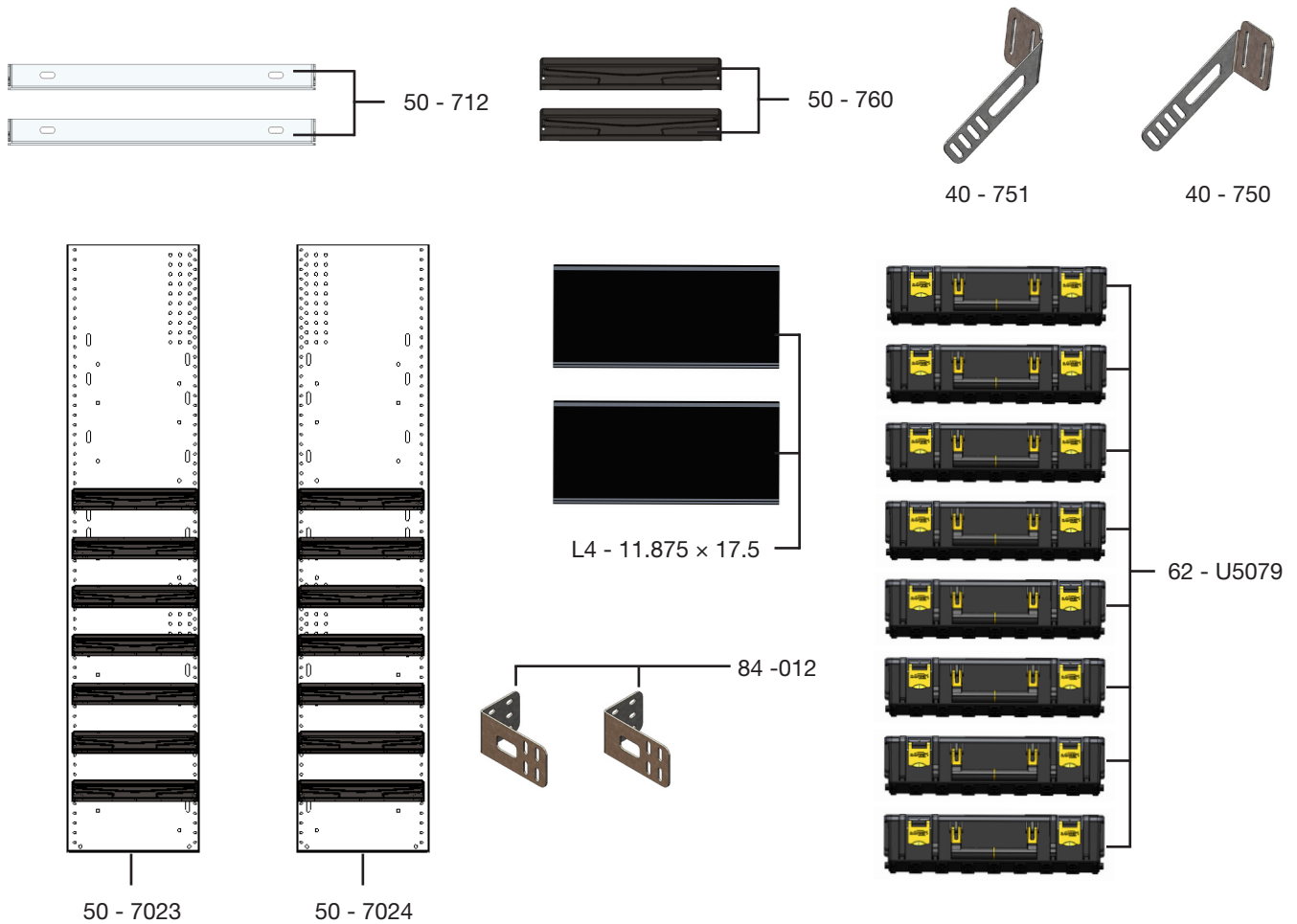

1.1.2 Verify all parts are present.

BILL OF MATERIALS

Item No.	Description	Qty.
40 - 750	Bracket, N5 Series, Right	1
40 - 751	Bracket, N5 Series, Left	1
84-012	Foldaway bracket - middle	2
50 - 760	Partskeeper Rail	2
50 - 7023	End Panel (Left)	1
50 - 7024	End Panel (Right)	1
62-U5079	Plastic Partskeeper Case	8
L4 - 11.875 x 17.5	Shelf Tray, Composite, Usable 12" x 17.5"	2
94 - 5023	Assembly Fastener Kit	1
96 - 5023	Install Fastener Kit	1
84-012	foldaway bracket - middle	2

1.1.3 Fastener kits.

94 - 5023 Fastener Kit



Fastener Assembly

12x



90-204

Hex Bolt
5/16"-18 x 3/4"
GR-5 ZINC

4x



90-012

Screw HWH
1/4"-10 x 3/4"
ZINC

16x



92-102

Screw HWH
#14 x 1"
ZINC

16x



94-116

Serrated Nut
5/16"-18
ZINC



12x



98-116

Flat Washer
5/16"
ZINC

12x

	#90-204 Hex Bolt	5/16" x 3/4"
	#98-116 Flat Washer	5/16"
	#94-116 Serrated Nut	5/16"

4x

	#90-012 Screw	1/4"-10 x 3/4"
--	---------------	----------------

16x

	#92-102 Screw	#14 x 1"
---	---------------	----------

96 - 5023 Fastener Kit

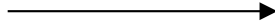

Fastener Assembly

4x  # 90-011 Hex Bolt
5/16"-18 x 1-3/4"
GR-5 ZINC

8x  # 90-212 Hex Bolt
5/16"-18 x 1-1/4"
GR-5 ZINC





12x  # 94-132 Plusnut

12x  # 98-116 Flat Washer
5/16", O.D. 7/8"
ZINC





12x  # 98-122 Lock Washer
5/16"
ZINC

4x  # 98-157 Spacer
0.375" ID, x 1.0" OD x 0.25" LONG
NYLON

8x

	#90-212 Hex Bolt 5/16" x 1-1/4"
	#98-122 Lock Washer
	#98-116 Flat Washer
	#94-132 5/16" Plusnut

4x

	#90-011 Hex Bolt 5/16" x 1-3/4"
	#98-122 Lock Washer
	#98-116 Flat Washer
	#98-157 Spacers (QTY = GAP BETWEEN FLOOR AND END PANEL)
	#94-132 5/16" Plusnut

PHASE 1 – ASSEMBLY

1.2 SHELF ASSEMBLY

1.2.1 Attach both panels to the shelf trays.

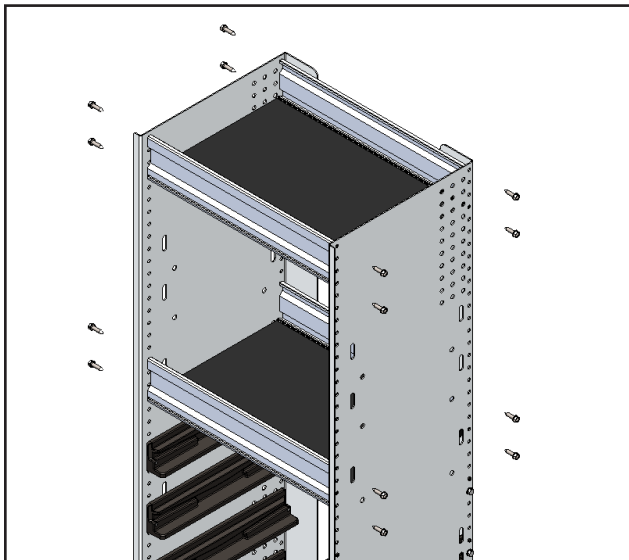
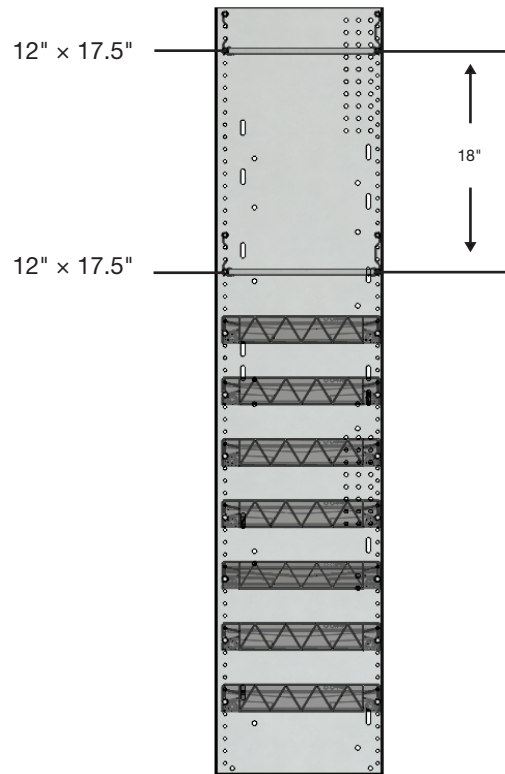
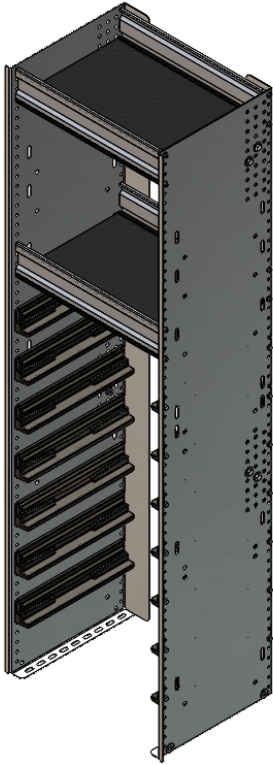

TOOLS

- Cordless Impact
- 3/8" Driver Bit

HARDWARE USED

16x 94-5023



#92-102 Screw #14 x 1"

1.2.2 Attach 2 bottom brackets to the end panels.

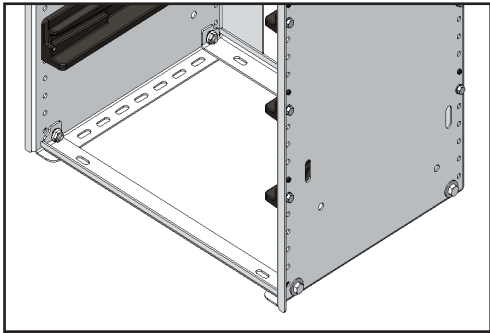
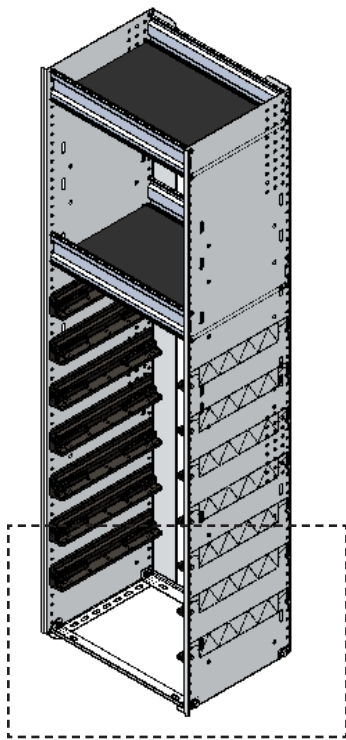



TOOLS

- Cordless Impact
- 1/2" Socket

HARDWARE USED

4x 94-5023

	#90-204 Hex Bolt 5/16" x 3/4"
	#98-116 Flat Washer
	#94-116 Serrated Nut

1.2.3 Attach 1 partskeeper rail on the bottom of each end panel.

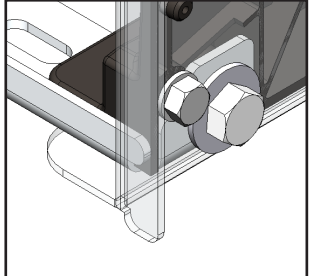
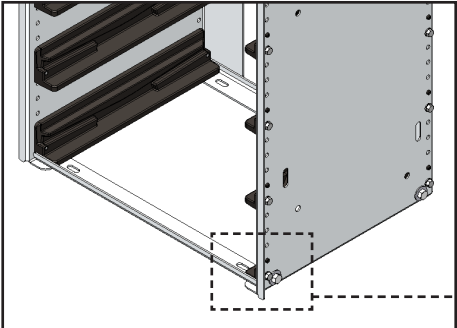
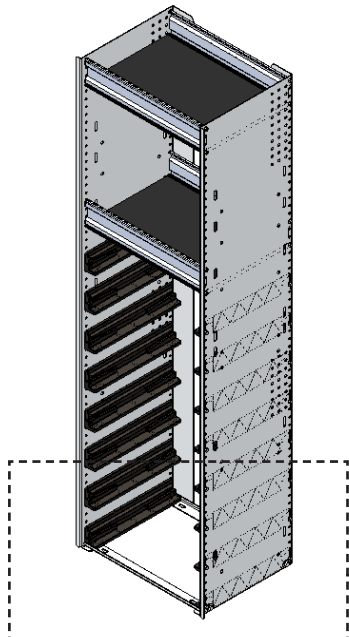

TOOLS

- Ratchet
- 3/8" Driver Bit

HARDWARE USED

4x 94-5023

	90-012 Screw 1/4"-10 x 3/4"
--	-----------------------------

PHASE 2 – INSTALLATION

2.1 ATTACH WALL BRACKETS TO THE END PANELS

IMPORTANT: For all **Box Trucks**, make sure that the shelving is securely fastened to the structure of the truck.

- 2.1.1**
- Lift the assembled partskeeper cabinet to the vehicle, then put it in place.
 - Attach the brackets to the panels aligning the brackets to the horizontal rim of the vehicle.

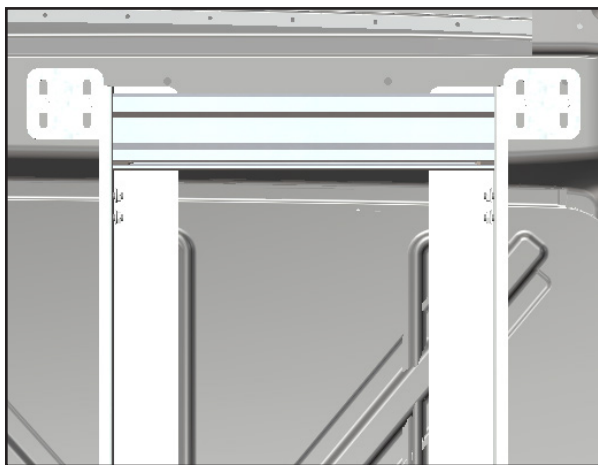
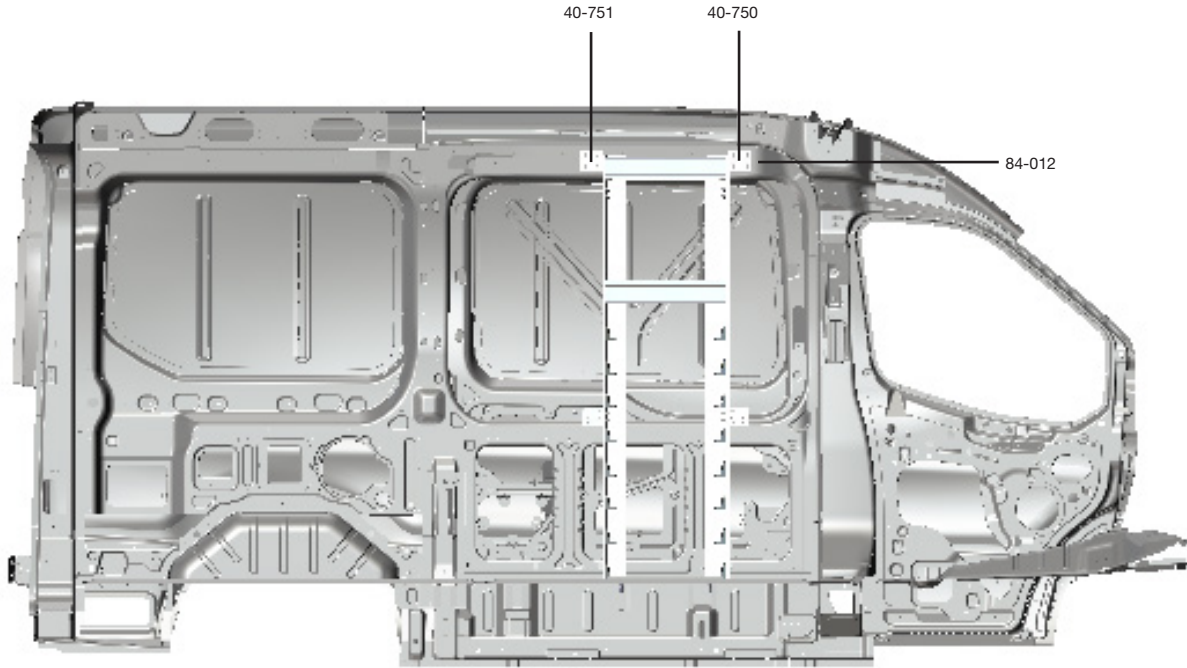



TOOLS

- Cordless Impact
- 1/2" Socket

HARDWARE USED

8x 94-5023

-  #90-204 Hex Bolt 5/16" x 3/4"
-  #98-116 Flat Washer
-  #94-116 Serrated Nut

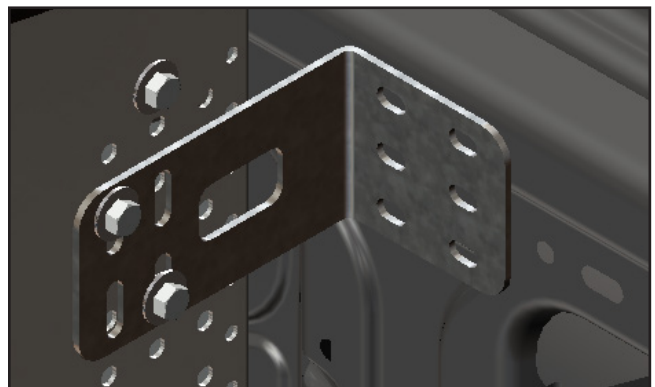

PHASE 2 – INSTALLATION

2.2 MARK HOLES FOR PLUS NUTS

2.2.1 After attaching the brackets mark the holes on the brackets and bottom shelf to the vehicle.

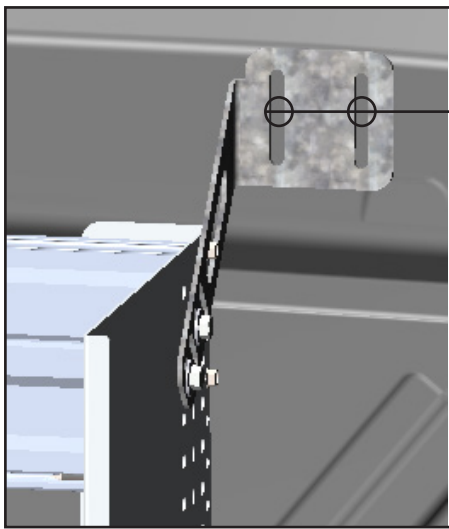
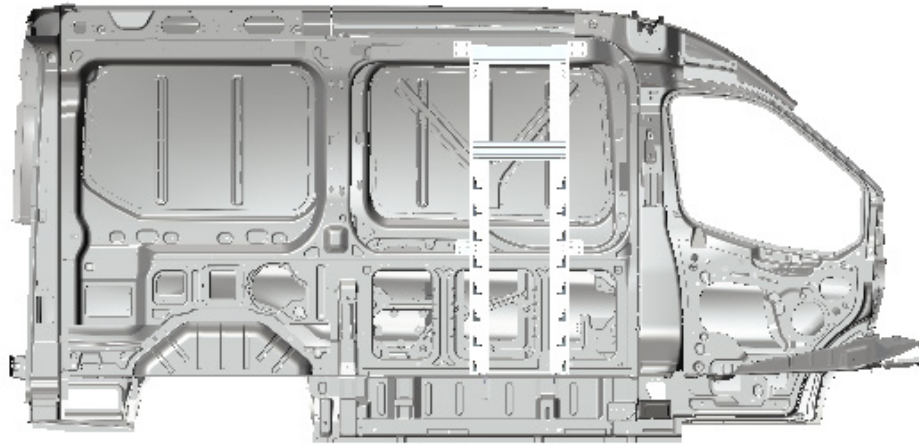

Mark 8 holes of the brackets on the vehicle as shown on the image.

NOTE: If you are using Ranger wall kits, please go to **PAGE 13**.

TOOLS

- Marker

MARK

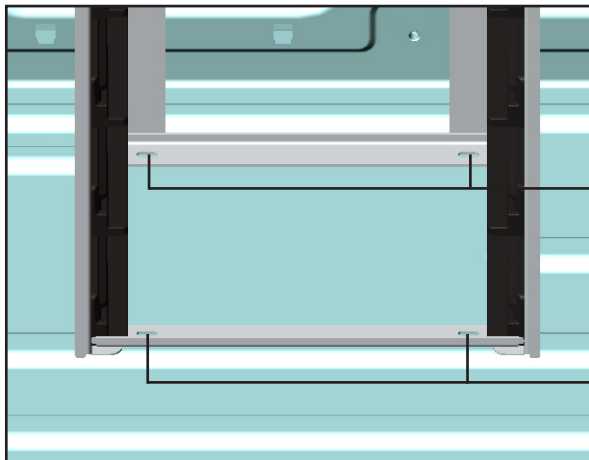
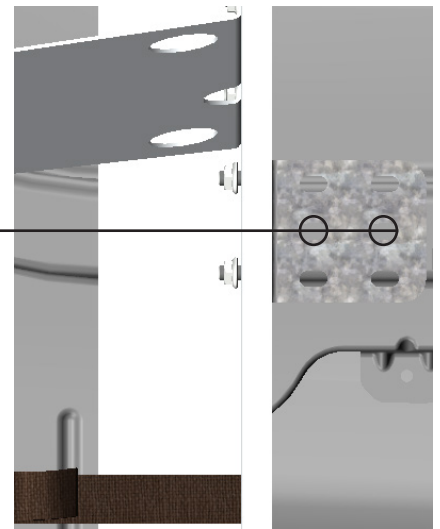

Mark the 2 holes of each floor bracket on the vehicle floor.

NOTE: If you are using Ranger floor, please go to **PAGE 12**.

TOOLS

- Marker

MARK

PHASE 2 – INSTALLATION

2.3 ATTACH PLUS NUTS

- 2.3.1**
- Lift the assembled partskeeper cabinet on the side.
 - Drill all the marks using 1/2" drill bit w/ drill collar, then attach plus nuts to the holes.

NOTE: Use 1/2" drill bit with drill collar to stop drill at 1/2" depth.

WARNING: Before drilling, ensure that you will not hit any critical parts of the vehicle like the **Gas tank, Wiring Harness and Hose.**

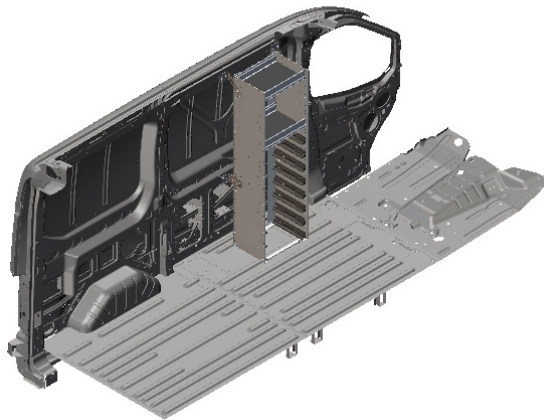

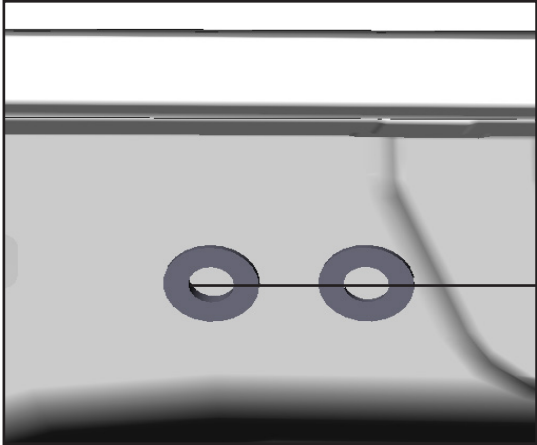

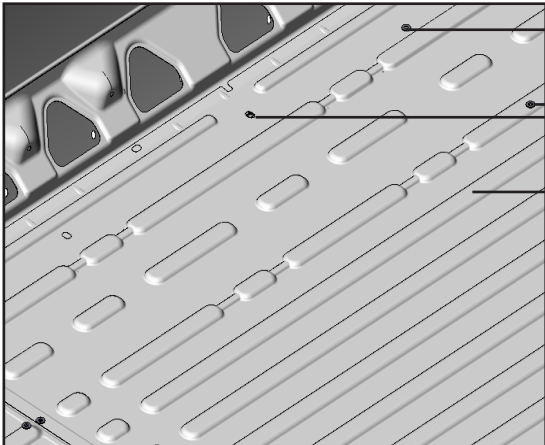

PLUSNUT

Drill all the marks then, attach plus nuts to the holes.

TOOLS

- ☐ Cordless Drill
- ☐ 1/2" Drill Bit w/ Drill Collar (Set at 1/2")
- ☐ Plus Nut Tool (5/16")

HARDWARE USED

12x 96-5023



#94-132 Plus Nut



DRILL COLLAR
(SET AT 1/2")

2.3.2 How to attach plus nut.

• USING PLUSNUT GUN

STEP: Put the plusnut on the plusnut gun, then attach the plus nut in the hole by turning the gun forward until the plus nut locks, then remove the gun by turning in reverse.

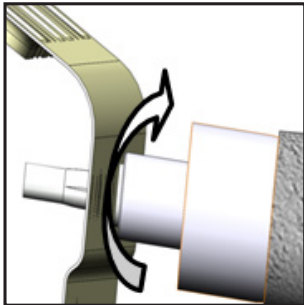

FORWARD

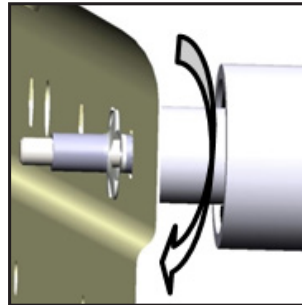

REVERSE

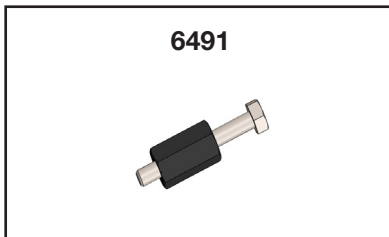

• USING THE 6491 PLUSNUT TOOL

NOTE: The hardware used for the 6491 plusnut tool is not included in the fastener bag. The 6491 plusnut tool can be ordered separately upon demand at no charge.



6491

HARDWARE USED

-  Flat washer 5/16"
-  Flat washer 5/16" BS x 7/8" OD

TOOLS

- Cordless Impact
- 1/2" Socket
- 9/16" Wrench

STEP 1:

Assemble the 6491 plusnut tool with the hardware needed, plus nut and the 9/16" wrench as shown.



STEP 2:

Attach the plus nut in the hole by turning the bolt forward using an impact with a 1/2" socket until the plus nut locks, then remove the bolt by turning the impact in reverse.

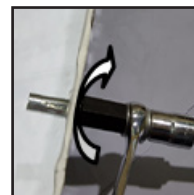

FORWARD



REVERSE

PHASE 2 – INSTALLATION

2.4 ATTACH PARTSKEEPER CABINET UNIT TO THE FLOOR

WITHOUT RANGER FLOOR

2.4.1 Put the assembled partskeeper cabinet back in place aligning the holes to the plusnuts, then install the bottom shelf to the plus nuts.

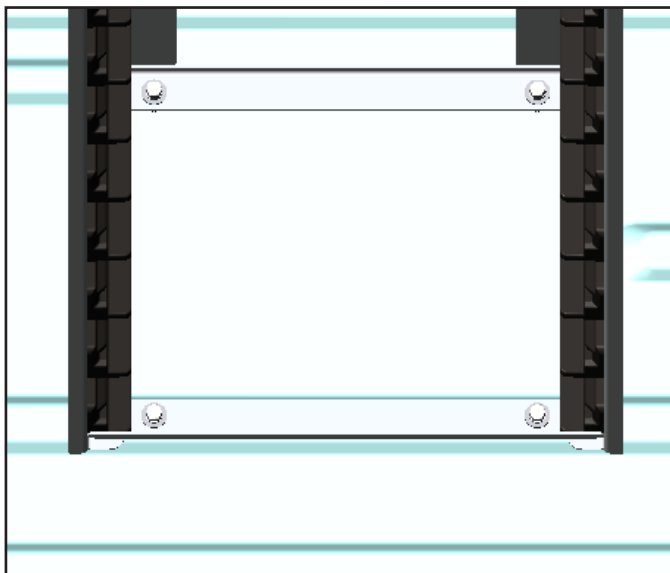
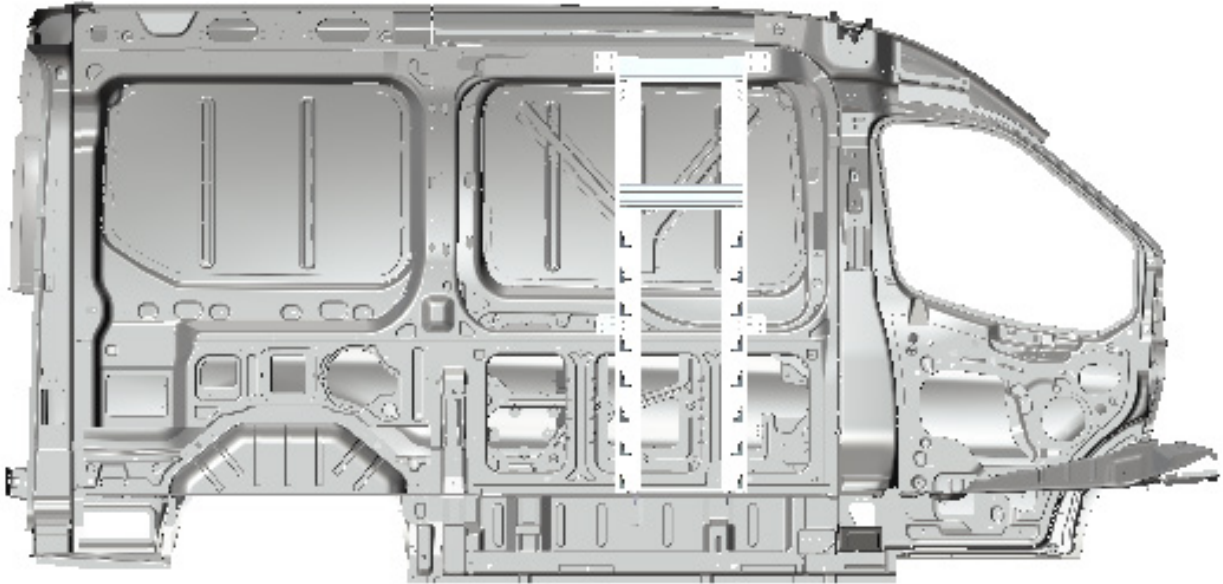

TOOLS

- Cordless Impact
- 1/2" Socket

HARDWARE USED

4x 96-5023



#90-011 Hex Bolt 5/16" x 1-3/4"



#98-122 Lock Washer



#98-116 Flat Washer



#98-157 Spacers

(QTY = GAP BETWEEN FLOOR AND END PANEL)



#94-132 5/16" Plusnut

WITH RANGER FLOOR

- 2.4.2**
- Lift the partskeeper cabinet inside the van, then put it in place.
 - Mark the 2 holes of each floor bracket, then place the partskeeper cabinet on the side.
 - Drill the marks on the floor using 1" hole saw, then drill holes into the van floor for plus nut.
 - Attach plus nut in the van floor, then lift the partskeeper cabinet back in place, and attach the floor bracket to the plus nut.

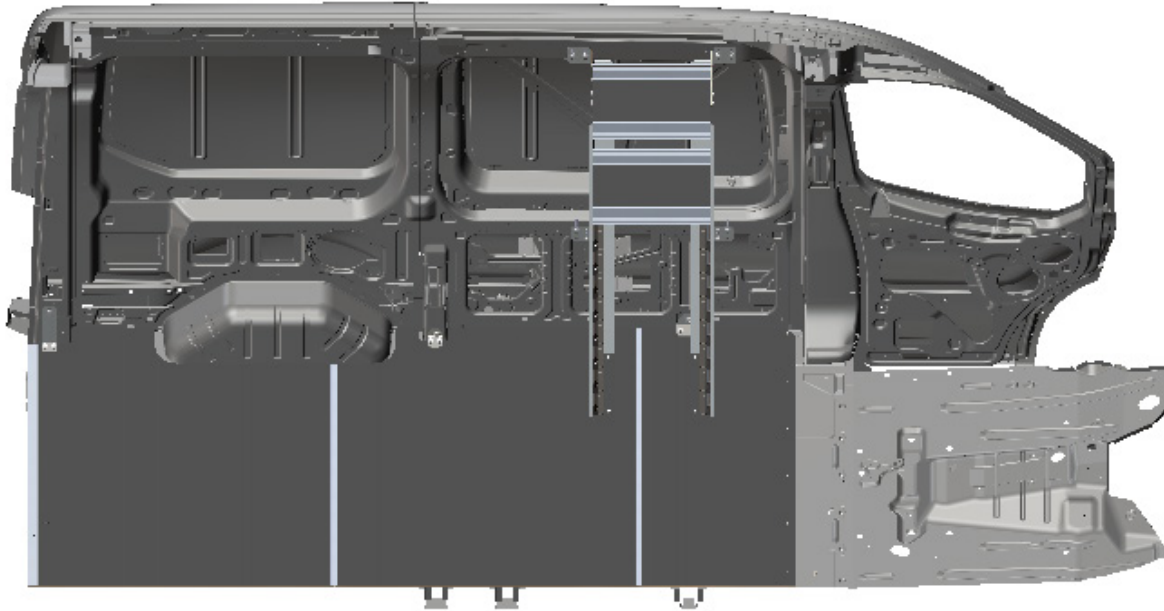

STANDARD FLOOR

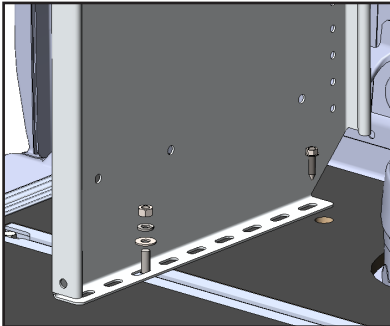

TOOLS

- Cordless Impact
- 3/8" Driver Bit
- 1/2" Socket

HARDWARE USED

2x FLOOR FASTENER KIT



#92-102 Screw 1"

HARDWARE USED

2x FLOOR FASTENER KIT



#90-490 Carriage Bolt 5/16" x 1"



#98-122 Flat Washer



#98-116 Lock Washer



#94-104 Hex Nut

E-FLOOR

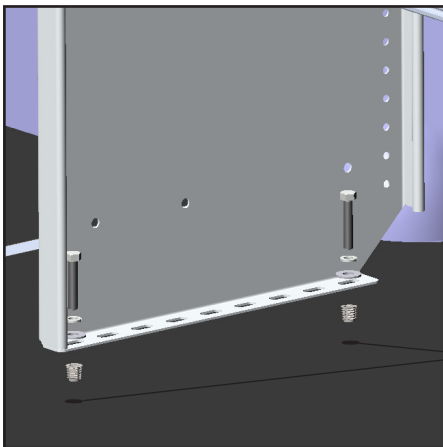

7/16 drill hole

TOOLS

- Marker
- 7/16" Drill Bit
- 1/2" Socket
- Drill Collar

HARDWARE USED

4x HAND-TIGHTEN THE BOLTS



#90-204 Hex Bolt 5/16" x 3/4"



#98-116 Lock Washer



#98-116 Flat Washer



#99-114 Zinc Alloy Tapping Inserts for Softwood

PHASE 2 – INSTALLATION

2.5 ATTACH WALL BRACKETS

WITHOUT RANGER WALL KITS

2.5.1 Align the wall brackets to the plus nuts, then install the wall brackets to the wall.

NOTE: Tighten the bolts that attach the bracket to the wall or wall rails 1st before tightening the bolts from the brackets to the end panels.

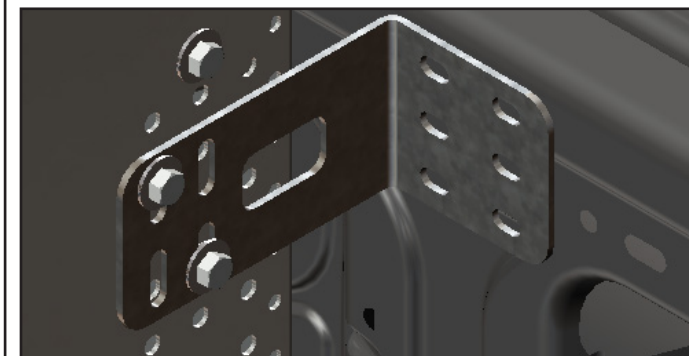
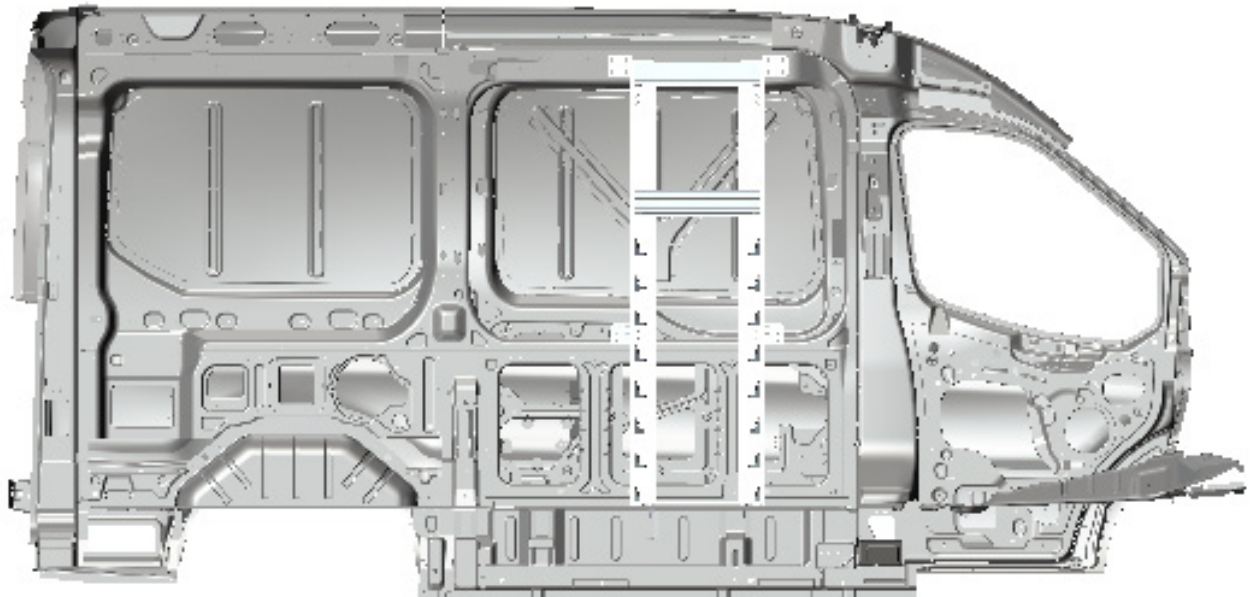

TOOLS

- Cordless Impact
- 1/2" Socket

HARDWARE USED

8x 96-5023



#90-212 Hex Bolt 5/16" × 1-1/4"

#98-122 Lock Washer

#98-116 Flat Washer

#94-132 5/16" Plusnut

WITH RANGER WALL KITS

2.5.2 First align the wall brackets to the wall mounting track kits, then install the wall brackets to the wall mounting track kits using channel nuts.

IMPORTANT: First tighten the bolts that secure the wall bracket to the wall or wall kits, and then tighten the bolts that secure wall bracket to the end panels. After installation is completed, ensure all bolts are properly tightened.

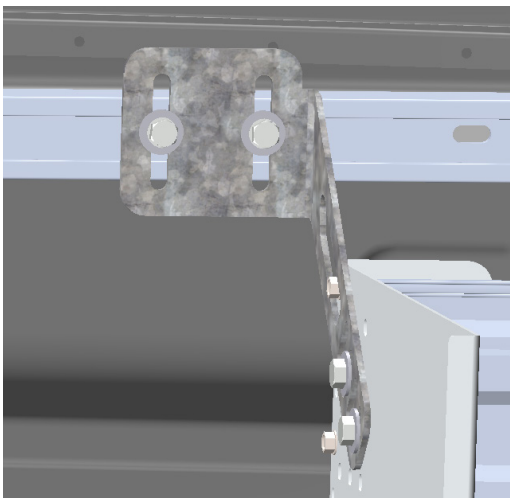
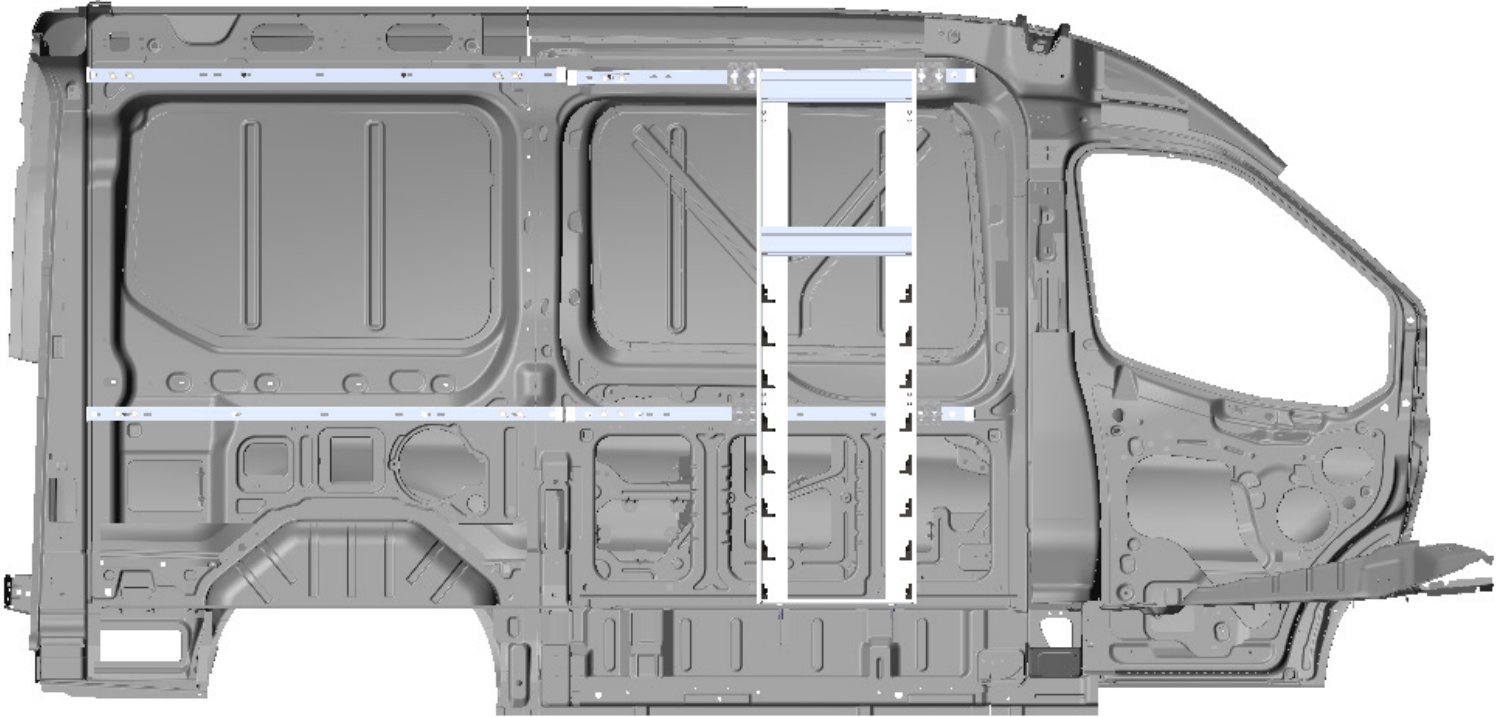

TOOLS

- Cordless Impact
- 1/2" Socket

FASTENERS USED

8x WALL KITS FASTENER KIT

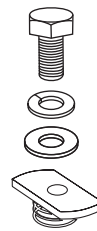

#90-208 Hex Bolt 5/16" x 1"

#98-122 Lock Washer

#98-116 Flat Washer

#94-150 Channel Nut

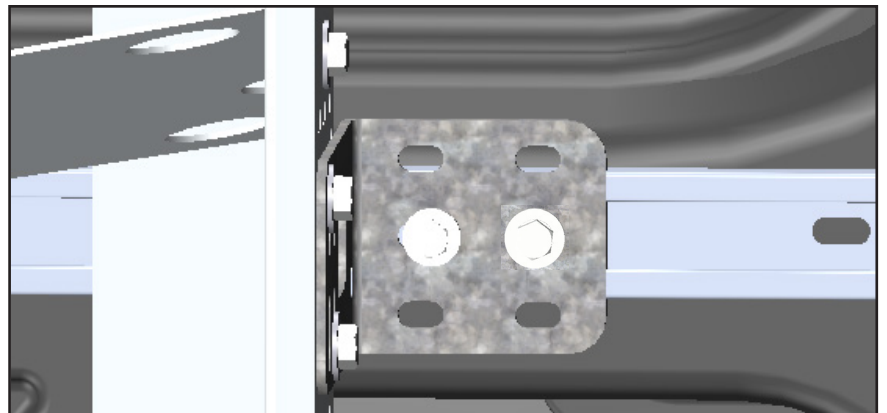

IMPORTANT: After checking all bolts are tightened slide 8 partskeeper case to the cabinet.

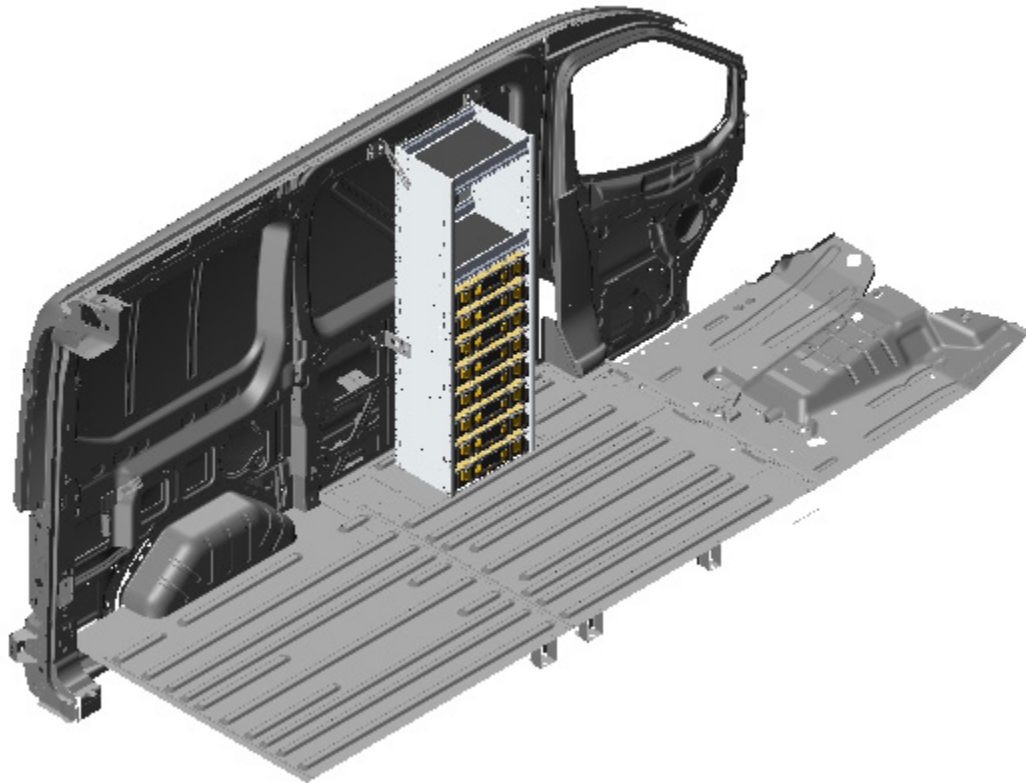

**“You have successfully installed your
C5-PA18-8C**

Thank you for doing business with us.”

For any feedback or suggestions you may have, please contact: cs@rangerdesign.com

