

Owner's Manual

BDW-Series

This Owner's Manual provides assembly, install and user guidance. It applies to all **BDW Series Truck Box** sold by Ranger Design. For a list of compatible models, visit our website at rangerdesign.com.

Contents

Warnings	2
Parts Included	3
Hardware	4
Tools Required (Not Included)	4
Installation	5

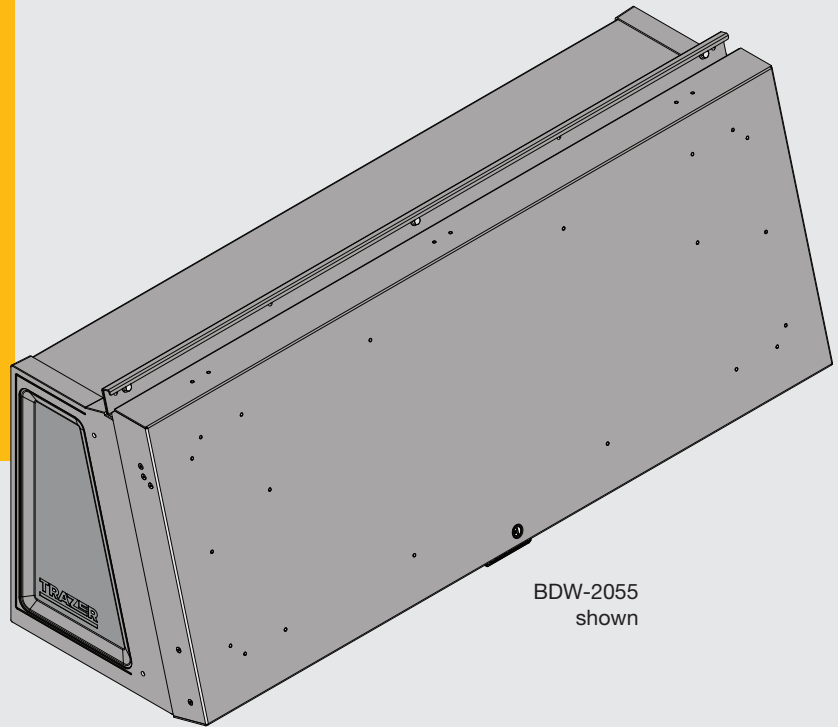

BDW-2055
shown



Scan the QR code for the latest Installation Guide. For more information, visit rangerdesign.com.



Warnings

READ, UNDERSTAND, AND FOLLOW ALL WARNINGS AND INSTRUCTIONS BEFORE USING THIS PRODUCT. FAILURE TO FOLLOW THESE DIRECTIONS MAY RESULT IN PROPERTY DAMAGE, SERIOUS BODILY INJURY, AND/OR DEATH. RANGER DESIGN IS NOT RESPONSIBLE FOR ANY PROPERTY DAMAGE, PERSONAL INJURY, OR DEATH THAT OCCURS WHILE USING ANY RANGER DESIGN PRODUCTS.

THE FINAL ALTERER AND/OR MODIFIER SHOULD REVIEW THE WARNING SHEET WITH THE CUSTOMER BEFORE THE VEHICLE IS RELEASED TO THE CUSTOMER FOR GENERAL USE. THESE INSTRUCTIONS SHOULD REMAIN WITH THE VEHICLE AT ALL TIMES.

WARNINGS – Prior To Starting

- Ranger Design products must be assembled and installed by individuals qualified to use the tools required and have experience with similar products. If there is any question as to competence or experience, please contact a professional alterer or modifier.
- Failure to use Ranger Design-provided fasteners, brackets, and proper installation guidelines could increase risk of serious personal injury and/or death.
- Prior to installation, inspect the vehicle to ensure that installation will not interfere with, or cause obstruction of, any critical components such as electrical wiring, fuel tanks, fuel cells, locks, latches, airbags, cameras, lights, sensors, mirrors, etc.
- The final alterer and/or modifier is responsible for ensuring all equipment is sufficiently secured to the vehicle.
- Do not install systems into any weak or unsound materials such as plastics, woods, thin-walled metals, etc., without proper reinforcement.
- Incorrect installation could cause water leaks, electric shock, or fire.
- Any modification or unintended use of this product voids any warranty and could create a hazardous condition.
- Ranger Design provides recommended assembly and installation instructions which must be followed to ensure correct operation. Failure to do so could invalidate the product's compliance and/or warranty and cause injury.
- The final stage vehicle alterer and/or modifier is responsible for the integration, installation, and compliance of the product in its final location with all applicable regulations and standards. Failure to maintain compliance of the vehicle with applicable regulations and standards could be punishable by law. Alterers and/or modifiers should consult with all local authorities prior to commissioning.

WARNINGS – Prior To Drilling

- Wherever possible, secure to existing Original Equipment Manufacturer's (OEM's) mounting points. Consults the vehicles OEM documentation for load limits of each attachment point.
- Improper drilling can cause property damage to vehicles and could lead to electric shock, fire, or even death.
- Ensure that drilling is only performed on areas of the vehicle allowed by the vehicle's OEM's Body Builders Layout Book (or equivalent document).

- Ensure that you will not hit any critical parts of the vehicle like the gas tank, wiring harnesses, or hoses. Consult the vehicle's OEM documentation as necessary. When drilling, use a drill collar to reduce the risk of damage to the vehicle.
- After drilling, ensure holes are sealed in accordance to the original vehicle manufacturer instructions.

WARNINGS – Prior To Operating Vehicle

- Ensure the weight of the cargo is correctly distributed to reduce negatively impacting the vehicle stability and handling. The heaviest items must be placed low in the vehicle, while the lighter items can be placed on a rack higher up.
- Operator must adapt speed to the conditions of the road, the wind, the weather, and the load being carried.
- Respect the maximum weight capacity of the Ranger product as defined in your operator's manual.
- Check your vehicle's tare weight and remaining load capacity with all equipment installed. Never exceed the maximum Gross Vehicle Weight Rating (GVWR), Gross Axle Weight Ratings (GAWRs), roof load limit, bed rail capacity, or other maximum loads permitted by the vehicle's Original Equipment Manufacturer (OEM) and required by law.
- All cargo should be properly secured while the vehicle is in motion.
- All system components should be regularly inspected for damage, corrosion, fractures, loose parts, loose fasteners, etc. pursuant to Ranger Design guidelines. Damaged components must be replaced and loose component tightened prior to operating the vehicle.
- All system components should be regularly cleaned and maintained pursuant to Ranger Design guidelines.

WARNING – In Event Of An Accident

- In the event of a motor vehicle accident or collision where a Ranger Design system has been installed, especially ones where the vehicle's structure has been damaged and/or the air bags have deployed and/or the vehicle has been towed, the system must be inspected to ensure continued soundness and safety before returning the vehicle to service. Damaged components should be replaced as necessary.

FR: Si vous avez besoin de ces instructions en français, s'il vous plait contacter notre service à la clientèle. +1-800-565-5321

ES: Si necesita estas instrucciones en español, comuníquese con el Servicio de atención al cliente de Ranger Design. +1-800-565-5321

Parts Included

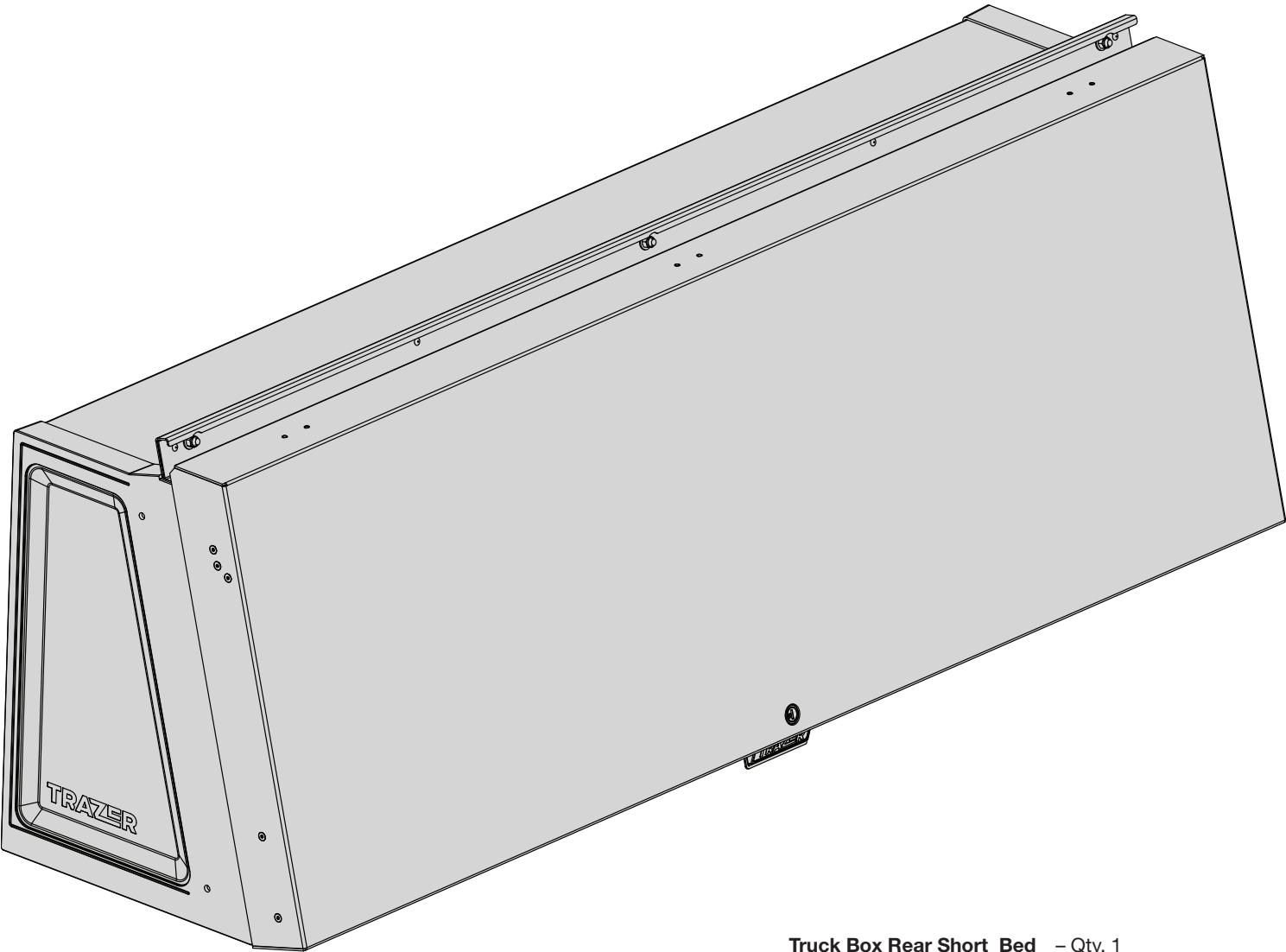



Truck Box Rear Short Bed – Qty. 1
P/N BDW-2055

OR

Truck Box Standard Bed – Qty. 1
P/N BDW-2065

Hardware

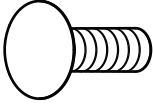
Assembly Fastener Kit Content

Part	P/N & Description	P/N 96-2003 Qty.
	P/N 90-491 Carriage Bolt 5/16"-18 x 1" SS 304	3
	P/N 94-111 Nut Lock 5/16"-18 SST	3
	P/N 98-117 Flat Washer 5/16"O.D 3/4" SST	3

Tools Required (Not Included)

- Measuring tape
- Ratchet
- 1/2" Socket
- 1/2" Wrench

Installation

BEFORE STARTING

- Verify that you have complete parts before starting.

Skip STEP 1 and STEP 2 proceed directly to STEP 3 if installing to a new truck rack.

STEP 1 Remove gussets.

- Uninstall the rear cross plate and set aside for later.
- Remove and discard top gussets and it's hardware.
- Uninstall the bolts completely from the rear upright and remove the bottom gusset. Discard short bolts and set aside 4-1/4" bolts for later.

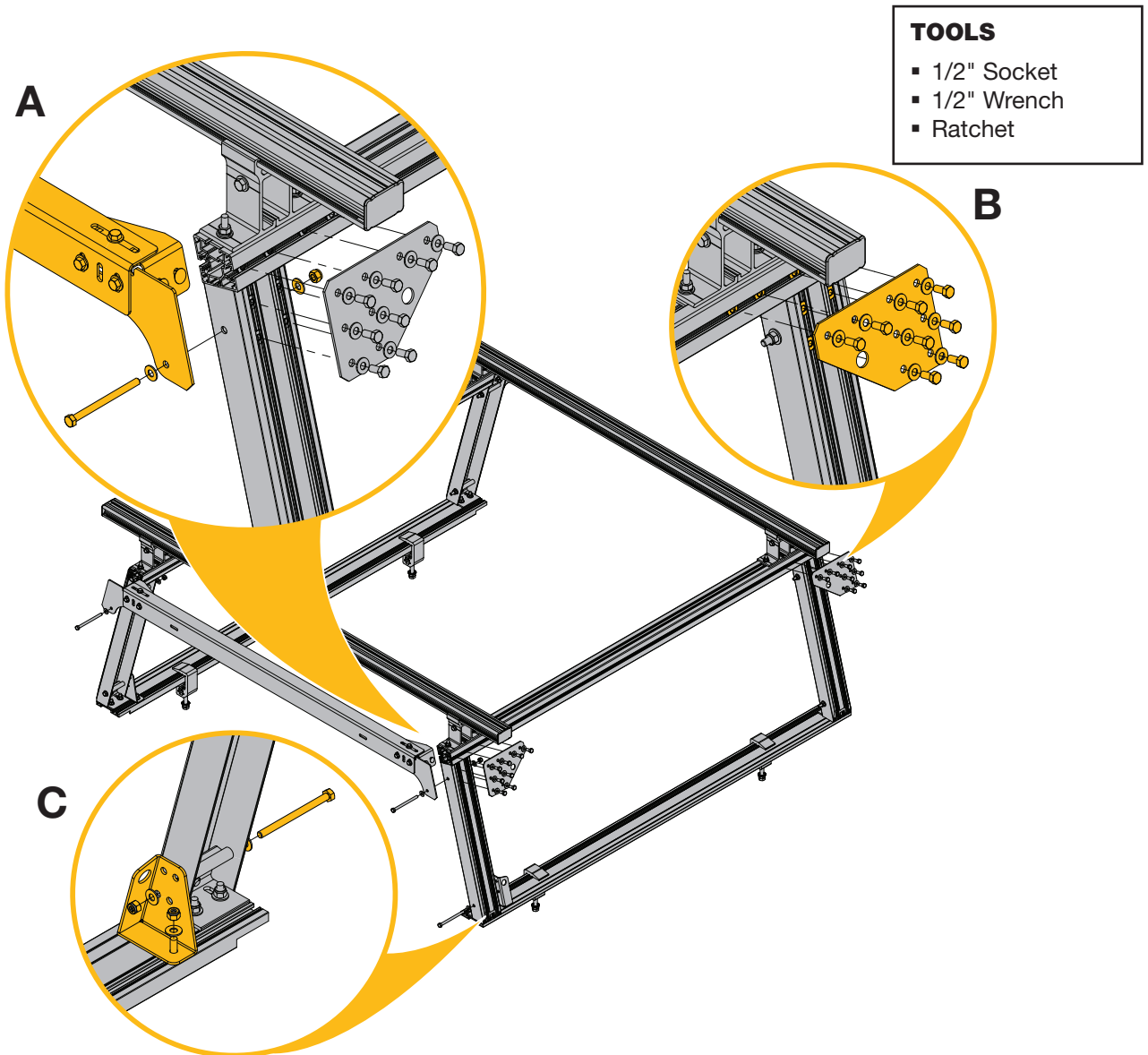

Installation

STEP 2 Remove rear cross brace and loosen uprights.

- a.** Loosen the bolts in the slots at the bottom of the rear upright.
- b.** Remove the bolts from the front upright until they are no longer protruding from the extrusion to allow for proper box installation.

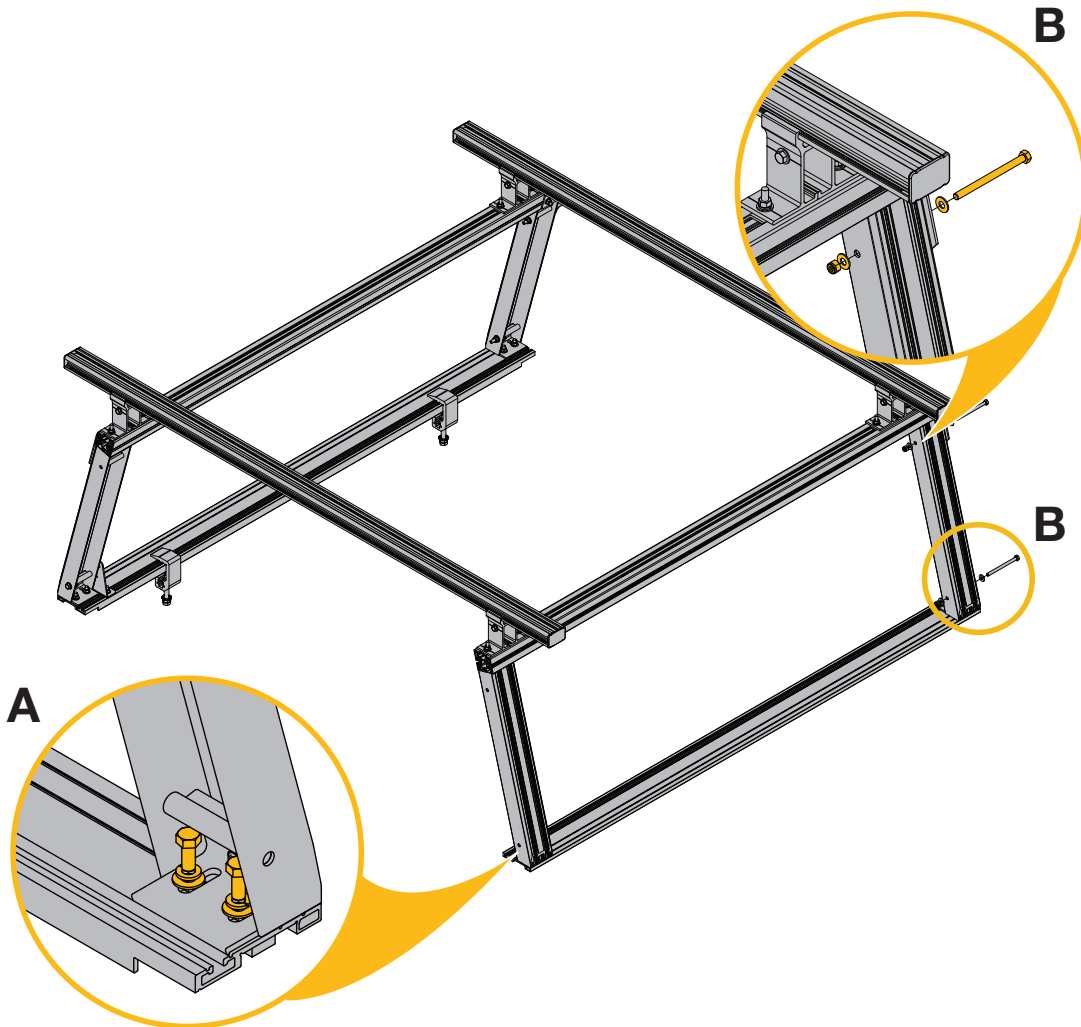

Installation

STEP 3 Insert the (3) carriage bolts into the channel in the transverse beam.

HARDWARE

Carriage Bolt

Qty: 3

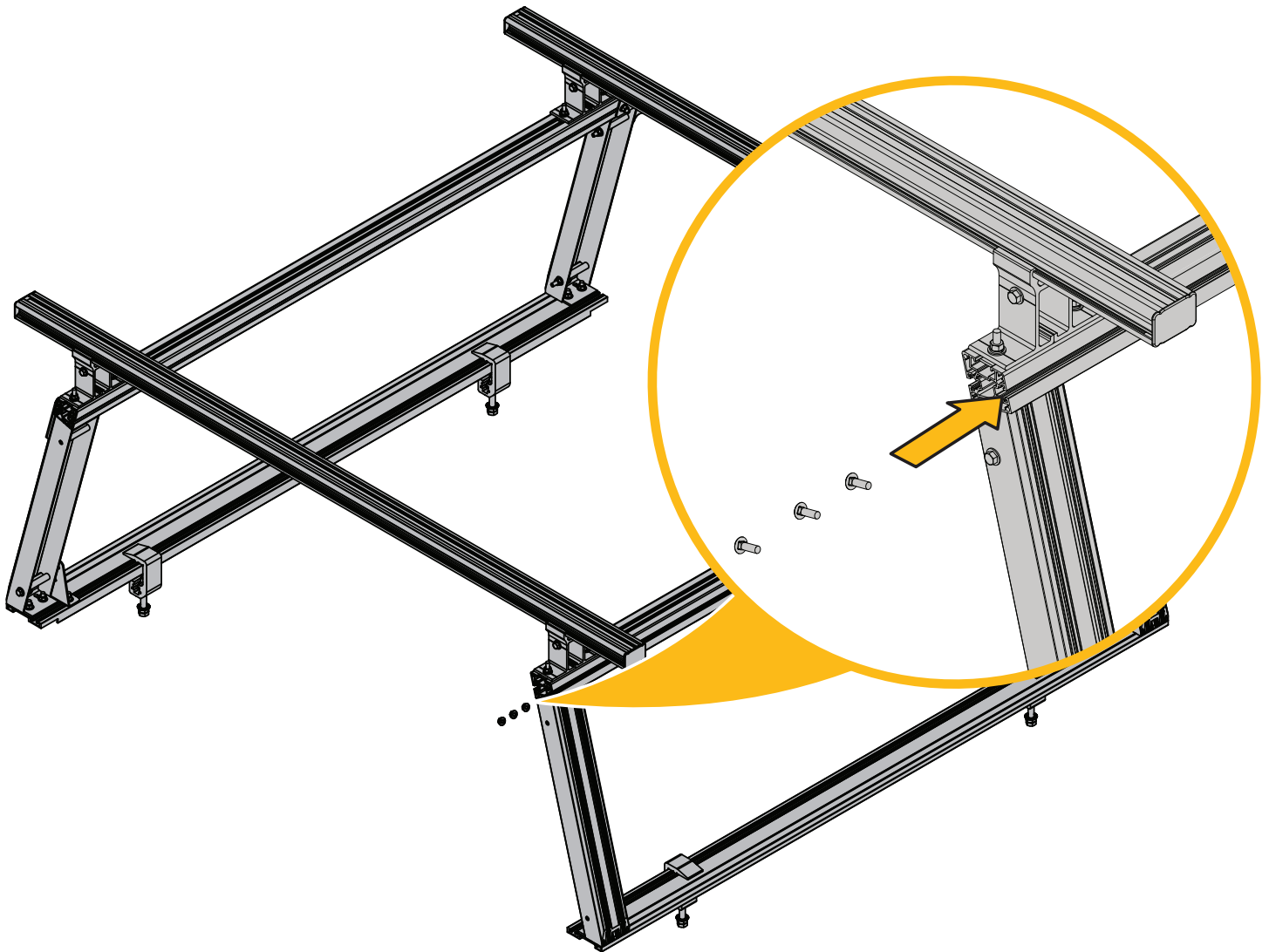

Installation

 **WARNING:** A minimum of 2 people are required for installing the box safely.

STEP 4 Insert box into rack opening.

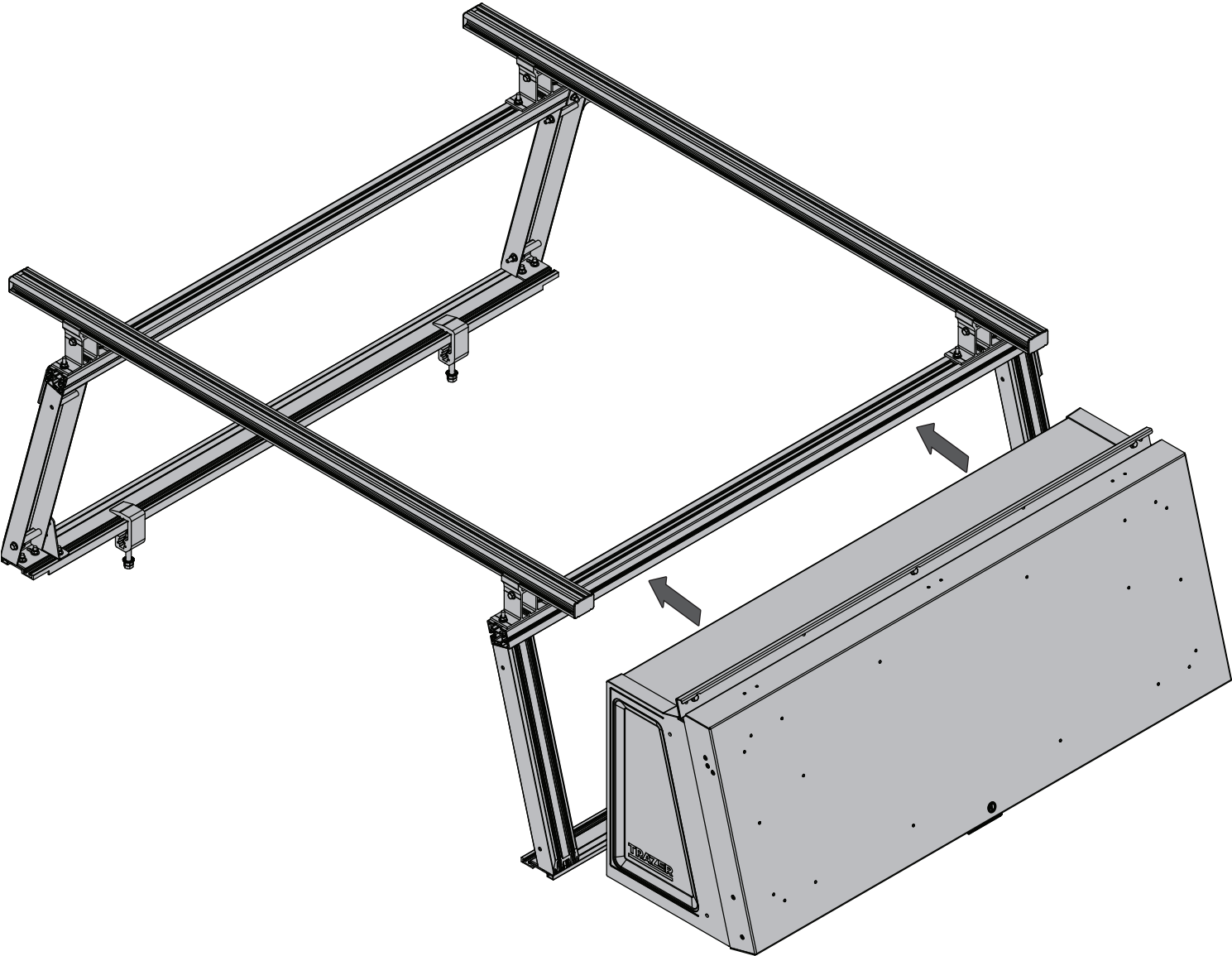

Installation

NOTE:

- Use Anti-seize provided with the rack when fastening bolt.
- The hardware used in this step is provided in the rack box and was removed and set aside in step 1 and 2.

STEP 5

Open the door, bolt side panels to rack uprights and reattach the rear cross plate.

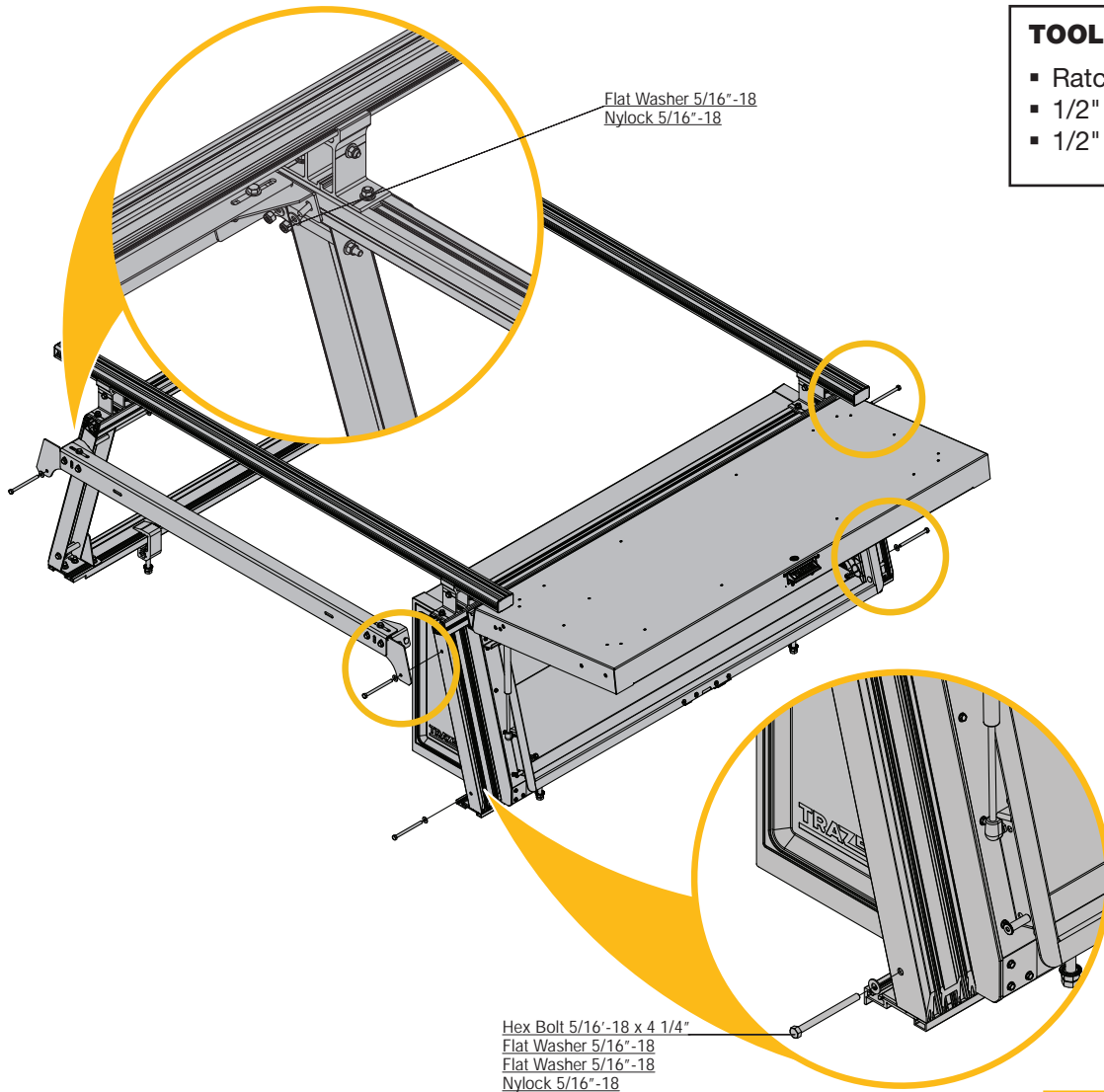

TOOLS

- Ratchet
- 1/2\" Socket
- 1/2\" Wrench



**Torque to
11 ft-lbs.**

Installation

NOTE:

- Use Anti-seize provided with the rack when fastening bolt.

STEP 6 Install the top of truck box.

- Install washer and nut lock with to hold in place while you place the rest of the hardware.
- Tighten them all in place.

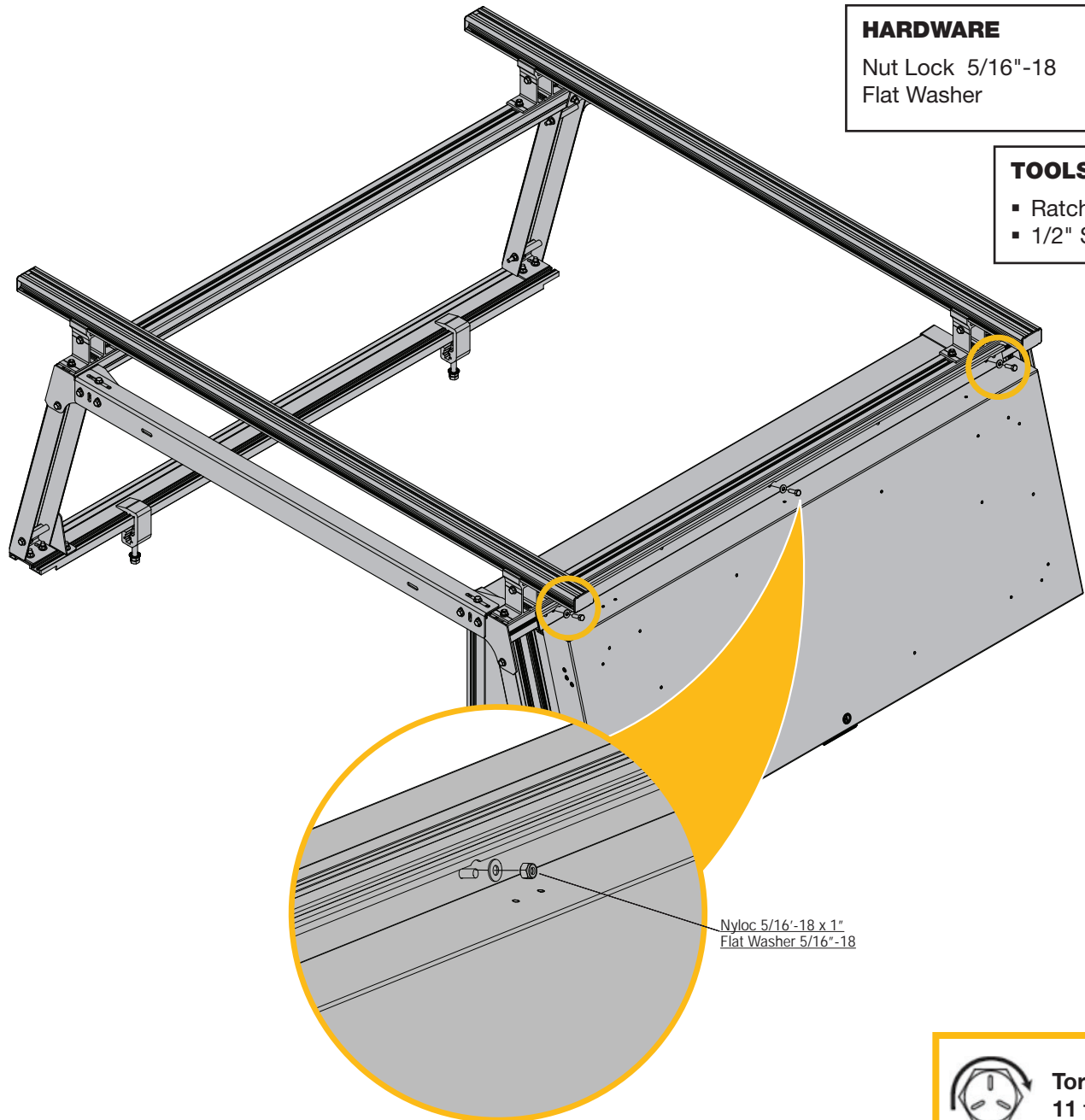

Installation

STEP 7 Re-tighten the rear uprights bolts in the slots.

TOOLS

- Ratchet
- 1/2" Socket
- 1/2" wrench

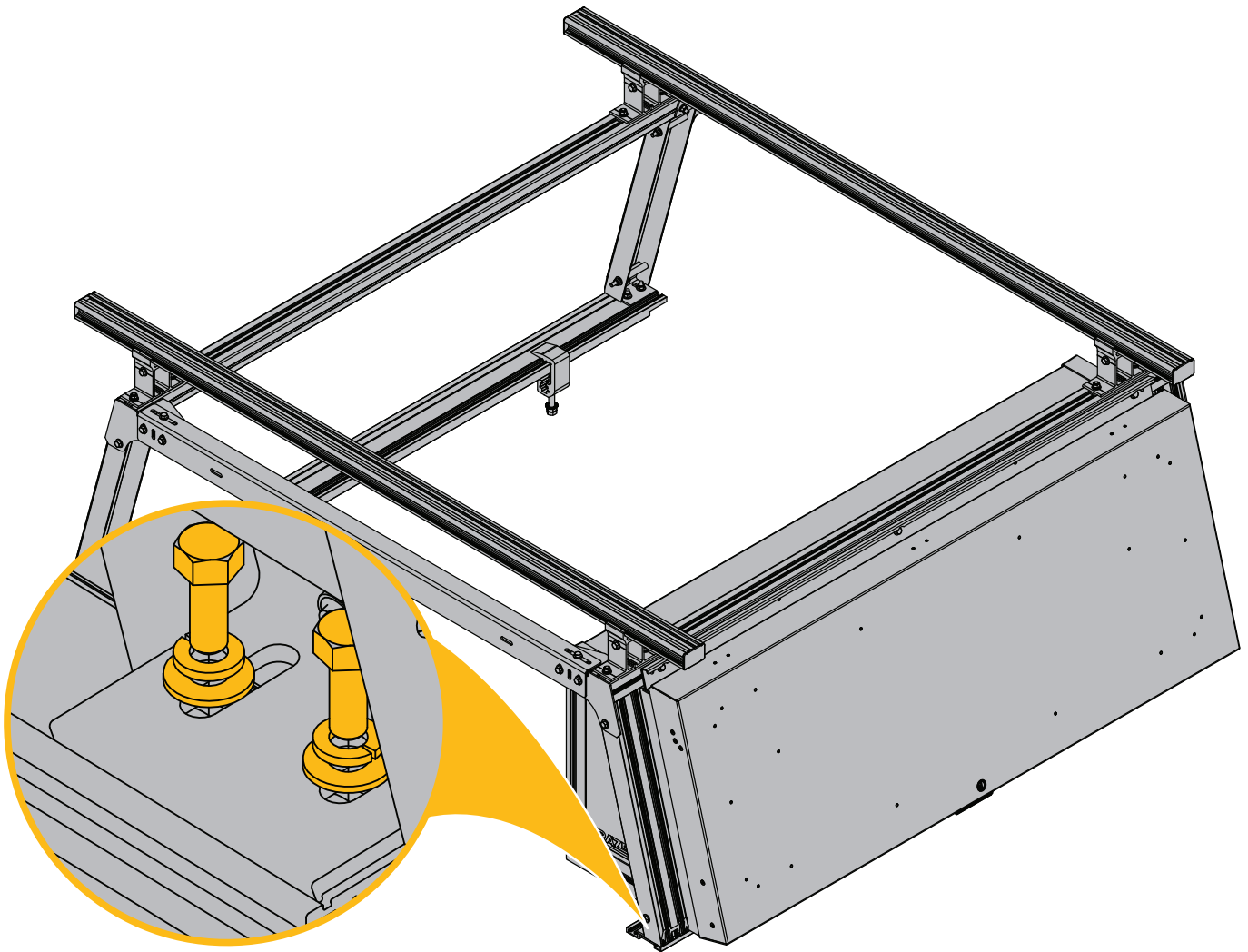

Torque to
11 ft-lbs.



You have successfully assembled and installed your BDW series.

Thank you for doing business with us.

For technical support, contact us at 1-800-565-5321.

For any feedback or suggestions you may have, please contact cs@rangerdesign.com.

Copyright © 2024

All rights reserved. This manual or any portion thereof may not be reproduced or used in any manner whatsoever without the express written permission of Ranger Design, Inc.