

INSTALLATION GUIDE

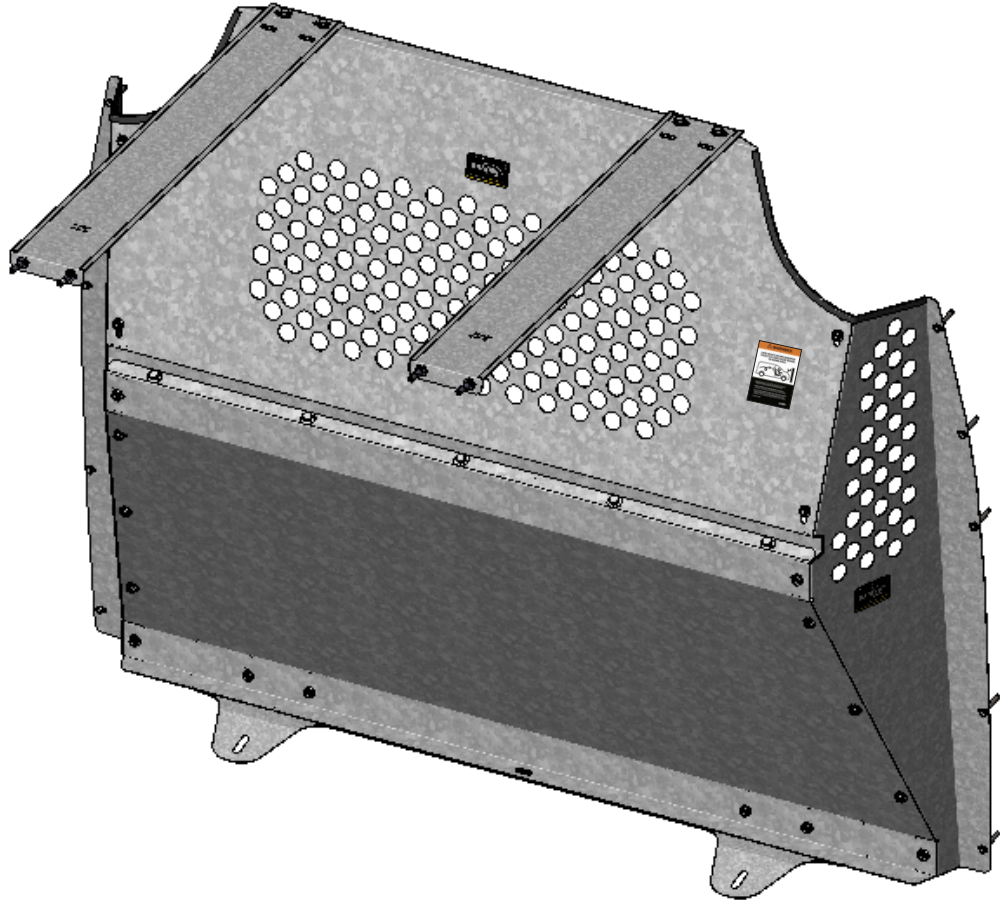

C10-E CONTOURED PARTITION

Transit Connect Partition (Perforated Window, Steel)

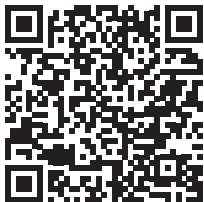

Scan the QR for the latest Install-Guide.





BEFORE YOU BEGIN

READ, UNDERSTAND, AND FOLLOW ALL WARNINGS AND INSTRUCTIONS BEFORE USING THIS PRODUCT. FAILURE TO FOLLOW THESE DIRECTIONS MAY RESULT IN PROPERTY DAMAGE, SERIOUS BODILY INJURY, AND/OR DEATH. RANGER DESIGN IS NOT RESPONSIBLE FOR ANY PROPERTY DAMAGE, PERSONAL INJURY, OR DEATH THAT OCCURRED WHILE USING ANY RANGER DESIGN PRODUCTS.



WARNING

- Failure to use Ranger Design-provided fasteners, brackets, and proper installation guidelines could increase risk of serious personal injury and/or death.
- If drilling is required to complete this installation: improper drilling can cause property damage to vehicles and could lead to electric shock, fire, or even death.
- If drilling is required to complete this installation: Ensure that drilling is only performed on areas of the vehicle allowed by the vehicle's Original Equipment Manufacturer's Body Builders Layout Book (or equivalent document).
- Prior to installation, inspect the vehicle to ensure that installation will not interfere with, or cause obstruction of, any critical components such as electrical wiring, fuel tanks, fuel-cells, locks, latches, etc.
- The installer or manufacturer is responsible for ensuring anchorages are installed onto suitable wall and floor structures; wall and floor strength must meet applicable performance requirements.
- Do not install systems into any weak or unsound materials such as plastics, woods, thin-walled metals, etc. without proper reinforcement.
- Do not install this product where it could interfere with the deployment of airbags. Failure to comply could result in death or serious injury.
- Do not install this product where it could ingress on the Transit Occupant Protection Zone. Failure to comply could result in death or serious injury.
- Incorrect installation could cause water leaks, electric shock or fire.
- Any cargo vehicle with any cargo or equipment should use a certified partition. See Ranger Design website for some partition options. (<https://rangerdesign.com/>)
- Mountings rails are recommended for any attachment to the vehicle walls.
- All items in the cargo area should be properly secured and partition doors closed while the vehicle is in motion.
- Check your vehicle's tare weight and remaining load capacity with all the equipment installed. Never exceed the maximum Gross Vehicle Weight Rating (GVWR), Gross Axle Weight Ratings (GAWRs), or other maximum loads permitted by the vehicle's Original Equipment Manufacturer (OEM) and required by law.
- The heaviest items must be placed towards the bottom of the vehicle, while the lightest ones can be arranged upwards. Vehicle cargo loading weight proportion should follow the following guidelines:

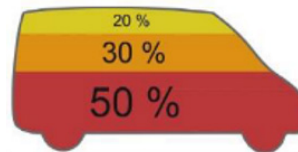

- The final alterer and/ or modifier should review the warning sheet with the customer before the vehicle is released to the customer or for general use. These instructions should remain with the vehicles a all times.
- Any modification or unintended use of this product voids any warranty and could create a hazardous condition.
- Ranger Design provides recommended assembly and installation instructions which should be followed to ensure correct operation. Failure to do so could result in invalidating the product's compliance, warranty and cause injury. Notwithstanding, the final stage vehicle alterer and/or modifier is responsible for the integration, installation, and compliance of the product in its final location to all applicable regulations and standards. Failure to maintain compliance of the vehicle to applicable regulations and standards could be punishable by law. Alterers and/or modifiers should consult with all local authorities prior to commissioning.



CAUTION

- Drilling is required to complete this installation. Before drilling, ensure that you will not hit any critical parts of the vehicle like the gas tank, wiring harness, or hose. Consult the vehicle OEM documentation as necessary. When drilling, use a drill collar to reduce the risk of damage to the vehicle.
- Any materials, padding, or glazing installed in the vehicle must comply with FMVSS/CMVSS 201/205/302, as applicable.
- In the event of a motor vehicle accident or collision where a Ranger system has been installed, especially ones where the vehicle structure is damaged and/or the air bags deploy and/or the vehicle has been towed, the system must be inspected to ensure continued soundness and safety before returning the vehicle to service. Damaged components should be replaced as necessary.
- All system components should be regularly inspected, cleaned, and maintained pursuant to Ranger guidelines.

QUICK START GUIDE

Phase 1 - Assembly

<input type="checkbox"/> 1.1 Setup.....	4
<input type="checkbox"/> 1.2 Partition Assembly.....	6

Phase 2 - Installation

<input type="checkbox"/> 2.1 Tips On How To Attach a Plusnut.....	8
<input type="checkbox"/> 2.2 Vehicle Preparation.....	9
<input type="checkbox"/> 2.3 Contoured Partition Installation.....	11

REQUIRED ITEMS

- Cordless Impact
- Cordless Drill
- Cutter
- Knife
- Mallet
- 1/2" Socket
- 7/16" Socket
- 10mm Socket
- T50 Torque Bit
- 9/16" Wrench
- 9/64" Drill Bit

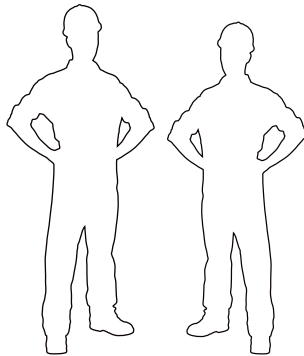

2
PERSONS

PHASE 1 – ASSEMBLY

1.1 SETUP

1.1.1 Unpack components; compare with the bill of materials.

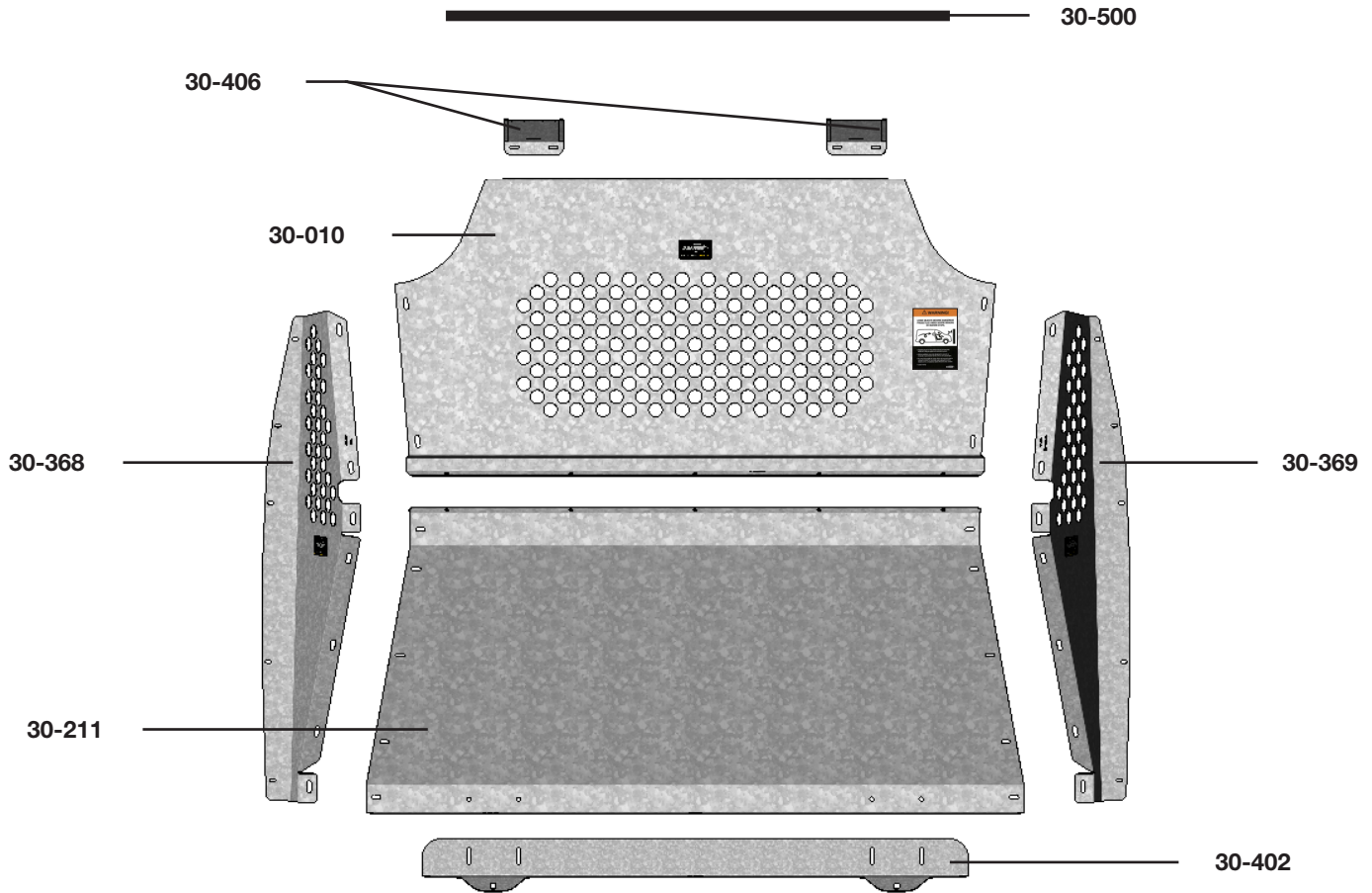

1.1.2 Verify all parts are present

Item No.	Description	Qty.
30-010	Upper Perforated Panel	1
30-211	Lower Panel	1
30-368	Driver Side Wing	1
30-369	Passenger Side Wing	1
30-406	Ceiling Bracket	2
30-402	Floor Bracket	1
30-500	Edge Trim (QTY in Inches)	34.75
79-932	Warning Label (Bilingual)	1
94-3024	Assembly Fastener Bag	1
96-3014	Installation Fastener Bag	1

1.1.3 Identify the **94-3024** and **96-3014** fastener bags.

94-3024 Fastener Kit

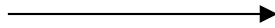

Fastener Assembly

4x		# 90-108	Hex Bolt 1/4"-20 x 5/8" ZINC
19x		# 90-200	Hex Bolt 5/16"-18 x 1/2" ZINC
4x		# 90-204	Hex Bolt 5/16"-18 x 3/4" ZINC
4x		# 94-112	Serrated Nut 1/4"-20 ZINC
23x		# 94-116	Serrated Nut 5/16"-18 ZINC
4x		# 98-112	Flat Washer 1/4", 3/4" OD ZINC
23x		# 98-116	Flat Washer 5/16", 7/8" OD ZINC

4x

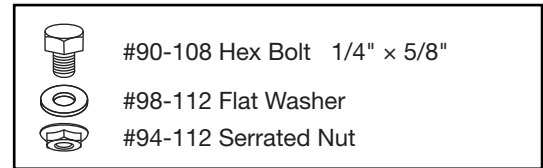

19x

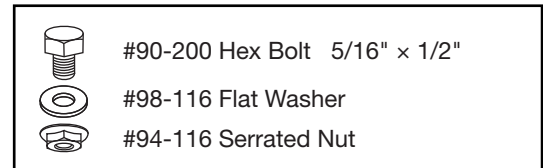

4x

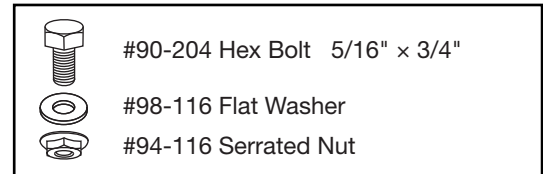

96-3014 Fastener Kit

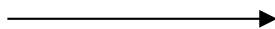

Fastener Assembly

4x		# 90-118	Hex Bolt 1/4"-20 x 1-1/4" GR-5 ZINC
4x		# 94-130	Plusnut .250
4x		# 98-112	Flat Washer 1/4", 3/4" OD ZINC
4x		# 98-118	Lock Washer Regular 1/4" ZINC
10x		# 90-971	Self-Tapping Screw M6-1.0 x 20mm 1022 BO

4x



10x



PHASE 1 – ASSEMBLY

1.2 PARTITION ASSEMBLY

1.2.1 Remove all the PVC from all the parts, then attach the upper panel to the lower panel.

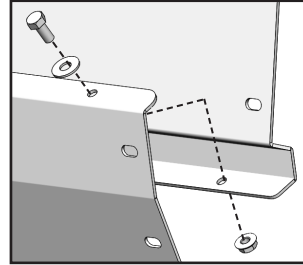
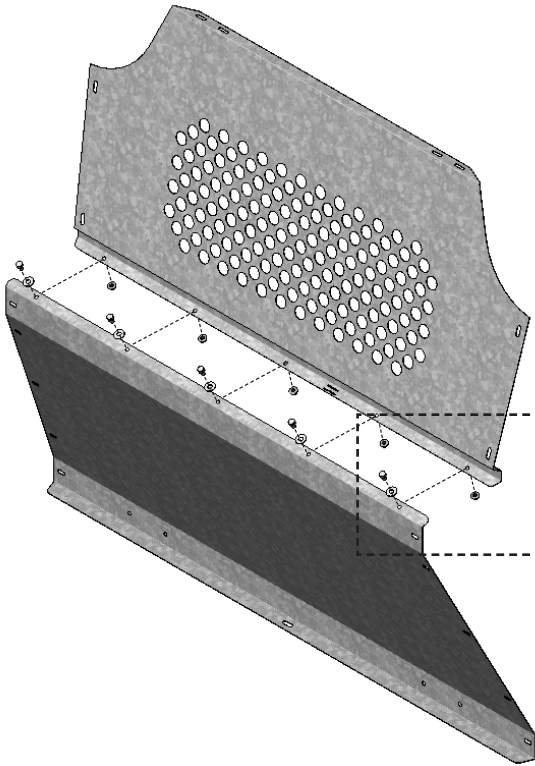



TOOLS

- Cordless Impact
- Knife
- 1/2" Socket

HARDWARE USED

5x

-  #90-200 Hex Bolt 5/16" x 1/2"
-  #98-116 Flat Washer
-  #94-116 Serrated Nut

1.2.2 Attach both wings to the upper and lower panels.

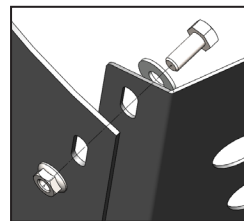
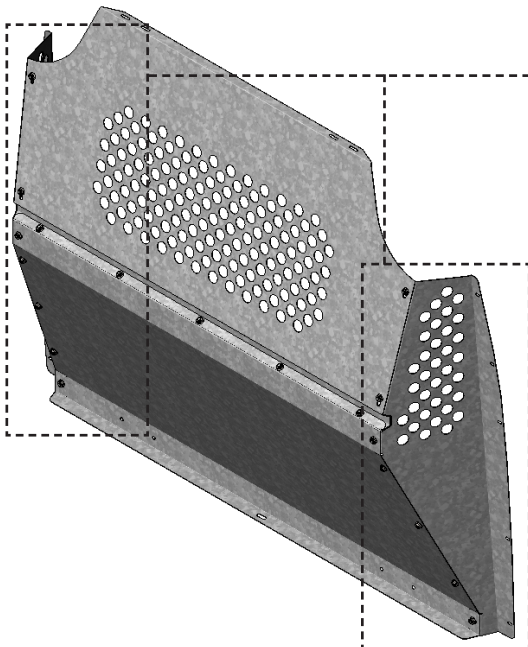



TOOLS

- Cordless Impact
- 1/2" Socket

HARDWARE USED

14x

-  #90-200 Hex Bolt 5/16" x 1/2"
-  #98-116 Flat Washer
-  #94-116 Serrated Nut

1.2.3 Attach the edge trims on these locations.

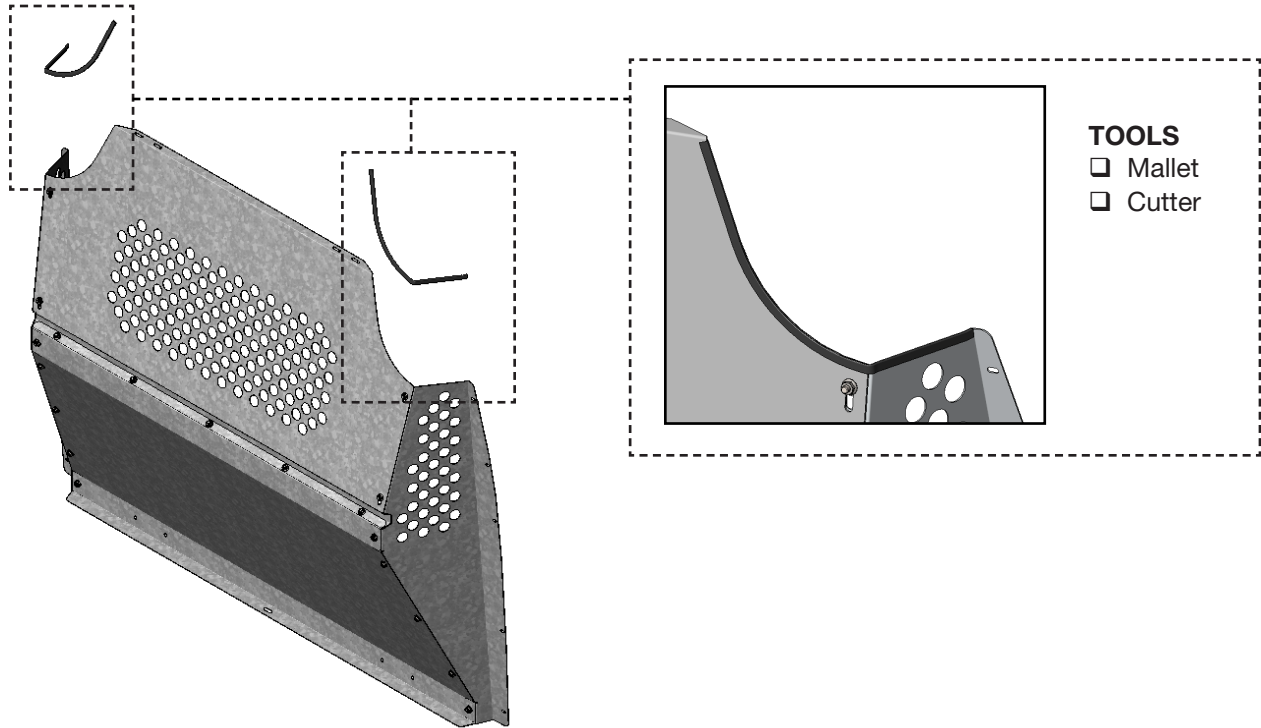

1.2.4 Attach the floor bracket to the lower panel.

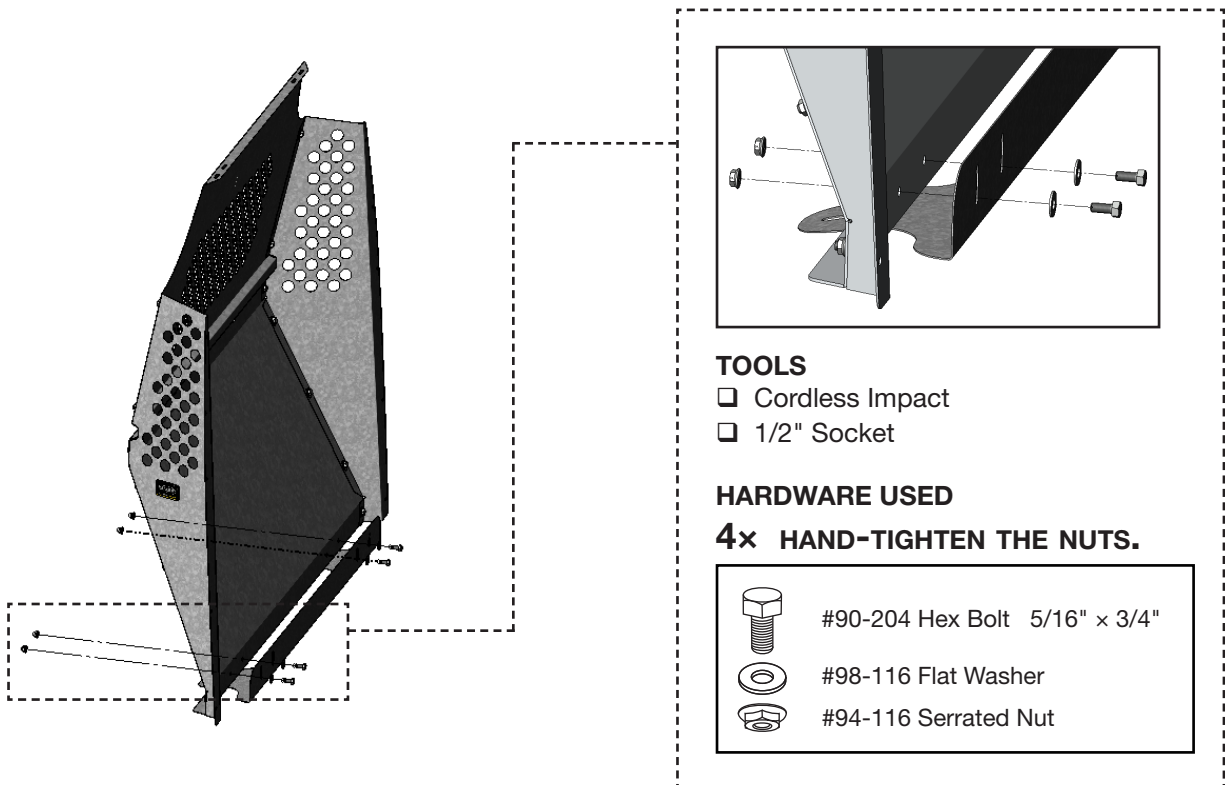

PHASE 2 – INSTALLATION

2.1 TIPS ON HOW TO ATTACH A PLUSNUT

2.1.1 Attach the plusnut using the plusnut gun.

TIPS: Put the plusnut on the plusnut gun, then attach the plusnut in the hole by turning the gun forward until the plusnut locks, then remove the gun by turning in reverse.

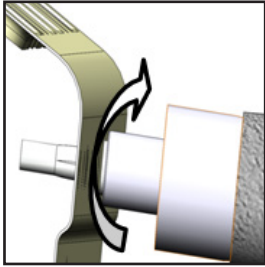

FORWARD

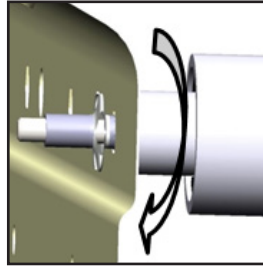

REVERSE

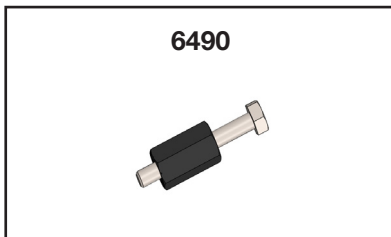

2.1.2 Attach the plusnut using the 6490 plusnut tool.

NOTE: The hardware used for the 6490 plusnut tool is not included in the fastener bag. The 6490 plusnut tool can be ordered separately upon demand at no charge.



6490

HARDWARE USED

-  Flat washer 1/4"
-  Flat washer 1/4" BS x 3/4" OD

TOOLS

- Cordless Impact
- 7/16" Socket
- 9/16" Wrench

TIPS STEP 1:

Assemble the 6490 plusnut tool with the hardware needed, plusnut and the 9/16" wrench as shown.



TIPS STEP 2:

Attach the plusnut in the hole by turning the bolt forward using an impact with a 7/16" socket until the plusnut locks, then remove the bolt by turning the impact in reverse.

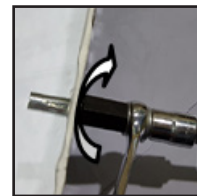

FORWARD



REVERSE

PHASE 2 – INSTALLATION

2.2 VEHICLE PREPARATION

2.2.1 Floor preparation.

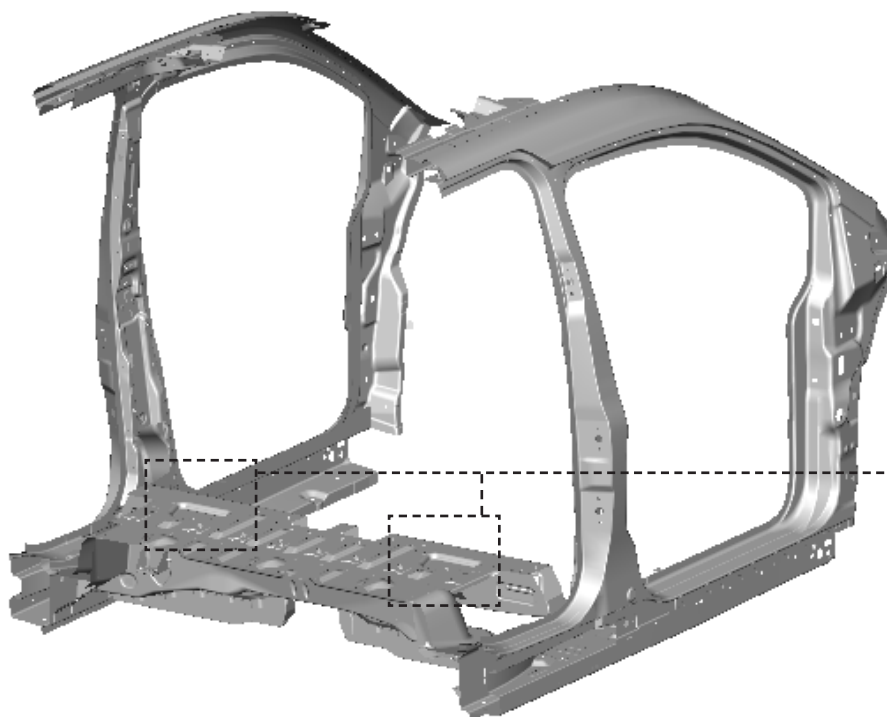

Remove the 2 D-rings,
for re-use.

TOOLS

- Cordless Impact
- T50 Torque Bit

2.2.2 Roof preparation.



Use 3/8" drill to enlarge these 4 factory holes.

TOOLS

- Drill Collar Set at 1/2"
- Cordless Drill
- 3/8" Drill Bit



Attach plusnuts on the 4 factory holes.

TOOLS

- Plusnut Tool

HARDWARE USED

4x

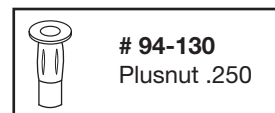

94-130
Plusnut .250

PHASE 2 – INSTALLATION

2.3 CONTOURED PARTITION INSTALLATION

2.3.1 Lift the partition inside the van, then attach the 2 ceiling brackets on the upper panel.

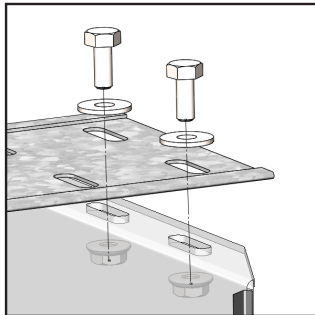
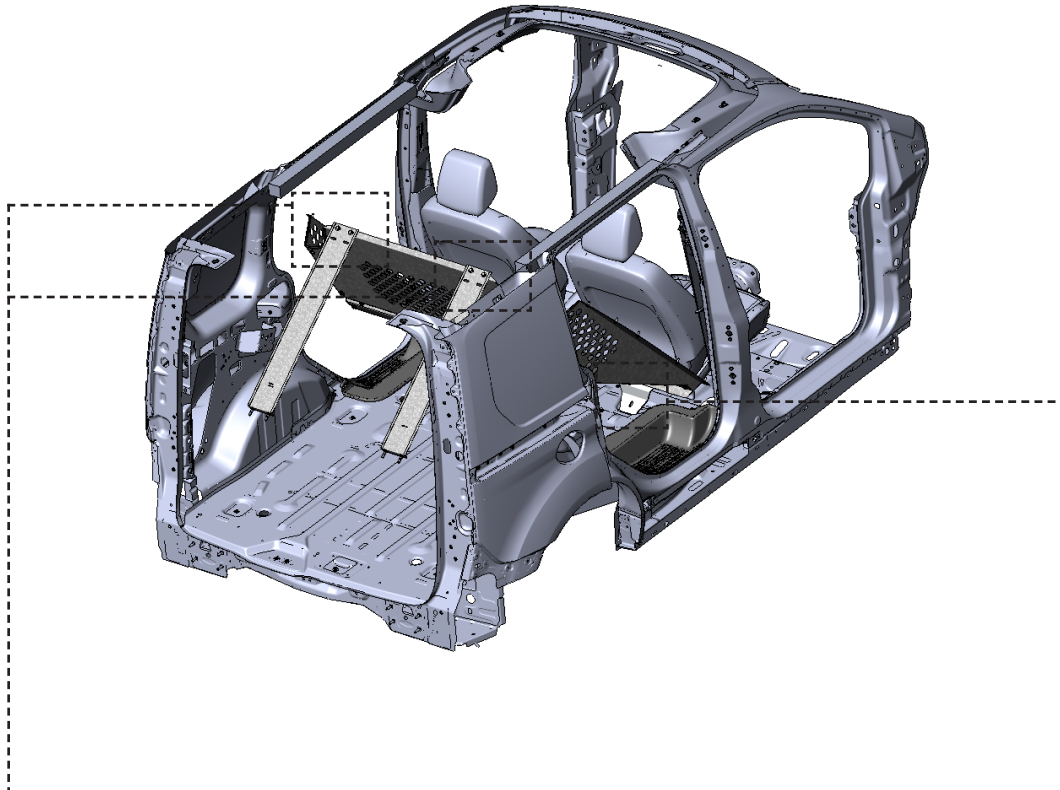

TOOLS

- Cordless Impact
- 7/16" Socket

HARDWARE USED

4x

-  #90-108 Hex Bolt 1/4" x 5/8"
-  #98-112 Flat Washer
-  #94-112 Serrated Nut

NOTE: Slide the floor bracket into the slots on the floor.

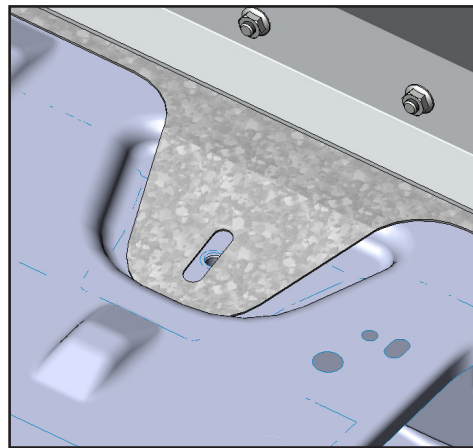

2.3.2 Attach the 2 ceiling brackets using the hex bolts into the plusnuts.

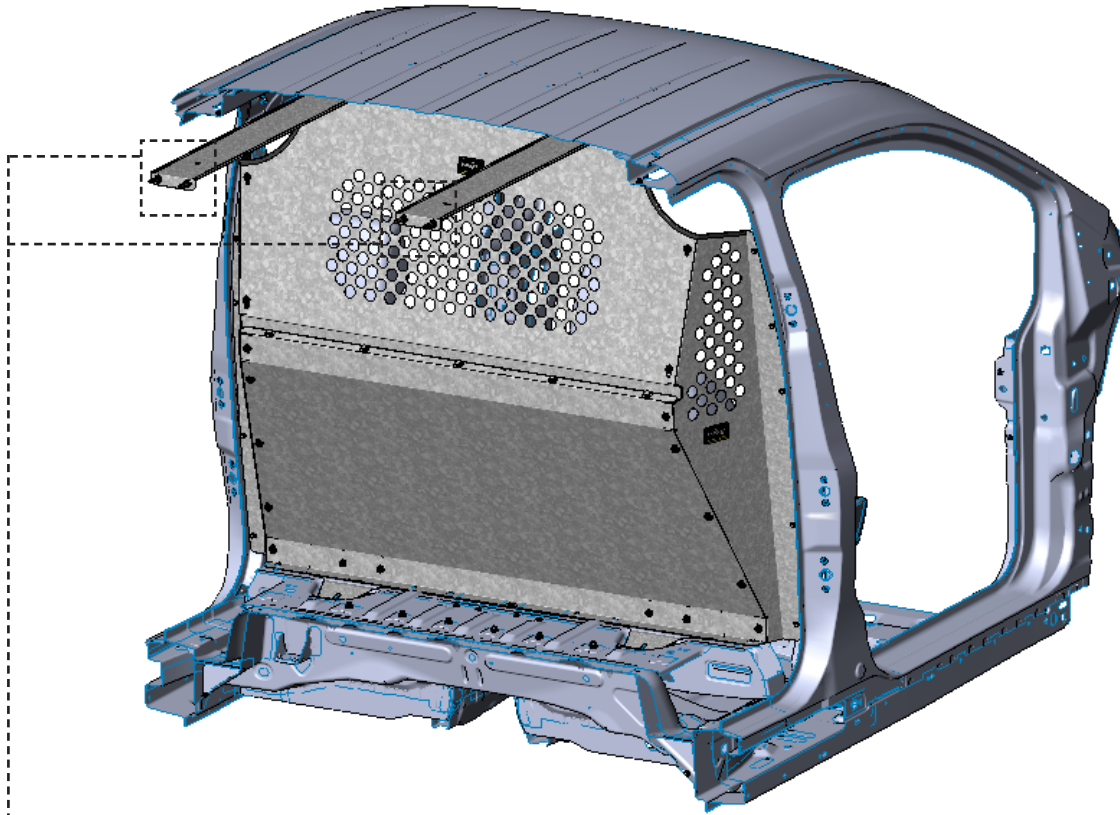

TOOLS

- Socket Wrench
- 7/16" Socket

HARDWARE USED

4x



#90-118 Hex Bolt 1/4" x 1-1/4"



#98-118 Lock Washer



#98-112 Flat Washer

2.3.3 Screw both wings to the van.

NOTE: Be careful not to overtighten.

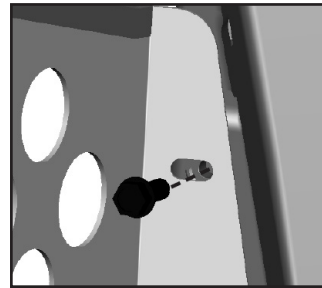
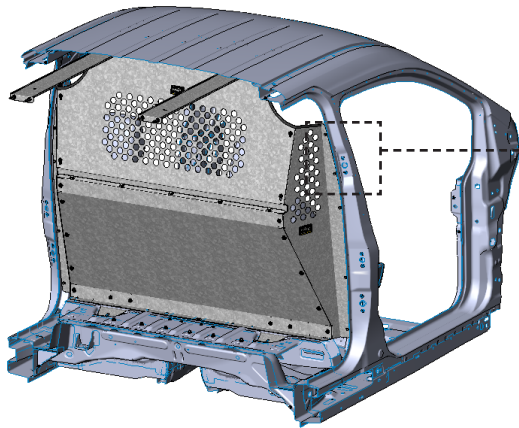

TOOLS

- Cordless Drill
- 10mm Socket
- 9/64" Drill Bit

NOTE: Drill the holes using 9/64" drill bit to remove the paint inside the holes.

HARDWARE USED

10x



#90-971 Self-Tapping Screw M6

2.3.4 Attach the floor bracket to the van using 2 D-rings, then tighten the bolts that attach the floor bracket and lower panel.

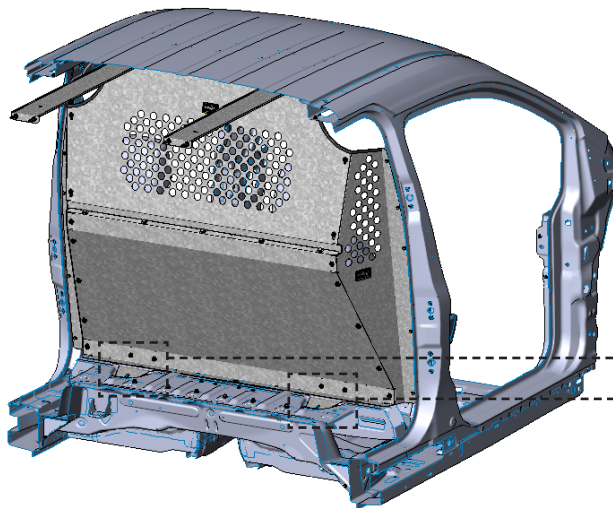

TOOLS

- Cordless Impact
- T50 Torque Bit

HARDWARE USED

2x

Use the D-ring bolt

2.3.5 Apply the warning label on the upper panel.

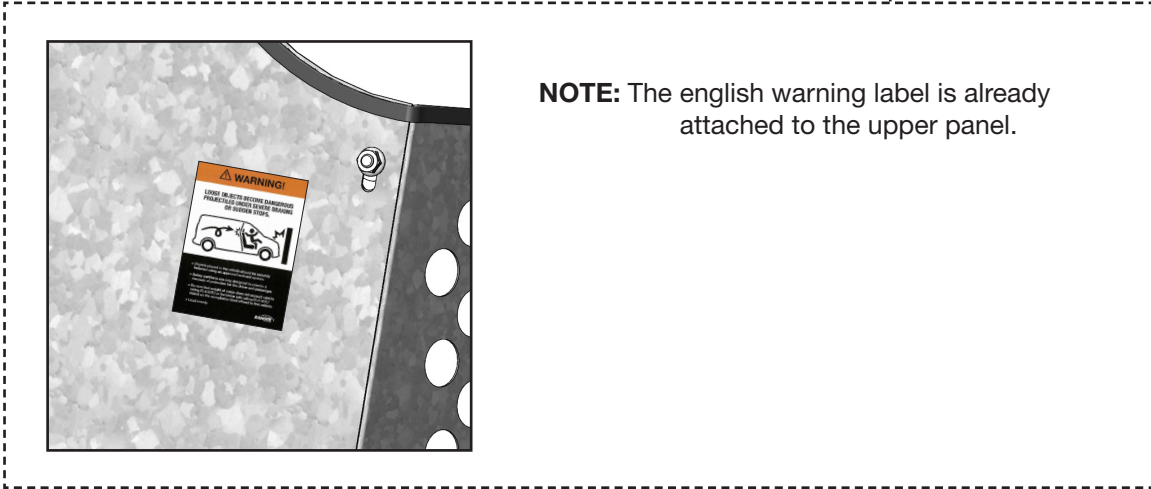
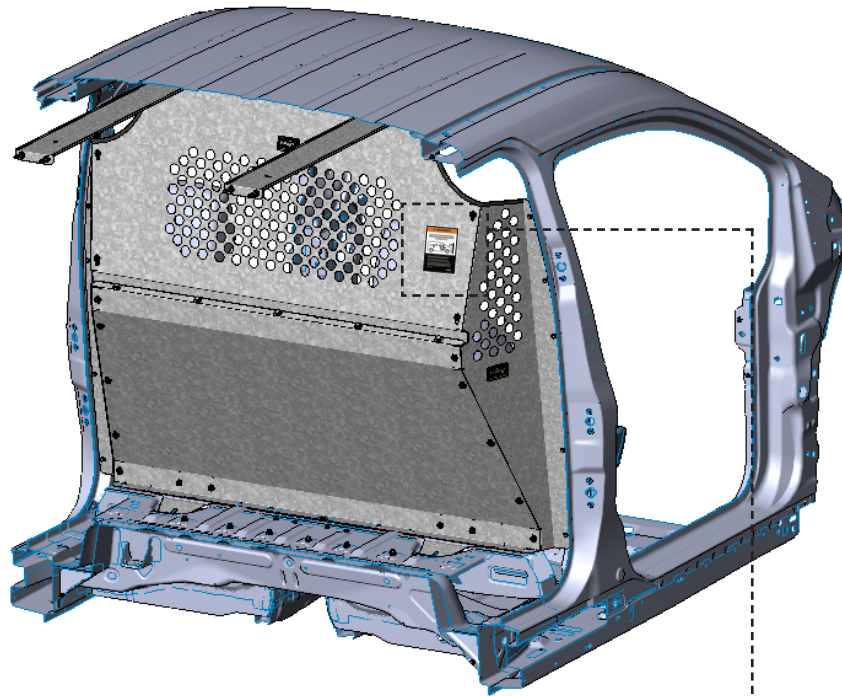

NOTE: The english warning label is already attached to the upper panel.

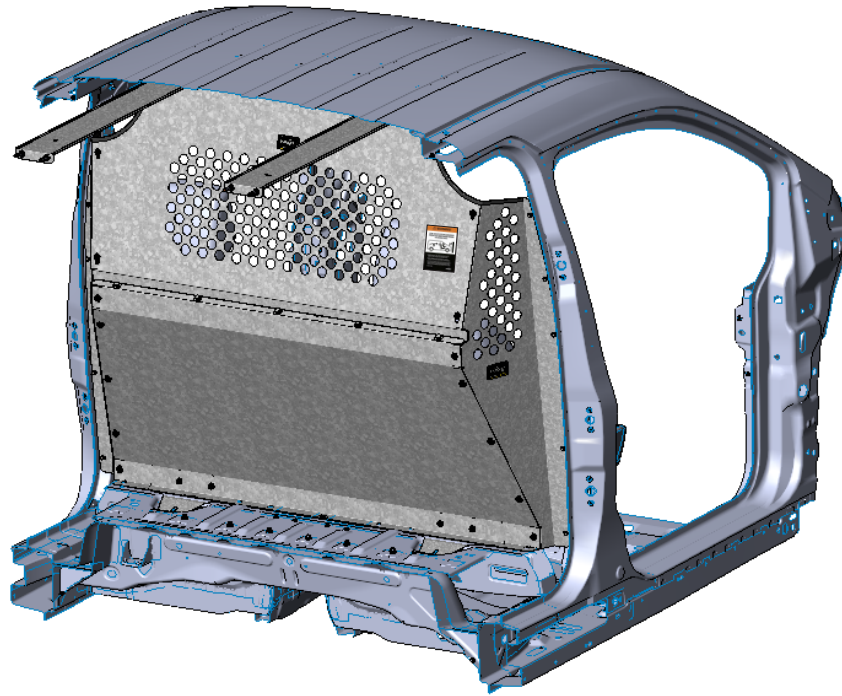

**“Congratulations, you have successfully installed your
C10-E Partition!”**

Thank you for doing business with us.”

For any feedback or suggestions you may have, please contact: cs@rangerdesign.com

