

INSTALLATION GUIDE

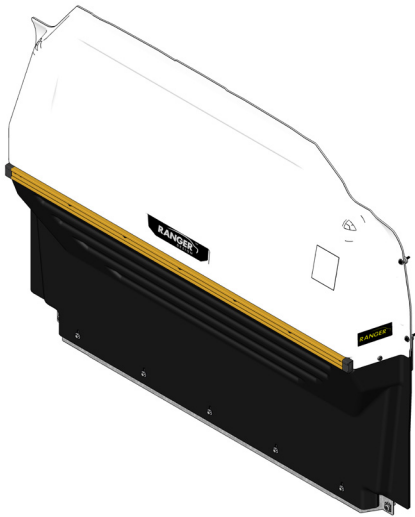

3320-FTL



3310-FTL

CONTOURED PARTITION

Transit Partition Low Roof



Scan the QR for the latest Install-Guide.





BEFORE YOU BEGIN

READ, UNDERSTAND, AND FOLLOW ALL WARNINGS AND INSTRUCTIONS BEFORE USING THIS PRODUCT. FAILURE TO FOLLOW THESE DIRECTIONS MAY RESULT IN PROPERTY DAMAGE, SERIOUS BODILY INJURY, AND/OR DEATH. RANGER DESIGN IS NOT RESPONSIBLE FOR ANY PROPERTY DAMAGE, PERSONAL INJURY, OR DEATH THAT OCCURRED WHILE USING ANY RANGER DESIGN PRODUCTS.



WARNING

- Failure to use Ranger Design-provided fasteners, brackets, and proper installation guidelines could increase risk of serious personal injury and/or death.
- If drilling is required to complete this installation: improper drilling can cause property damage to vehicles and could lead to electric shock, fire, or even death.
- If drilling is required to complete this installation: Ensure that drilling is only performed on areas of the vehicle allowed by the vehicle's Original Equipment Manufacturer's Body Builders Layout Book (or equivalent document).
- Prior to installation, inspect the vehicle to ensure that installation will not interfere with, or cause obstruction of, any critical components such as electrical wiring, fuel tanks, fuel-cells, locks, latches, etc.
- The installer or manufacturer is responsible for ensuring anchorages are installed onto suitable wall and floor structures; wall and floor strength must meet applicable performance requirements.
- Do not install systems into any weak or unsound materials such as plastics, woods, thin-walled metals, etc. without proper reinforcement.
- Do not install this product where it could interfere with the deployment of airbags. Failure to comply could result in death or serious injury.
- Do not install this product where it could ingress on the Transit Occupant Protection Zone. Failure to comply could result in death or serious injury.
- Incorrect installation could cause water leaks, electric shock or fire.
- Any cargo vehicle with any cargo or equipment should use a certified partition. See Ranger Design website for some partition options. (<https://rangerdesign.com/>)
- Mountings rails are recommended for any attachment to the vehicle walls.
- All items in the cargo area should be properly secured and partition doors closed while the vehicle is in motion.
- Check your vehicle's tare weight and remaining load capacity with all the equipment installed. Never exceed the maximum Gross Vehicle Weight Rating (GVWR), Gross Axle Weight Ratings (GAWRs), or other maximum loads permitted by the vehicle's Original Equipment Manufacturer (OEM) and required by law.
- The heaviest items must be placed towards the bottom of the vehicle, while the lightest ones can be arranged upwards. Vehicle cargo loading weight proportion should follow the following guidelines:



- The final alterer and/ or modifier should review the warning sheet with the customer before the vehicle is released to the customer or for general use. These instructions should remain with the vehicles a all times.
- Any modification or unintended use of this product voids any warranty and could create a hazardous condition.
- Ranger Design provides recommended assembly and installation instructions which should be followed to ensure correct operation. Failure to do so could result in invalidating the product's compliance, warranty and cause injury. Notwithstanding, the final stage vehicle alterer and/or modifier is responsible for the integration, installation, and compliance of the product in its final location to all applicable regulations and standards. Failure to maintain compliance of the vehicle to applicable regulations and standards could be punishable by law. Alterers and/or modifiers should consult with all local authorities prior to commissioning.



CAUTION

- Drilling is required to complete this installation. Before drilling, ensure that you will not hit any critical parts of the vehicle like the gas tank, wiring harness, or hose. Consult the vehicle OEM documentation as necessary. When drilling, use a drill collar to reduce the risk of damage to the vehicle.
- Any materials, padding, or glazing installed in the vehicle must comply with FMVSS/CMVSS 201/205/302, as applicable.
- In the event of a motor vehicle accident or collision where a Ranger system has been installed, especially ones where the vehicle structure is damaged and/or the air bags deploy and/or the vehicle has been towed, the system must be inspected to ensure continued soundness and safety before returning the vehicle to service. Damaged components should be replaced as necessary.
- All system components should be regularly inspected, cleaned, and maintained pursuant to Ranger guidelines.

QUICK START GUIDE

Phase 1 - Assembly

<input type="checkbox"/> 1.1 Setup.....	4
<input type="checkbox"/> 1.2 Partition Assembly.....	7

Phase 2 - Installation

<input type="checkbox"/> 2.1 Tips On How To Attach a Plusnut.....	10
<input type="checkbox"/> 2.2 Vehicle Preparation.....	11
<input type="checkbox"/> 2.3 Contoured Partition Installation.....	12

REQUIRED ITEMS

- Cordless Impact
- Cordless Drill
- Marker
- Plusnut Tool
- Tape Measure
- 3/8" Drill Bit
- 7/16" Socket
- 1/2" Socket
- 1" Hole Saw
- 10mm Socket
- 13mm Socket

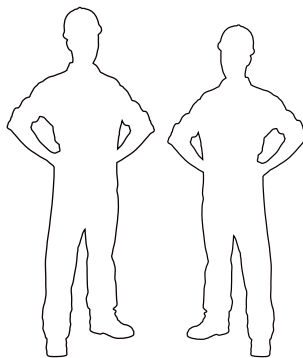

**2
PERSONS**

PHASE 1 – ASSEMBLY

1.1 SETUP

1.1.1 Unpack components; compare with the bill of materials.

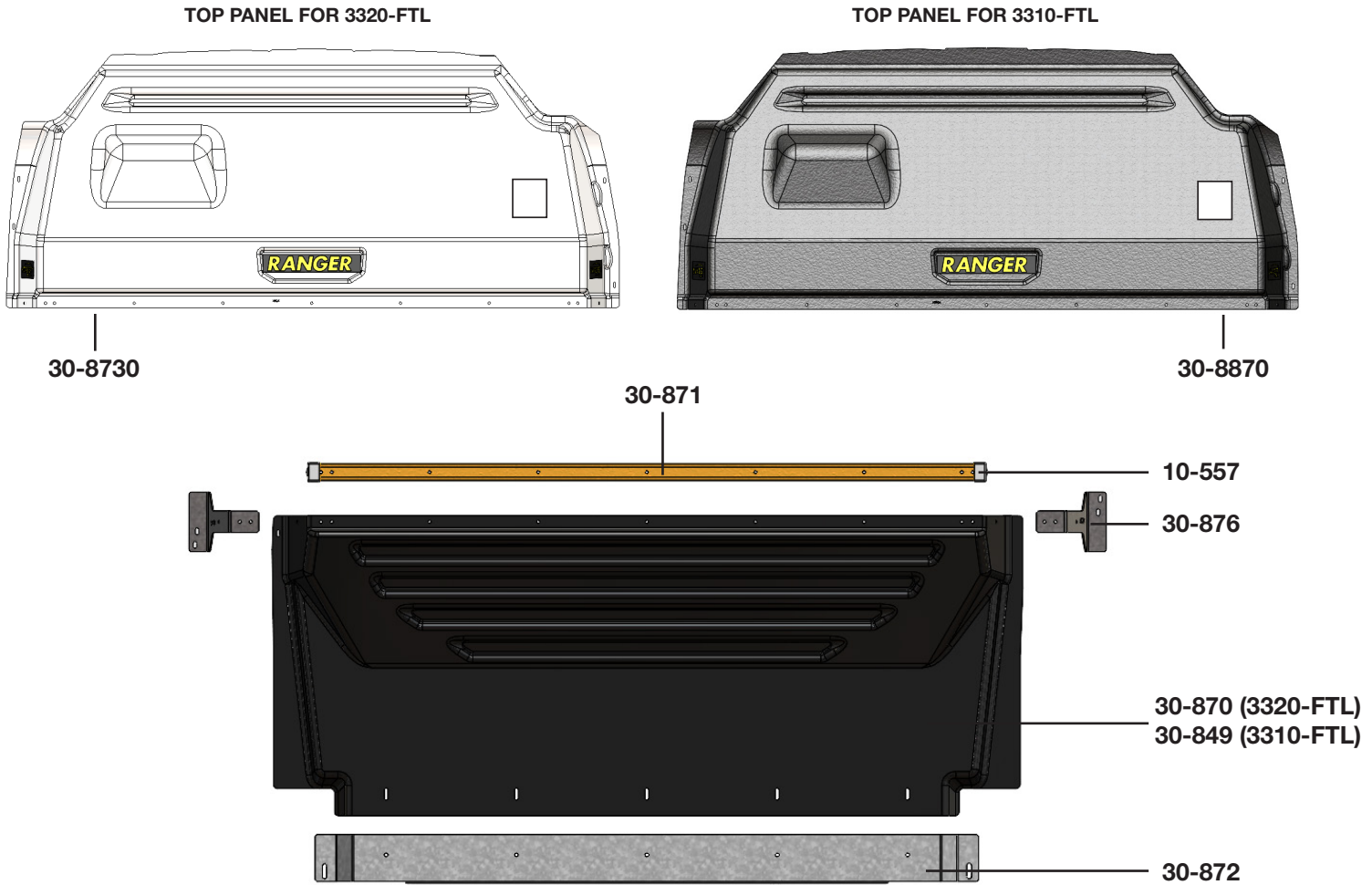

1.1.2 Verify all parts are present.

BILL OF MATERIALS

Item No.	Description	Qty.
10-557	Mounting Track End Cap	2
30-870 or 30-849	Lower Panel	1
30-871	Mounting Track	1
30-872	Floor Bracket	1
30-876	Side Bracket	2
79-932	Warning Label Bilingual	1
30-8730 or 30-8870	Upper Panel	1
94-3046	Assembly Fastener Bag	1
96-3031	Installation Fastener Bag	1

1.1.3 Identify the 94-3046 and 96-3031 fastener bags.

94-3046 Fastener Bag

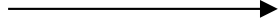

Hardware Assembly

11x  # 90-114 Hex Bolt
1/4"-20 x 1"
GR-5 ZINC

5x  # 90-204 Hex Bolt
5/16"-18 x 3/4"
GR-5 ZINC



11x  # 94-112 Serrated Nut
5/16"-20
ZINC

5x  # 94-116 Serrated Nut
5/16"-18
ZINC



5x  # 98-116 Flat Washer
5/16", 7/8" OD
ZINC

11x  # 98-112 Flat Washer
1/4", 3/4" OD
ZINC

11x

	#90-114 Hex Bolt 1/4" x 1"
	#98-112 Flat Washer
	#94-112 Serrated Nut







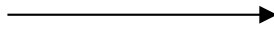

5x

	#90-204 Hex Bolt 5/16" x 3/4"
	#98-116 Flat Washer
	#94-116 Serrated Nut

96-3031 Fastener Bag



Hardware Assembly

3x		# 90-130	Hex Bolt 1/4"-20 x 2" GR-5 ZINC
2x		# 90-836	Hex Bolt M6-1.00 x 40 CL 12.9 DIN 933 BLACK OXIDE
2x		# 90-010	#90-010 Screw, Torx 7/16" x 1"
3x		# 94-130	Plusnut .250
5x		# 98-112	Flat Washer 1/4", 3/4" OD ZINC
5x		# 98-118	Lock Washer Regular 1/4" ZINC
10x		# 98-157	Spacer 0.375" ID, x 1.0" OD x 0.25" LONG NYLON
5x		# 98-158	Retaining Washer M16 (1/4") NYLON
2x		# 98-141	#98-141 Square Flat Washer

2x



#90-010 Screw, Torx 7/16" x 1"
#98-141 Square Flat Washer

3x



#90-130 Hex Bolt 1/4" x 2"
#98-118 Lock Washer
#98-112 Flat Washer
#98-157 Spacers (2)
#98-158 Retaining Washer
#94-130 Plusnut .250

2x



#90-836 Hex Bolt M6 x 40
#98-118 Lock Washer
#98-112 Flat Washer
#98-157 Spacers (2)
#98-158 Retaining Washer

1.2.1 Attach the end caps on the both ends of the mounting track.

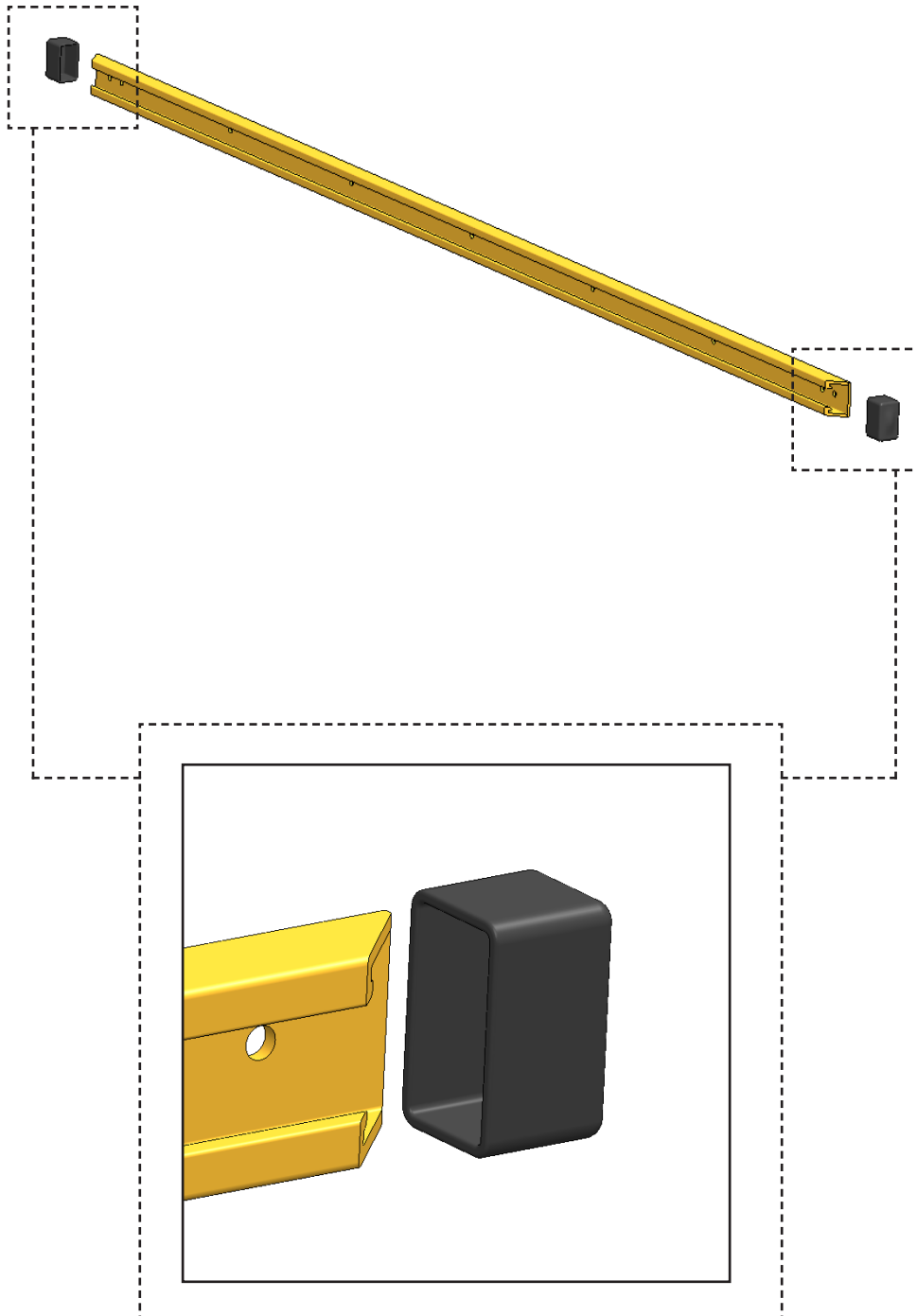

1.2.2 Attach the lower panel and mounting track to the upper panel.

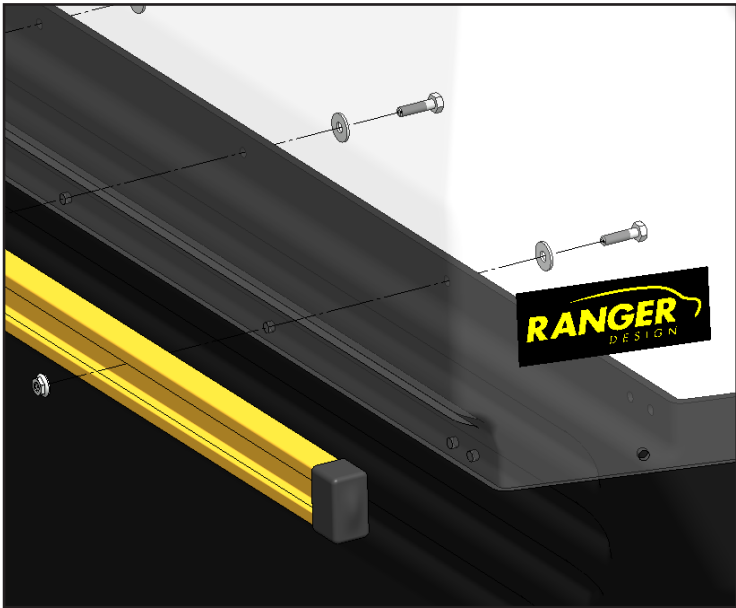
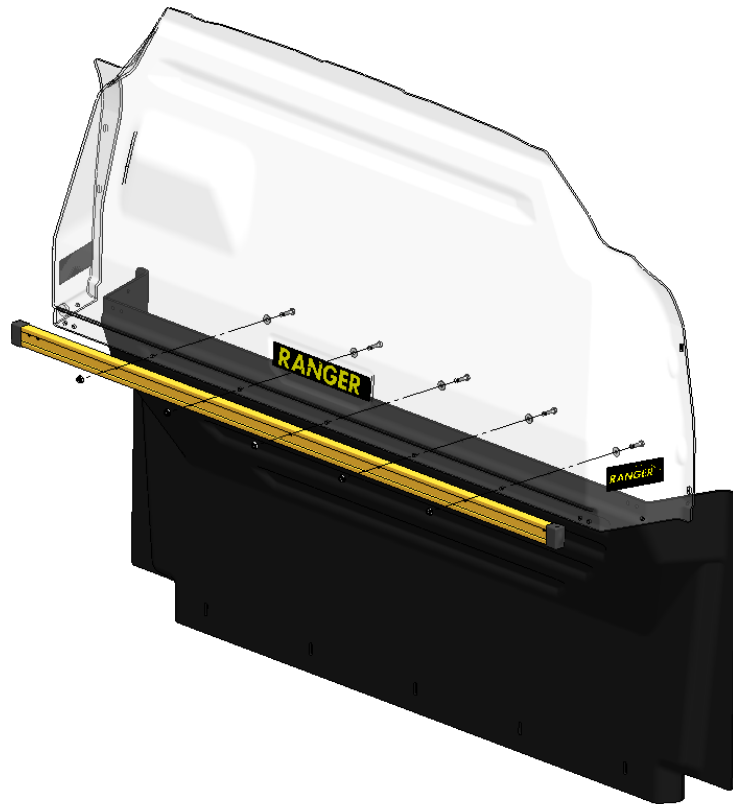



TOOLS

- Cordless Impact
- 7/16" Socket

HARDWARE USED

5x

	#90-114 Hex Bolt 1/4" x 1"
	#98-112 Flat Washer
	#94-112 Serrated Nut

1.2.3 Attach the side brackets to the panels and track.

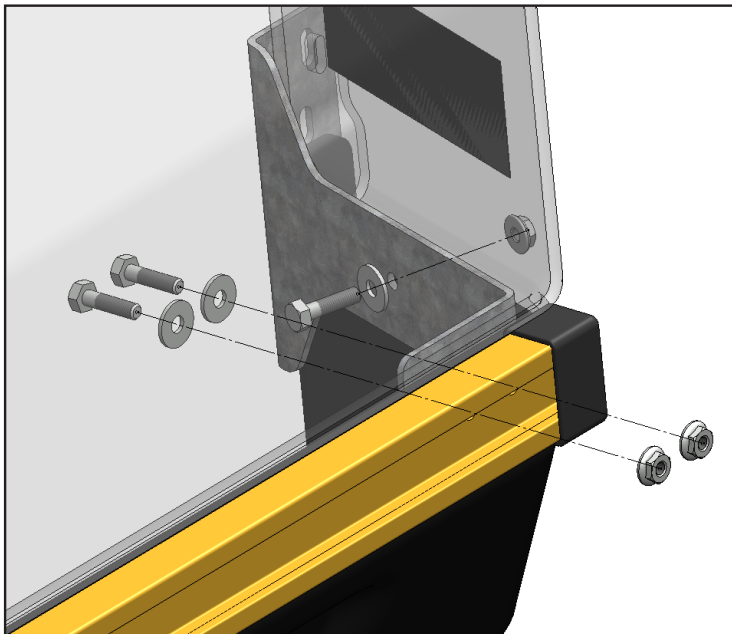
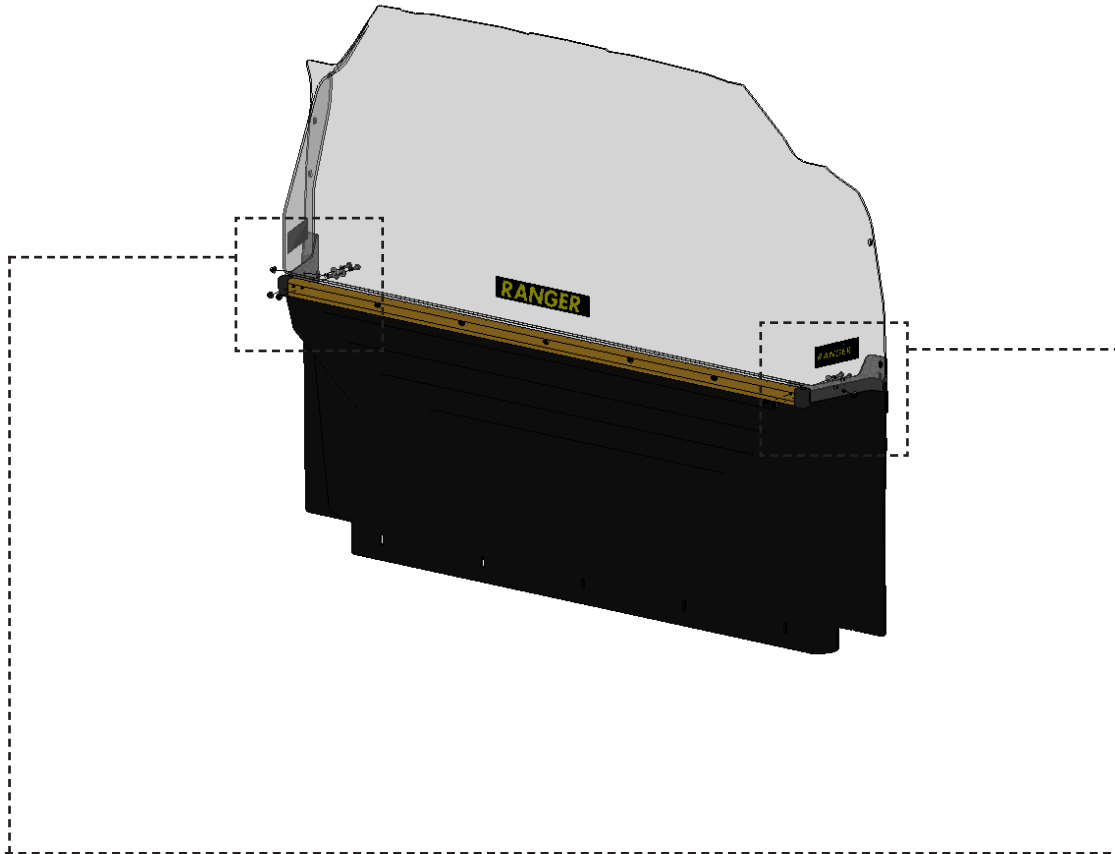



TOOLS

- Cordless Impact
- 7/16" Socket

HARDWARE USED

6x

- | | |
|--|----------------------------|
|  | #90-114 Hex Bolt 1/4" x 1" |
|  | #98-112 Flat Washer |
|  | #94-112 Serrated Nut |

PHASE 2 – INSTALLATION

2.1 TIPS ON HOW TO ATTACH A PLUSNUT

2.1.1 Attach the plusnut using the plusnut gun.

TIPS: Put the plusnut on the plusnut gun, then attach the plusnut in the hole by turning the gun forward until the plusnut locks, then remove the gun by turning in reverse.

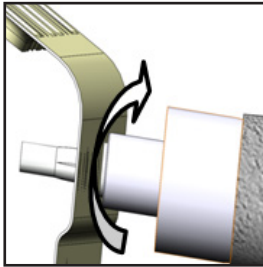

FORWARD

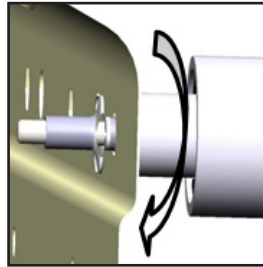

REVERSE

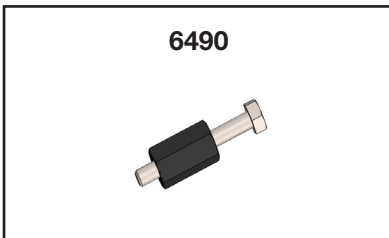

2.1.2 Attach the plusnut using the 6490 plusnut tool.

NOTE: The hardware used for the 6490 plusnut tool is not included in the fastener bag.
The 6490 plusnut tool can be ordered separately upon demand at no charge.



6490

HARDWARE USED

-  Flat washer 1/4"
-  Flat washer 1/4" BS x 3/4" OD

TOOLS

- Cordless Impact
- 7/16" Socket
- 9/16" Wrench

TIPS STEP 1:

Assemble the 6490 plusnut tool with the hardware needed, plusnut and the 9/16" wrench as shown.



TIPS STEP 2:

Attach the plusnut in the hole by turning the bolt forward using an impact with a 7/16" socket until the plusnut locks, then remove the bolt by turning the impact in reverse.

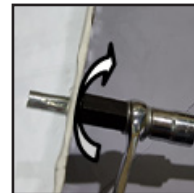

FORWARD



REVERSE

2.2.1 Driver and passenger sides preparation.

NOTE: This partition is design w/ floor make a new holes in the van if the holes is not align in the holes of the panels.

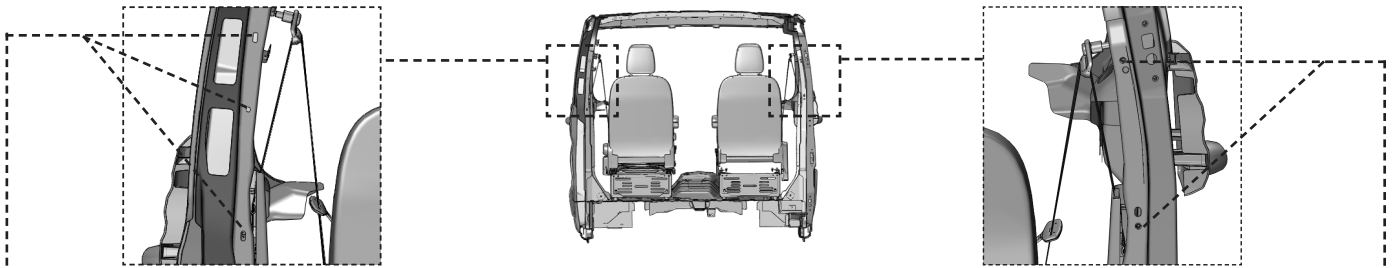

Put a mark on the plastic over these 2 holes.



- TOOLS**
- Marker

Use 1" hole saw to drill through the plastic cover over these two factory holes.



- TOOLS**
- 1" Hole Saw
 - Cordless Drill

Use 3/8" drill to enlarge the bottom part of these two factory holes.



- TOOLS**
- Drill Collar Set at 1/2"
 - Cordless Drill
 - 3/8" Drill Bit

Attach plusnuts on the two factory holes.



- TOOLS**
- Plusnut Tool
- HARDWARE USED**
- 3x**

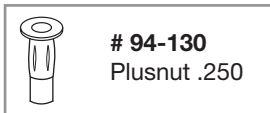

Remove the factory handle in the van.

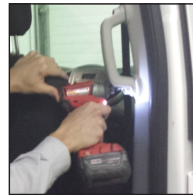

- TOOLS**
- Flat Screwdriver
 - Cordless Impact
 - 10mm Socket

After removing the handle, pull the rubber out, then remove the bracket by removing the two bolts.

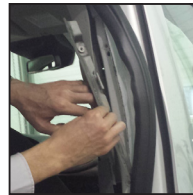

- TOOLS**
- Cordless Impact
 - 10mm Socket

Put a mark on the plastic over the 2 threaded holes.

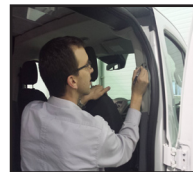

- TOOLS**
- Marker

Gently pull the plastic b-pillar from the metal. Use a 1" hole saw to drill through the plastic cover over these two factory threaded holes. (Use caution not to damage the threaded holes).



- TOOLS**
- 1" Hole Saw
 - Cordless Drill

2.3.1 Attach the upper panel to the passenger side of the van.



Put a bolt, lock washer, flat washer, 2 spacers and a retaining washer in the 1st and 2nd holes of the passenger side of the upper panel.

HARDWARE USED

2x



#90-836 Hex Bolt M6 x 40

#98-118 Lock Washer

#98-112 Flat Washer

#98-157 Spacers (2)

#98-158 Retaining washer

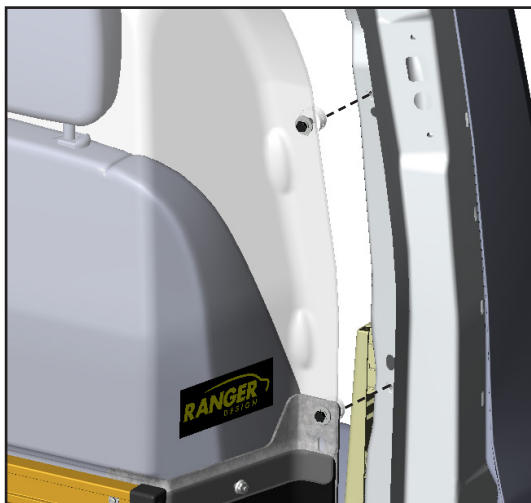

Attach the upper panel to the passenger side threaded holes of the vehicle.

NOTE: Hand-tighten the bolts just to hold the upper panel for adjustment.

TOOLS

- Cordless Impact
- 10mm Socket



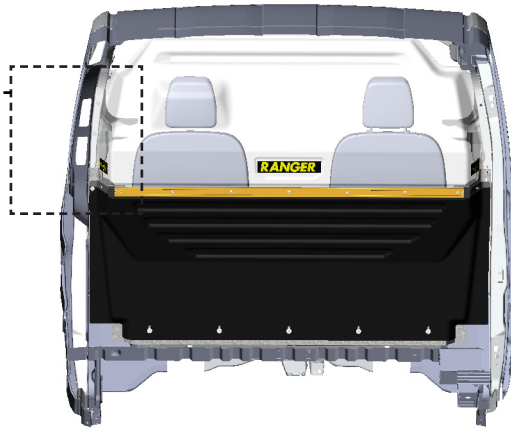

2.3.2 Attach the upper panel to the driver side of the van.



Put a bolt, lock washer, flat washer, 2 spacers and a retaining washer in the 3 holes of the driver side of the upper panel.

HARDWARE USED

3x

-  #90-130 Hex Bolt 1/4" x 2"
-  #98-118 Lock Washer
-  #98-112 Flat Washer
-  #98-157 Spacers (2)
-  #98-158 Retaining Washer

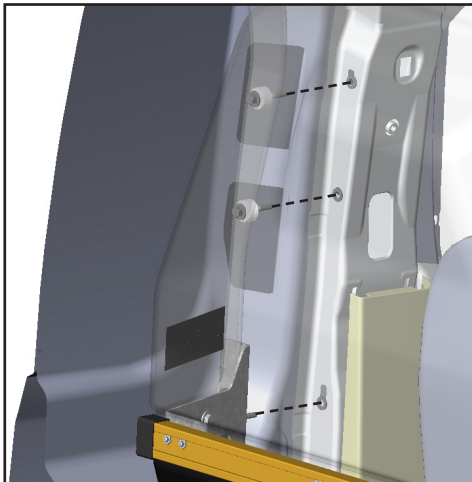

Attach the upper panel to the plusnuts on the driver side of the vehicle.

TOOLS

- Socket Wrench
- 7/16" Socket

2.3.3 Attach the lower panel to the floor bracket.

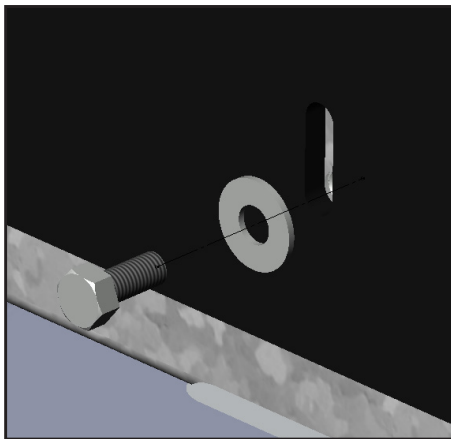

TOOLS

- Cordless Impact
- 1/2" Socket

HARDWARE USED

5x



#90-204 Hex Bolt 5/16" x 3/4"



#98-116 Flat Washer



#94-116 Serrated Nut

2.3.4 Re-attach D-Rings or use hardware to bolt to B-Pillar.

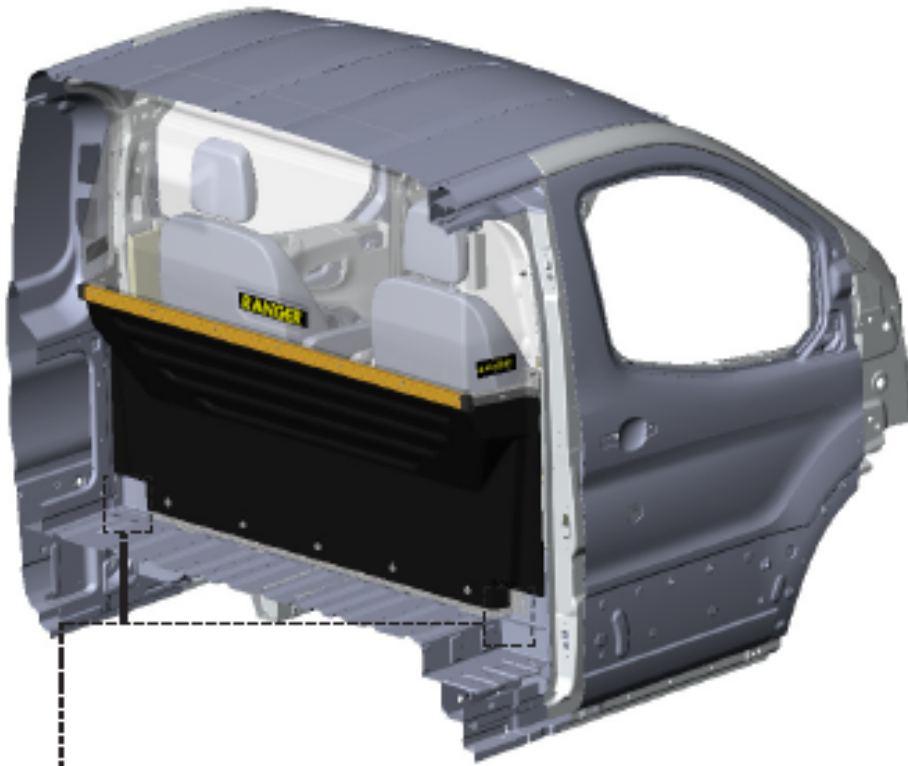

Attach the floor bracket to the floor re-using the 2 D-ring bolts with the addition of the square washers, in between the D-rings and floor bracket.

Note: Use 90-010 if D-rings are not available.

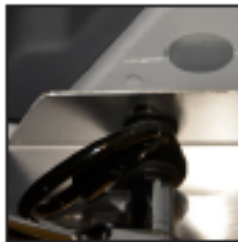

TOOLS

- Socket Wrench
- 13mm Socket
- T50 Torx Bit

HARDWARE USED

2x



2x



#90-010 Screw, Torx 7/16" x 1"

#98-141 Square Flat Washer

2.3.85 Apply the warning label on the passenger side wing.

NOTE: The english warning label is already attached to the upper panel.

WARNING: After installation is complete make sure all the bolts are tighten.

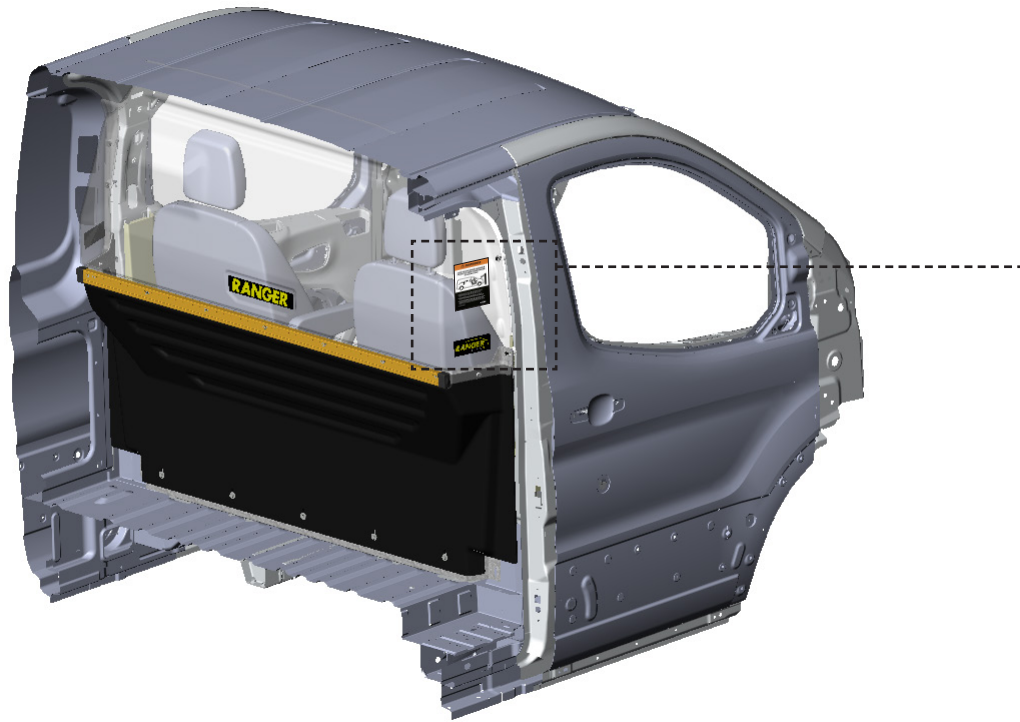

WARNING LABEL

“You have successfully installed your partition, thank you for doing business with us.”

For any feedback or suggestions, you may have, please contact: cs@rangerdesign.com