

INSTALLATION GUIDE

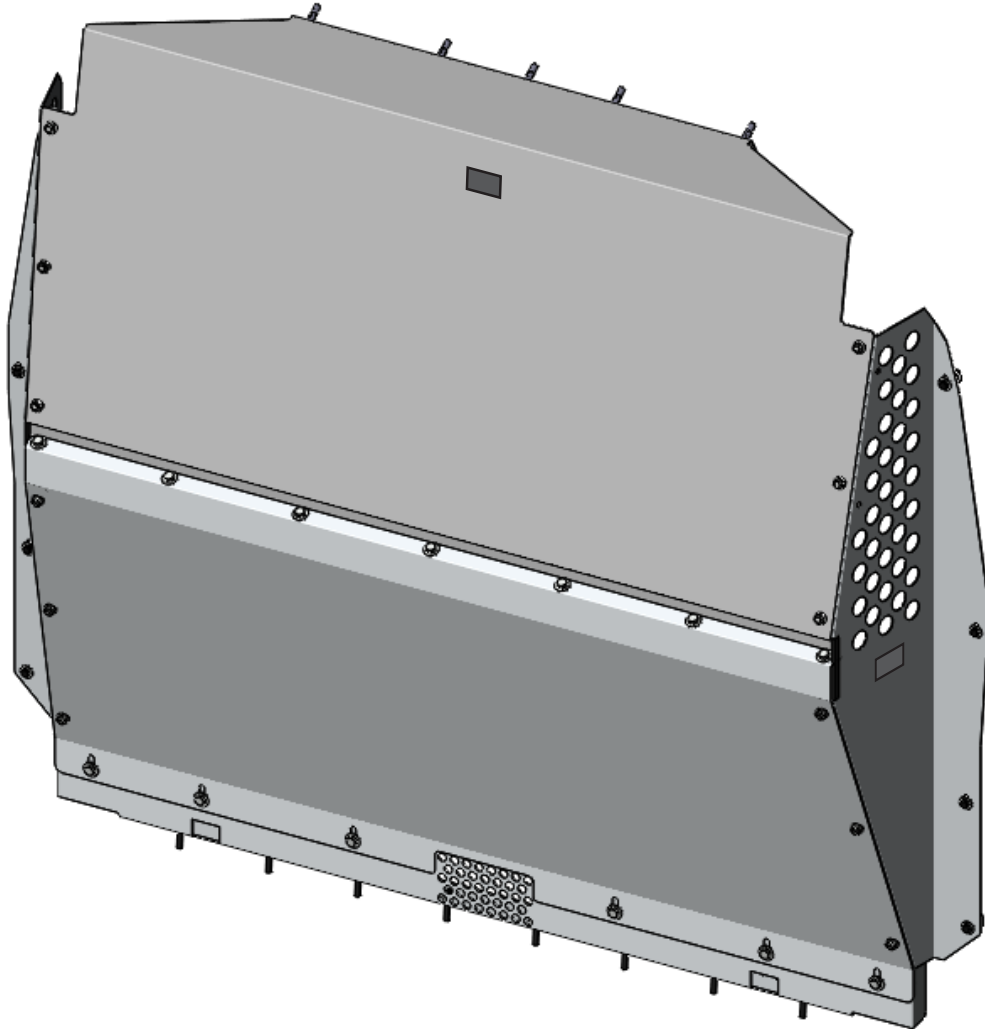

3010-PC CONTOURED PARTITION

Promaster City (Aluminum)



Scan the QR for the latest Install-Guide.





BEFORE YOU BEGIN

READ, UNDERSTAND, AND FOLLOW ALL WARNINGS AND INSTRUCTIONS BEFORE USING THIS PRODUCT. FAILURE TO FOLLOW THESE DIRECTIONS MAY RESULT IN PROPERTY DAMAGE, SERIOUS BODILY INJURY, AND/OR DEATH. RANGER DESIGN IS NOT RESPONSIBLE FOR ANY PROPERTY DAMAGE, PERSONAL INJURY, OR DEATH THAT OCCURRED WHILE USING ANY RANGER DESIGN PRODUCTS.



WARNING

- Failure to use Ranger Design-provided fasteners, brackets, and proper installation guidelines could increase risk of serious personal injury and/or death.
- If drilling is required to complete this installation: improper drilling can cause property damage to vehicles and could lead to electric shock, fire, or even death.
- If drilling is required to complete this installation: Ensure that drilling is only performed on areas of the vehicle allowed by the vehicle's Original Equipment Manufacturer's Body Builders Layout Book (or equivalent document).
- Prior to installation, inspect the vehicle to ensure that installation will not interfere with, or cause obstruction of, any critical components such as electrical wiring, fuel tanks, fuel-cells, locks, latches, etc.
- The installer or manufacturer is responsible for ensuring anchorages are installed onto suitable wall and floor structures; wall and floor strength must meet applicable performance requirements.
- Do not install systems into any weak or unsound materials such as plastics, woods, thin-walled metals, etc. without proper reinforcement.
- Do not install this product where it could interfere with the deployment of airbags. Failure to comply could result in death or serious injury.
- Do not install this product where it could ingress on the Transit Occupant Protection Zone. Failure to comply could result in death or serious injury.
- Incorrect installation could cause water leaks, electric shock or fire.
- Any cargo vehicle with any cargo or equipment should use a certified partition. See Ranger Design website for some partition options. (<https://rangerdesign.com/>)
- Mountings rails are recommended for any attachment to the vehicle walls.
- All items in the cargo area should be properly secured and partition doors closed while the vehicle is in motion.
- Check your vehicle's tare weight and remaining load capacity with all the equipment installed. Never exceed the maximum Gross Vehicle Weight Rating (GVWR), Gross Axle Weight Ratings (GAWRs), or other maximum loads permitted by the vehicle's Original Equipment Manufacturer (OEM) and required by law.
- The heaviest items must be placed towards the bottom of the vehicle, while the lightest ones can be arranged upwards. Vehicle cargo loading weight proportion should follow the following guidelines:



- The final alterer and/ or modifier should review the warning sheet with the customer before the vehicle is released to the customer or for general use. These instructions should remain with the vehicles a all times.
- Any modification or unintended use of this product voids any warranty and could create a hazardous condition.
- Ranger Design provides recommended assembly and installation instructions which should be followed to ensure correct operation. Failure to do so could result in invalidating the product's compliance, warranty and cause injury. Notwithstanding, the final stage vehicle alterer and/or modifier is responsible for the integration, installation, and compliance of the product in its final location to all applicable regulations and standards. Failure to maintain compliance of the vehicle to applicable regulations and standards could be punishable by law. Alterers and/or modifiers should consult with all local authorities prior to commissioning.



CAUTION

- Drilling is required to complete this installation. Before drilling, ensure that you will not hit any critical parts of the vehicle like the gas tank, wiring harness, or hose. Consult the vehicle OEM documentation as necessary. When drilling, use a drill collar to reduce the risk of damage to the vehicle.
- Any materials, padding, or glazing installed in the vehicle must comply with FMVSS/CMVSS 201/205/302, as applicable.
- In the event of a motor vehicle accident or collision where a Ranger system has been installed, especially ones where the vehicle structure is damaged and/or the air bags deploy and/or the vehicle has been towed, the system must be inspected to ensure continued soundness and safety before returning the vehicle to service. Damaged components should be replaced as necessary.
- All system components should be regularly inspected, cleaned, and maintained pursuant to Ranger guidelines.

QUICK START GUIDE

Phase 1 - Assembly

<input type="checkbox"/> 1.1 Setup.....	4
<input type="checkbox"/> 1.2 Partition Assembly.....	7

Phase 2 - Installation

<input type="checkbox"/> 2.1 Tips on how to attach a plusnut.....	9
<input type="checkbox"/> 2.2 Vehicle preparation.....	10
<input type="checkbox"/> 2.3 Contoured partition installation.....	14

REQUIRED ITEMS

- Cordless Impact
- Cordless Drill
- Knife or Cutter
- Mallet
- Philips Screw Driver
- Plusnut Tool
- Ratchet
- 1/2" Socket
- 7/16" Socket
- 10mm Socket
- 13mm Socket
- T30 Torque Bit
- T40 Torque Bit
- 9/16" Wrench
- 1" Holesaw

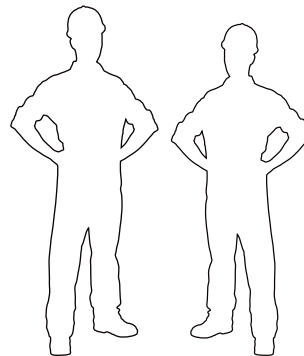

2
PERSONS

PHASE 1 – ASSEMBLY

1.1 SETUP

1.1.1 Unpack components; compare with the bill of materials.

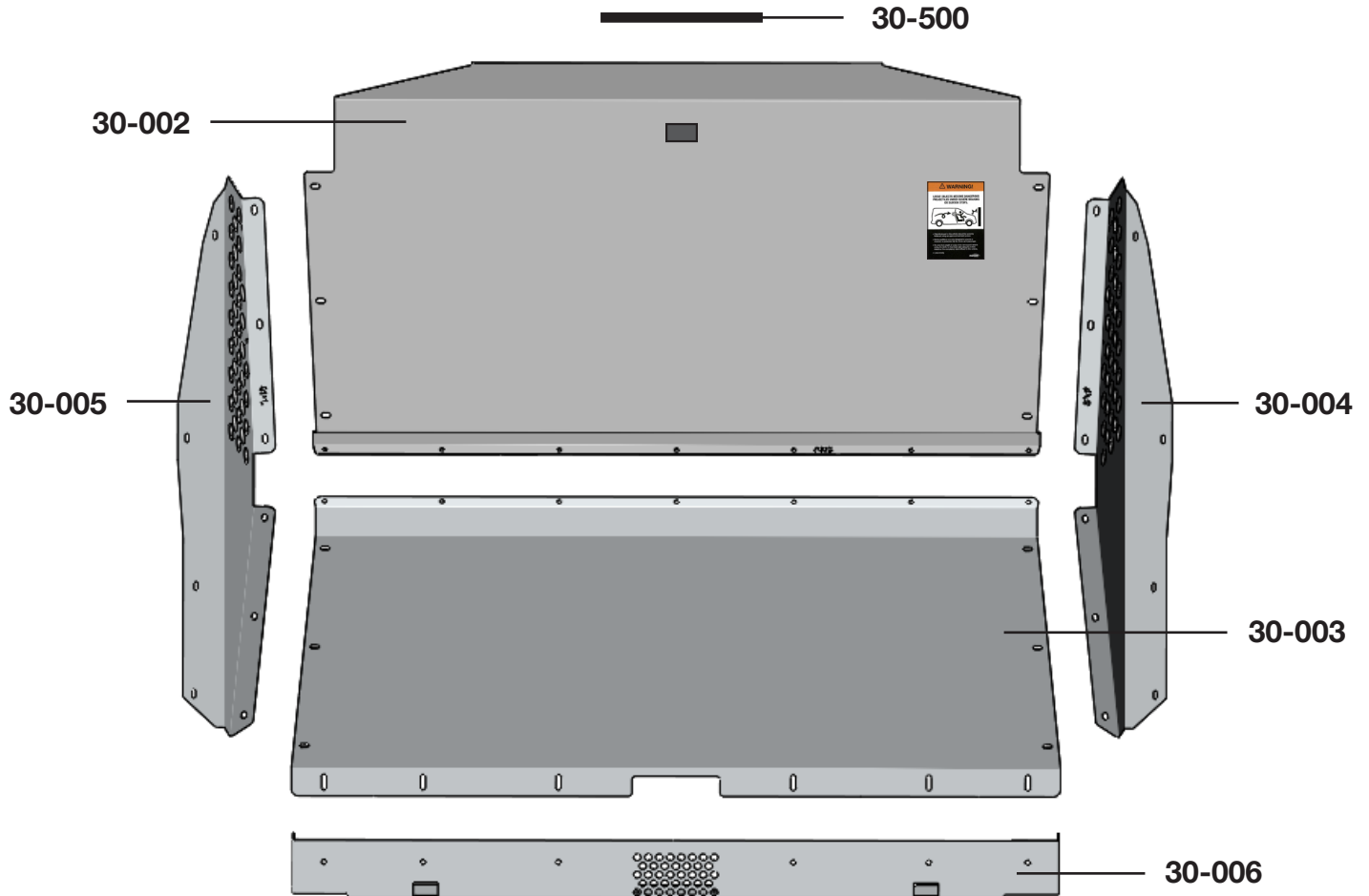





1.1.2 Verify all parts are present.



Item No.	Description	Qty.
30-002	Upper Panel	1
30-003	Lower Panel	1
30-004	Passenger Side Wing	1
30-005	Driver Side Wing	1
30-006	Floor Bracket	1
30-500	Edge Trim (QTY in Inches)	8
79-932	Bilingual Warning Label	1
94-3020	Assembly Fastener Bag	1
96-3012	Installation Fastener Bag	1



1.1.3 Identify the **Assembly** and **Installation** fastener bags.

Assembly Fastener Bag →

Hardware Assembly

- 13x  # 90-204 Hex Bolt
5/16"-18 x 3/4"
GR-5 ZINC
- 12x  # 90-484 Carriage Bolt
5/16"-18 x 5/8"
ZINC
- 25x  # 94-116 Serrated Nut
5/16"-18
ZINC
- 13x  # 98-116 Flat Washer
5/16", 7/8" OD
ZINC





- 13x**
-  #90-204 Hex Bolt 5/16" x 3/4"
 -  #98-116 Flat Washer
 -  #94-116 Serrated Nut



- 12x**
-  #90-484 Carriage Bolt 5/16" x 5/8"
 -  #94-116 Serrated Nut





Installation Fastener Bag →

Hardware Assembly

- 5x  # 90-118 Hex Bolt
1/4"-20 x 1-1/4"
GR-5 ZINC
- 8x  # 90-668 Hex Bolt
M8-1.25 x 40 CL 8.8 DIN
933 BLACK OXIDE
- 8x  # 90-836 Hex Bolt
M6-1.0 x 40 CL 12.9 DIN
933 BLACK OXIDE
- 5x  # 94-130 Plusnut .250
- 13x  # 98-112 Flat Washer
1/4", 3/4" OD
ZINC
- 8x  # 98-116 Flat Washer
5/16", 7/8" OD
ZINC
- 13x  # 98-118 Lock Washer
Regular 1/4"
ZINC
- 8x  # 98-122 Lock Washer
Regular 5/16"
ZINC
- 24x  # 98-157 Spacer
0.375" ID, x 1.0" OD x 0.25" L
NYLON
- 8x  # 98-158 Retaining Washer
M16 (1/4")
NYLON

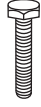
- 5x**
-  #90-118 Hex Bolt 1/4" x 1-1/4"
 -  #98-118 Lock Washer
 -  #98-112 Flat Washer
 -  #94-130 Plusnut .250

- 8x**
-  #90-668 Hex Bolt M8 x 40
 -  #98-122 Lock Washer
 -  #98-116 Flat Washer

- 8x**
-  #90-836 Hex Bolt M6 " x 40
 -  #98-118 Lock Washer
 -  #98-112 Flat Washer
 -  #98-157 Spacers (3)
 -  #98-158 Retaining Washer

PHASE 1 – FOR PROMASTER CITY 2021+

1.1.4 To clear the airbag brackets, cut both sides of the top edges, as

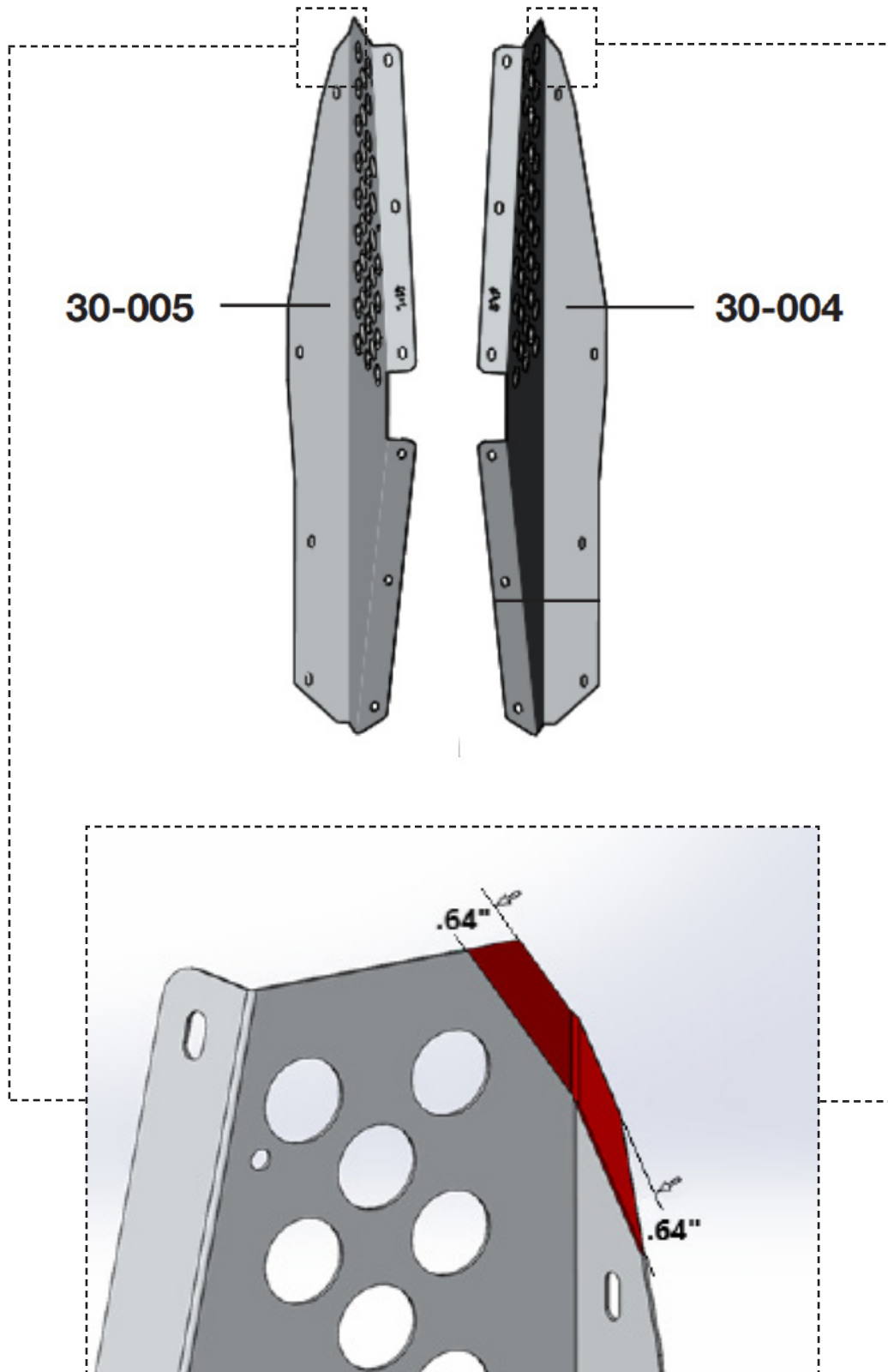

PHASE 1 – ASSEMBLY

1.2 PARTITION ASSEMBLY

1.2.1 Remove all the PVC from all the parts, then attach the upper panel to the lower panel.

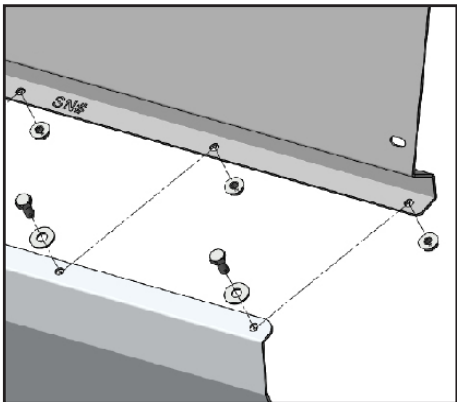
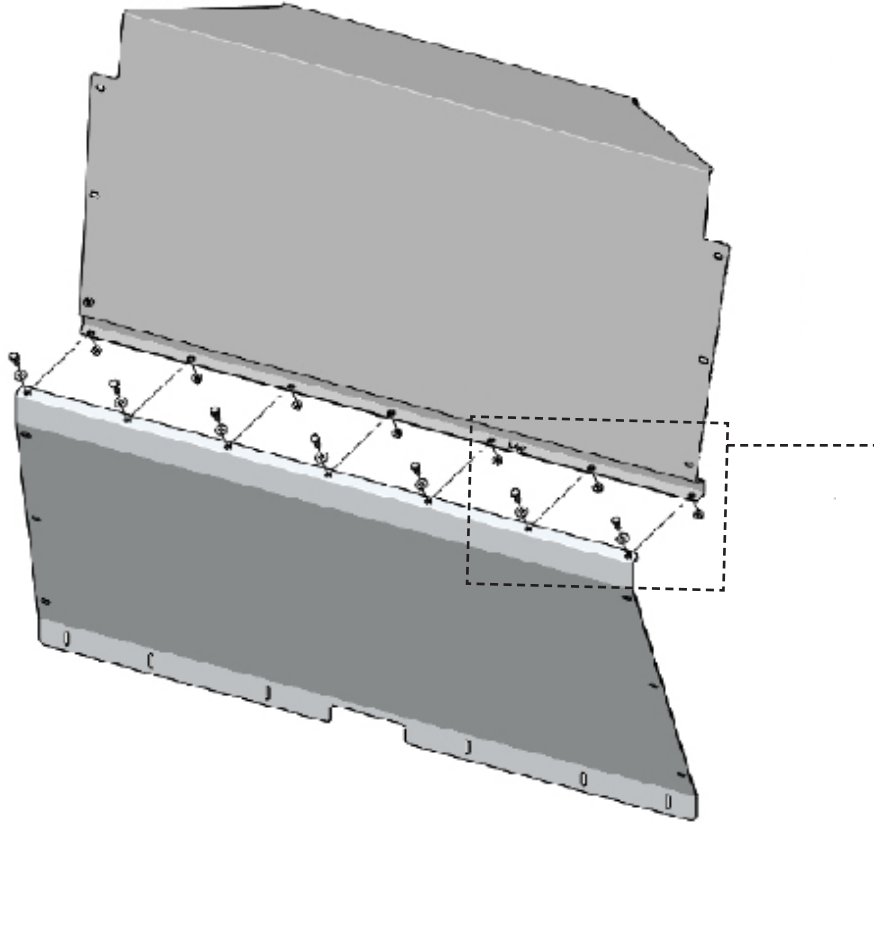



TOOLS

- Cordless Impact
- 1/2" Socket

HARDWARE USED

7x

	#90-204 Hex Bolt 5/16" x 3/4"
	#98-116 Flat Washer
	#94-116 Serrated Nut

1.2.2 Attach the edge trims on these locations.

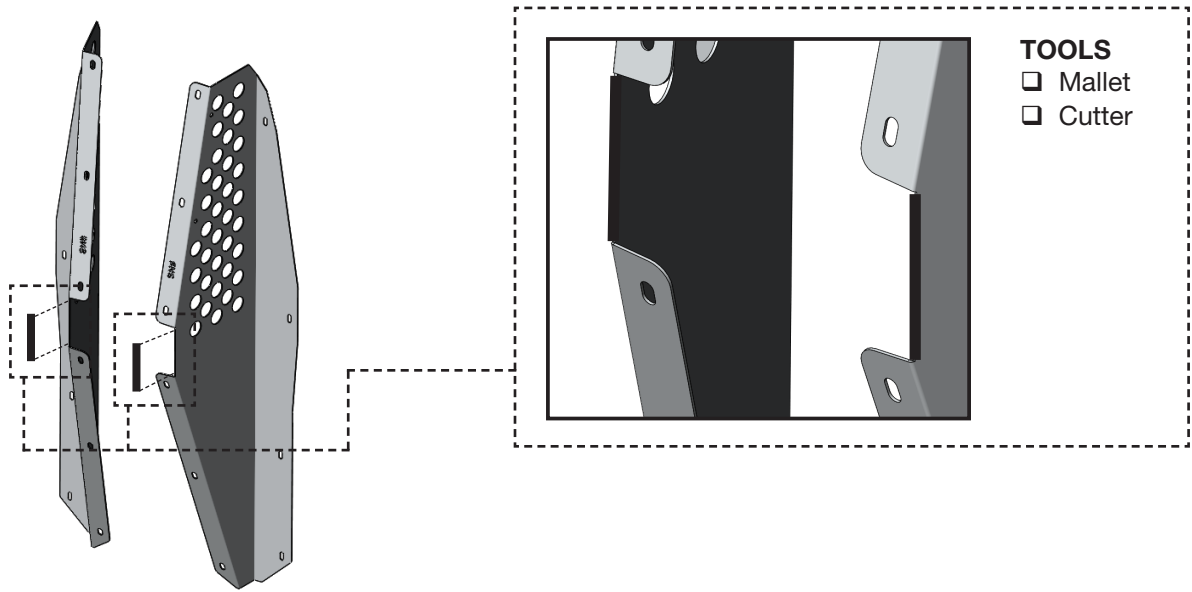

1.2.3 Attach both wings to the upper and lower panels.

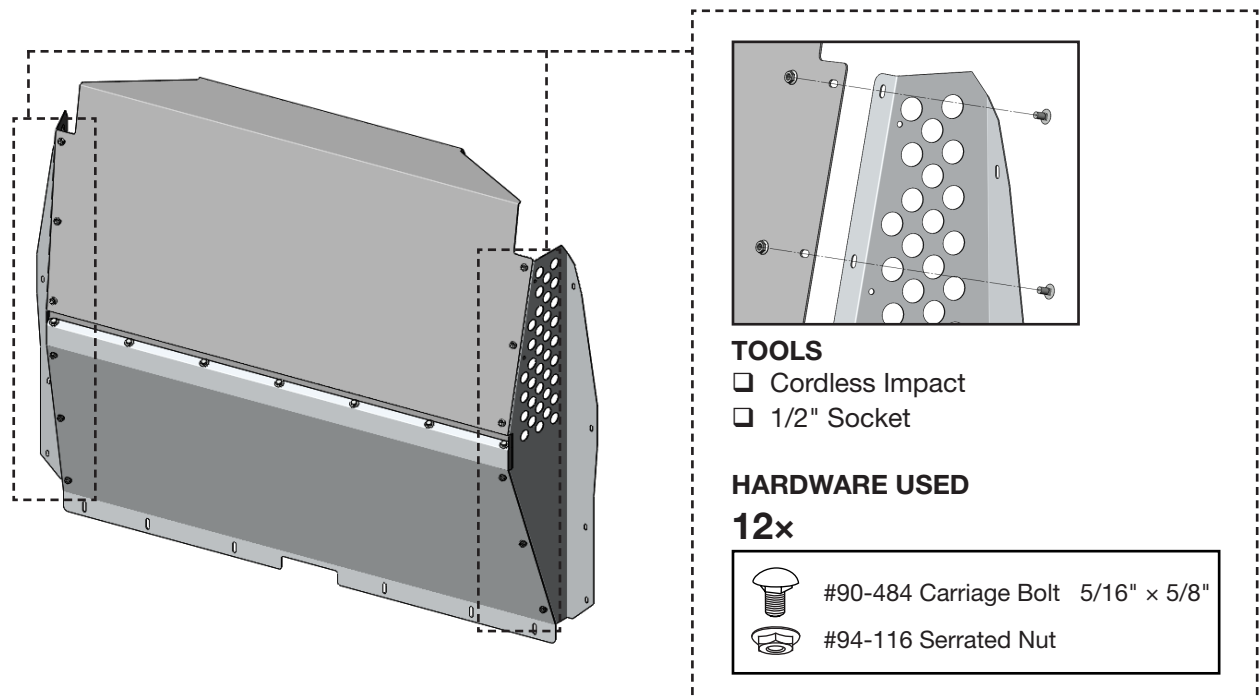

PHASE 2 – INSTALLATION

2.1 TIPS ON HOW TO ATTACH A PLUSNUT

2.1.1 Attach the plusnut using the plusnut gun.

TIPS: Put the plusnut on the plusnut gun, then attach the plusnut in the hole by turning the gun forward until the plusnut locks, then remove the gun by turning in reverse.

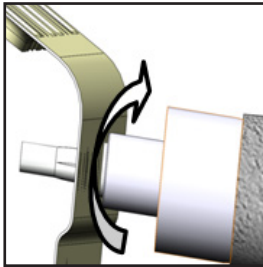

FORWARD

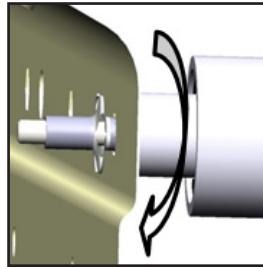

REVERSE

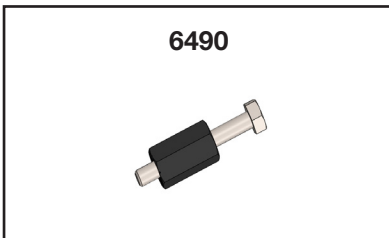

2.1.2 Attach the plusnut using the 6490 plusnut tool.

NOTE: The hardware used for the 6490 plusnut tool is not included in the fastener bag. The 6490 plusnut tool can be ordered separately upon demand at no charge.



6490

HARDWARE USED

-  Flat washer 1/4"
-  Flat washer 1/4" BS x 3/4" OD

TOOLS

- Cordless Impact
- 7/16" Socket
- 9/16" Wrench

TIPS STEP 1:

Assemble the 6490 plusnut tool with the hardware needed, plusnut and the 9/16" wrench as shown.



TIPS STEP 2:

Attach the plusnut in the hole by turning the bolt forward using an impact with a 7/16" socket until the plusnut locks, then remove the bolt by turning the impact in reverse.

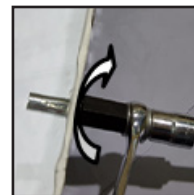

FORWARD



REVERSE

PHASE 2 – INSTALLATION

2.2 VEHICLE PREPARATION

2.2.1 Removing handle.

NOTE: If you are installing a Contoured Partition and your Promaster City is supplied with an oversized sliding door handle, this handle must be removed in order for the door to close properly.

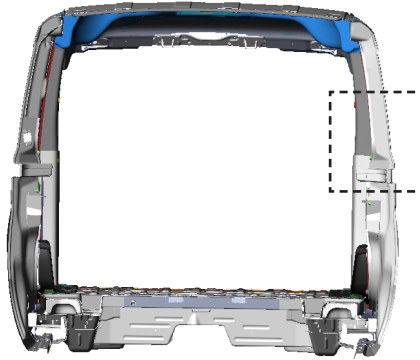

Separate the two halves of the handle exposing the two bolts at the top by removing the small philips screws and the bolt at the bottom.

TOOLS

- Cordless Impact or Ratchet
- Philips Screw Driver
- T30 Torque Bit



Detach the plastic bracket on the cable from the metal part of the handle, then slide the cable across the channel and pop out.

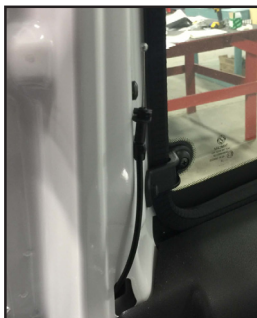

Tape or roll the cable.

NOTE: Pulling the cable unlocked the door.

2.2.2 Removing overhead plastic.

NOTE: There are two types of covers.

(White Covers - Without OEM partition, and Black Covers - With OEM partition)

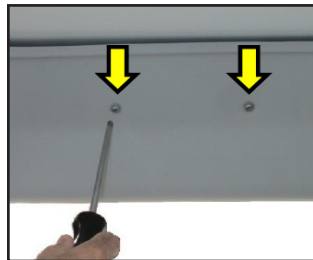
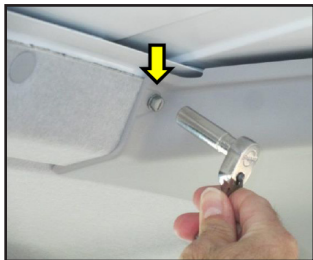
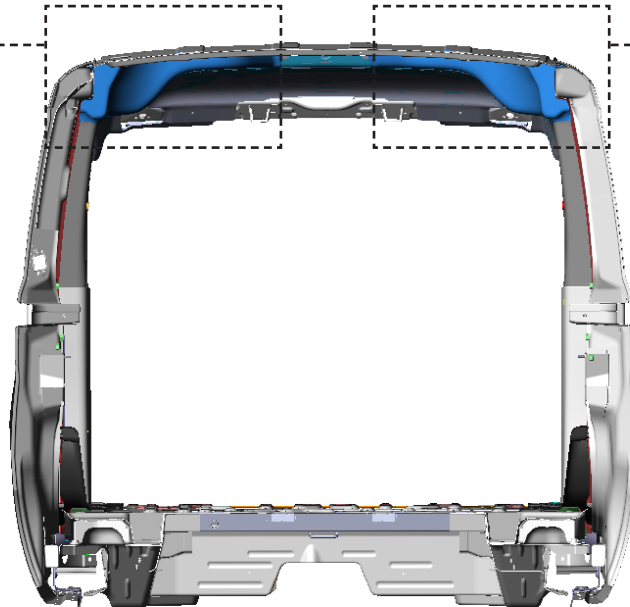

For the white cover, remove the two screws on the side and bolt on the front.

NOTE: Do these on both sides of the van.

TOOLS

- Cordless Impact or Ratchet
- Phillips Screw Driver
- 7/16" Socket

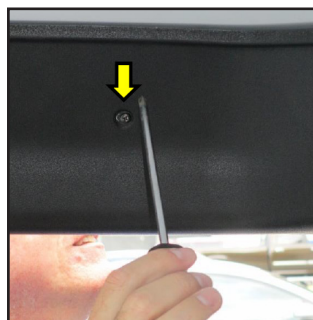

For the black cover, remove the screw on the side and bolt on the front.

NOTE: Do these on both sides of the van.

TOOLS

- Cordless Impact or Ratchet
- Phillips Screw Driver
- 7/16" Socket

2.2.3 Driver and passenger sides preparation.

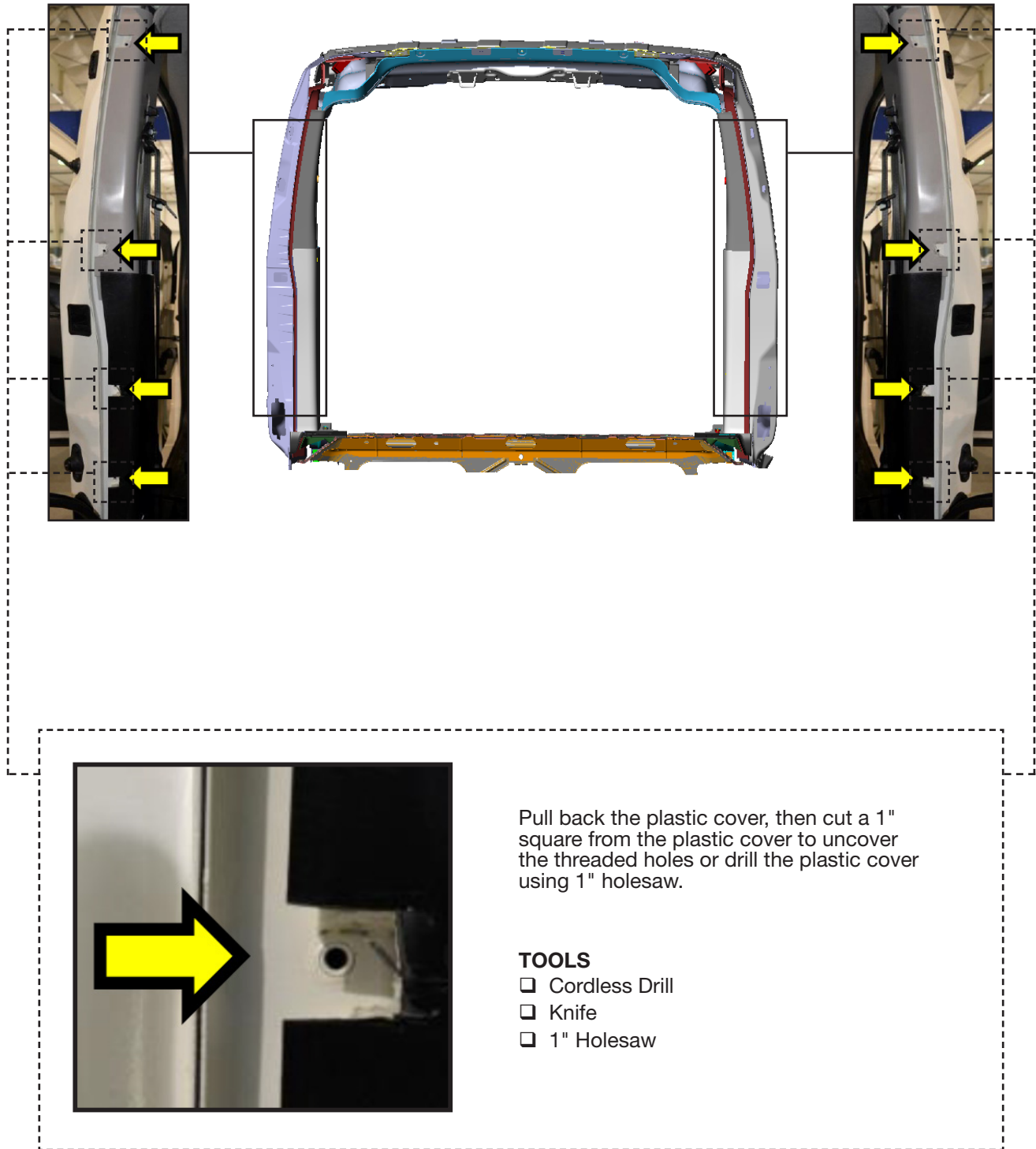

2.2.4 Ceiling and floor preparation.

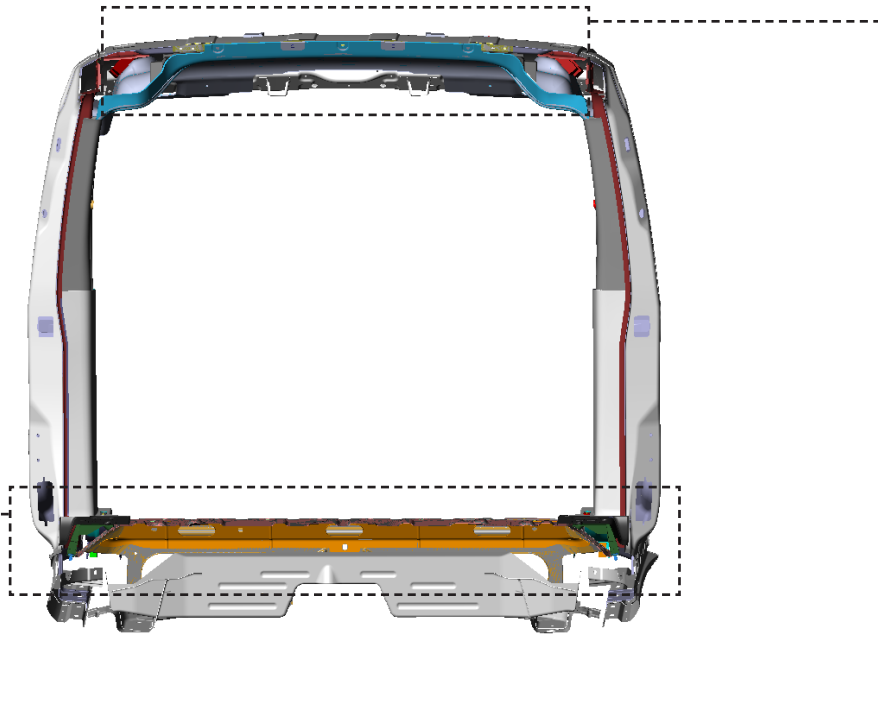

Attach plusnut on these 5 holes.

NOTE: Enlarge these holes if the plusnuts don't fit, using 3/8" drill bit or step drill.

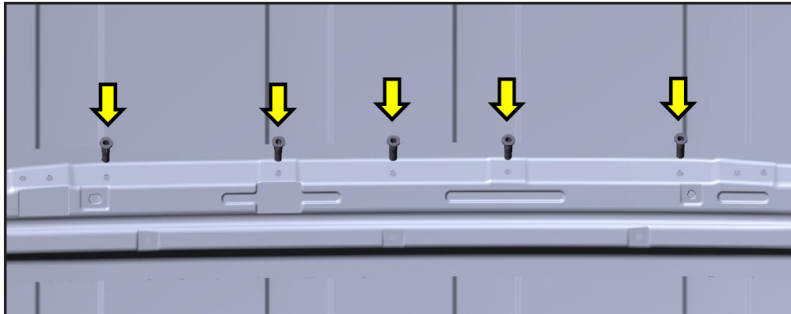

TOOLS

- Plusnut Tool

HARDWARE USED

5x



94-130
Plusnut .250

Remove plastic caps and the two D-rings from vehicle floor, then verify if the threads are in good condition.

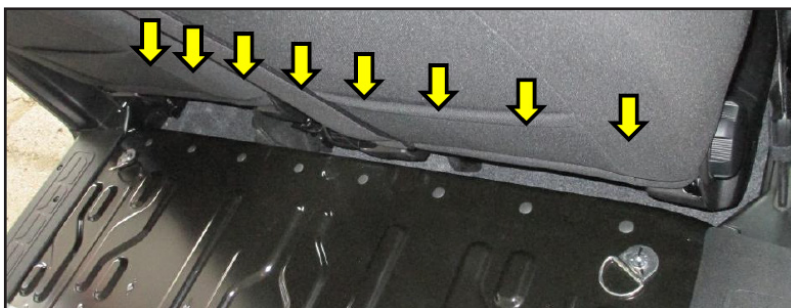

TOOLS

- Cordless Impact
- T40 Torque Bit

PHASE 2 – INSTALLATION

2.3 CONTOURED PARTITION INSTALLATION

2.3.1 Attach the floor bracket in the van.

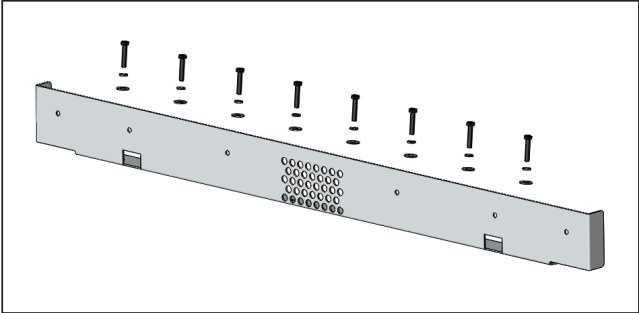



TOOLS

- Cordless Impact
- 13mm Socket

HARDWARE USED

8x

-  #90-668 Hex Bolt M8 x 40
-  #98-122 Lock Washer
-  #98-116 Flat Washer

2.3.2 Lift the assembled partition in the van, then bolt both sides of the partition in the van.

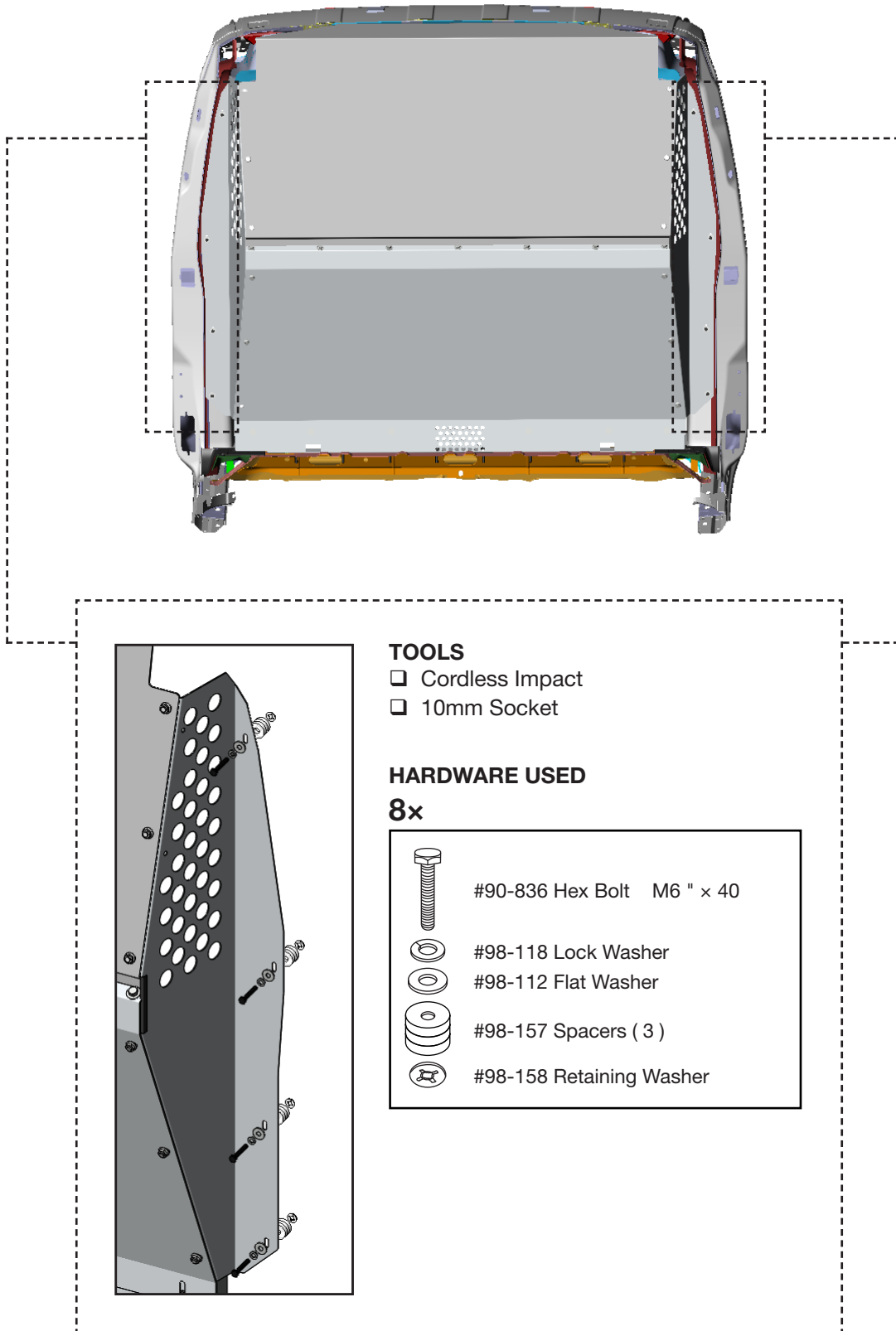

2.3.3 Attach the upper panel in the van, then attach the lower panel to the floor bracket.

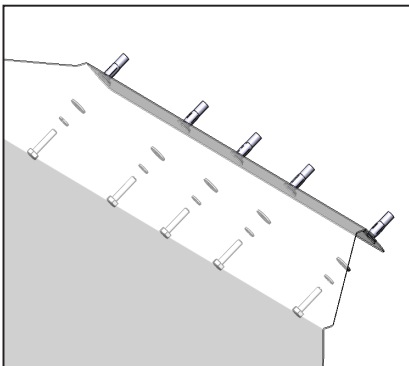
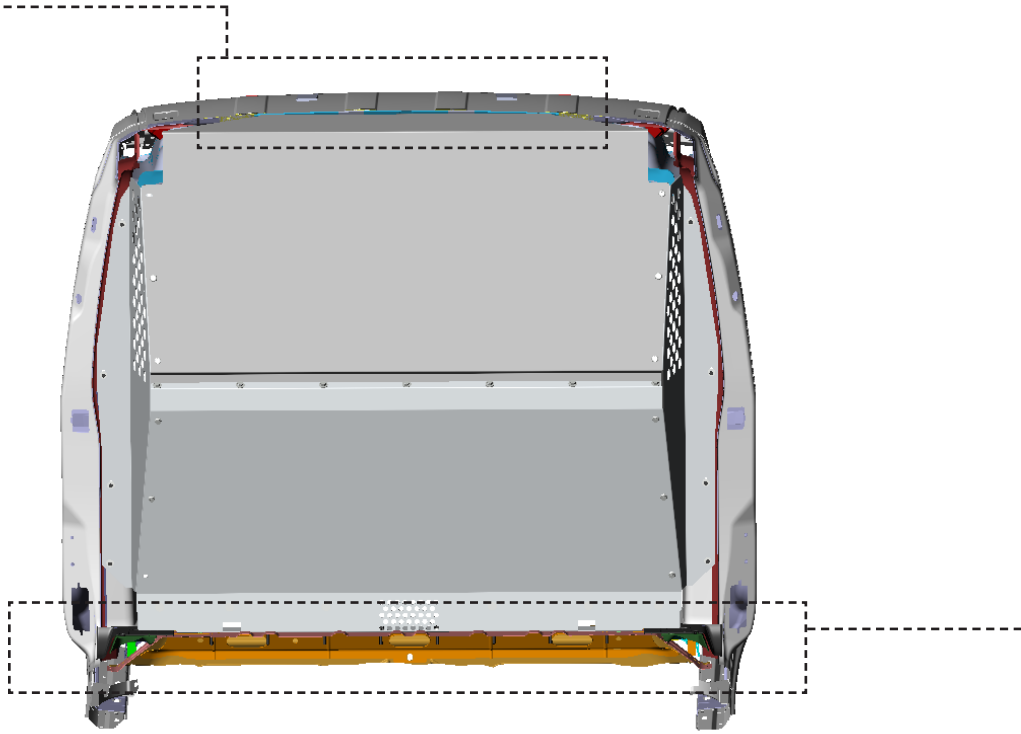

TOOLS

- ☐ Cordless Impact
- ☐ 7/16" Socket

HARDWARE USED

5x

-  #90-118 Hex Bolt 1/4" x 1-1/4"
-  #98-118 Lock Washer
-  #98-112 Flat Washer

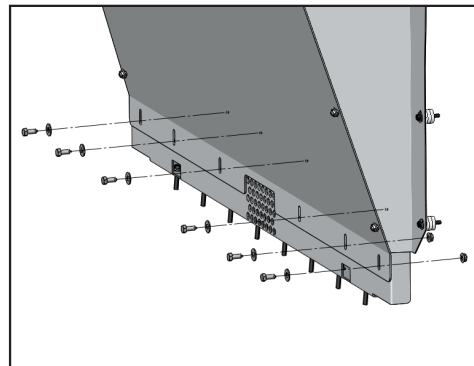



TOOLS

- ☐ Cordless Impact
- ☐ 1/2" Socket

HARDWARE USED

6x

-  #90-204 Hex Bolt 5/16" x 3/4"
-  #98-116 Flat Washer
-  #94-116 Serrated Nut

2.3.4 Apply the warning label on the upper panel.

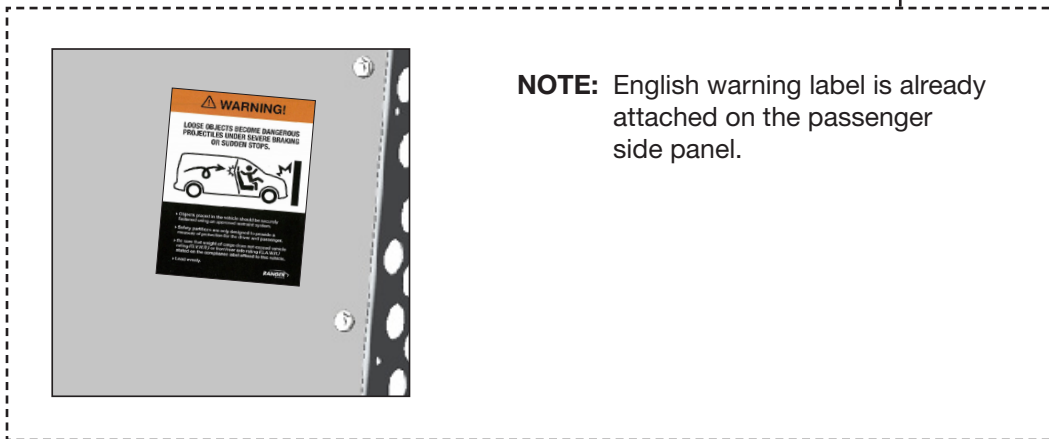
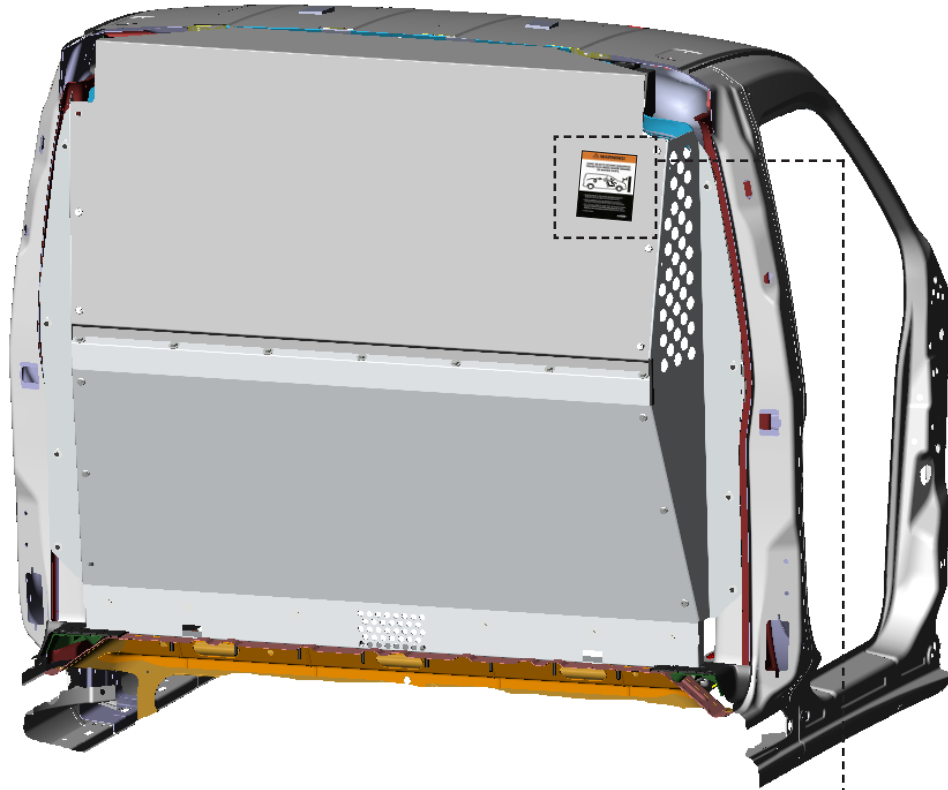

NOTE: English warning label is already attached on the passenger side panel.



**“Congratulations, you have successfully installed your
Contoured Partition!”**

Thank you for doing business with us.”

