

INSTALLATION GUIDE

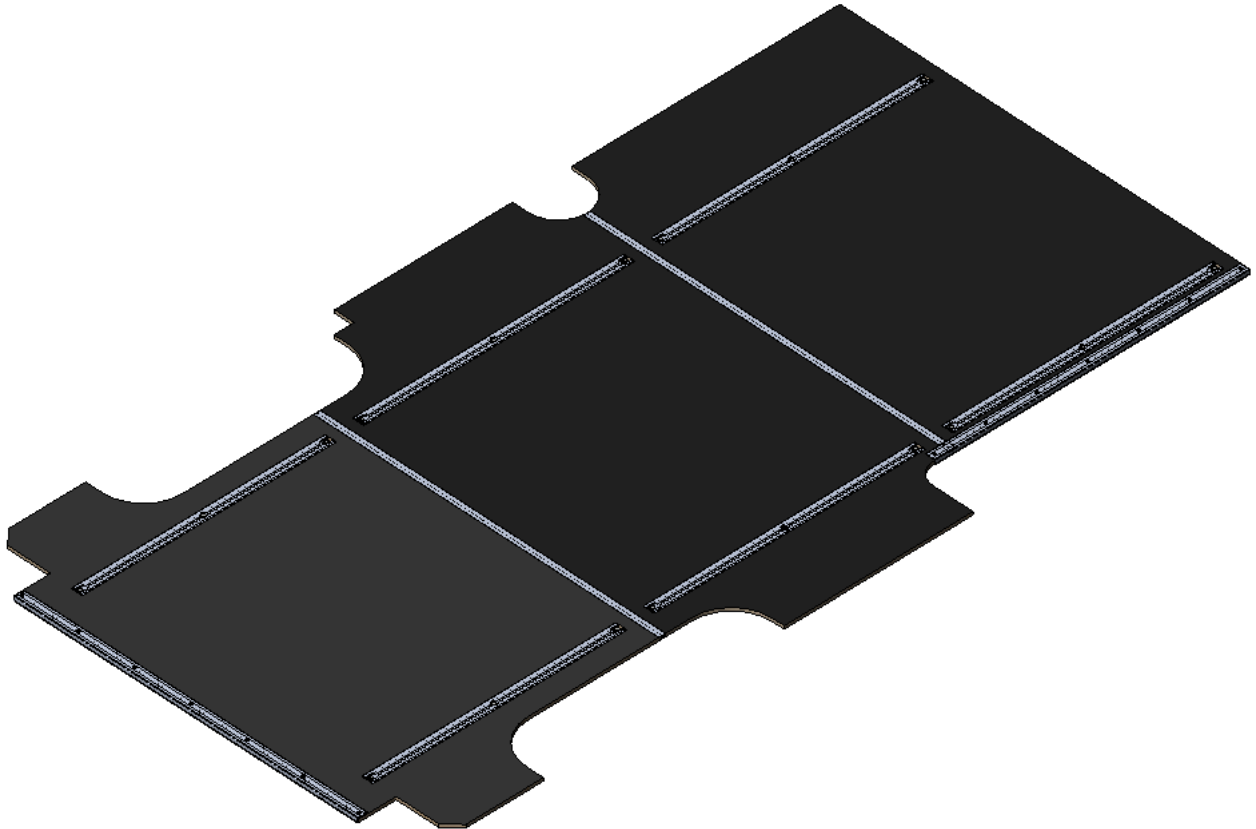

6540-GSX FLOOR

GM Savana (Extended Wheelbase)

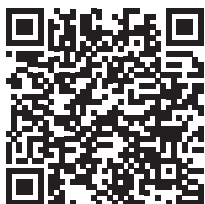

Scan the QR for the latest Install-Guide.





BEFORE YOU BEGIN

READ, UNDERSTAND, AND FOLLOW ALL WARNINGS AND INSTRUCTIONS BEFORE USING THIS PRODUCT. FAILURE TO FOLLOW THESE DIRECTIONS MAY RESULT IN PROPERTY DAMAGE, SERIOUS BODILY INJURY, AND/OR DEATH. RANGER DESIGN IS NOT RESPONSIBLE FOR ANY PROPERTY DAMAGE, PERSONAL INJURY, OR DEATH THAT OCCURRED WHILE USING ANY RANGER DESIGN PRODUCTS.



WARNING

- Failure to use Ranger Design-provided fasteners, brackets, and proper installation guidelines could increase risk of serious personal injury and/or death.
- If drilling is required to complete this installation: improper drilling can cause property damage to vehicles and could lead to electric shock, fire, or even death.
- If drilling is required to complete this installation: Ensure that drilling is only performed on areas of the vehicle allowed by the vehicle's Original Equipment Manufacturer's Body Builders Layout Book (or equivalent document).
- Prior to installation, inspect the vehicle to ensure that installation will not interfere with, or cause obstruction of, any critical components such as electrical wiring, fuel tanks, fuel-cells, locks, latches, etc.
- The installer or manufacturer is responsible for ensuring anchorages are installed onto suitable wall and floor structures; wall and floor strength must meet applicable performance requirements.
- Do not install systems into any weak or unsound materials such as plastics, woods, thin-walled metals, etc. without proper reinforcement.
- Do not install this product where it could interfere with the deployment of airbags. Failure to comply could result in death or serious injury.
- Do not install this product where it could ingress on the Transit Occupant Protection Zone. Failure to comply could result in death or serious injury.
- Incorrect installation could cause water leaks, electric shock or fire.
- Any cargo vehicle with any cargo or equipment should use a certified partition. See Ranger Design website for some partition options. (<https://rangerdesign.com/>)
- Mountings rails are recommended for any attachment to the vehicle walls.
- All items in the cargo area should be properly secured and partition doors closed while the vehicle is in motion.
- Check your vehicle's tare weight and remaining load capacity with all the equipment installed. Never exceed the maximum Gross Vehicle Weight Rating (GVWR), Gross Axle Weight Ratings (GAWRs), or other maximum loads permitted by the vehicle's Original Equipment Manufacturer (OEM) and required by law.
- The heaviest items must be placed towards the bottom of the vehicle, while the lightest ones can be arranged upwards. Vehicle cargo loading weight proportion should follow the following guidelines:

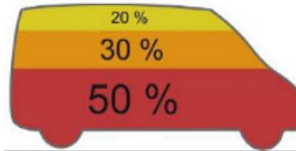

- The final alterer and/ or modifier should review the warning sheet with the customer before the vehicle is released to the customer or for general use. These instructions should remain with the vehicles a all times.
- Any modification or unintended use of this product voids any warranty and could create a hazardous condition.
- Ranger Design provides recommended assembly and installation instructions which should be followed to ensure correct operation. Failure to do so could result in invalidating the product's compliance, warranty and cause injury. Notwithstanding, the final stage vehicle alterer and/or modifier is responsible for the integration, installation, and compliance of the product in its final location to all applicable regulations and standards. Failure to maintain compliance of the vehicle to applicable regulations and standards could be punishable by law. Alterers and/or modifiers should consult with all local authorities prior to commissioning.



CAUTION

- Drilling is required to complete this installation. Before drilling, ensure that you will not hit any critical parts of the vehicle like the gas tank, wiring harness, or hose. Consult the vehicle OEM documentation as necessary. When drilling, use a drill collar to reduce the risk of damage to the vehicle.
- Any materials, padding, or glazing installed in the vehicle must comply with FMVSS/CMVSS 201/205/302, as applicable.
- In the event of a motor vehicle accident or collision where a Ranger system has been installed, especially ones where the vehicle structure is damaged and/or the air bags deploy and/or the vehicle has been towed, the system must be inspected to ensure continued soundness and safety before returning the vehicle to service. Damaged components should be replaced as necessary.
- All system components should be regularly inspected, cleaned, and maintained pursuant to Ranger guidelines.

QUICK START GUIDE

Phase 1 - Assembly

□ 1.1 Setup.....	4
------------------	---

Phase 2 - Installation

□ 2.1 Floor Installation.....	6
□ 2.2 How To Install Shelving In Ranger Design Floor.....	12

REQUIRED ITEMS

- Cordless Impact
- Tape Measure
- Rubber Mallet
- 7/16" Socket
- Plus Nut Tool
- 3/8" Impact Bit
- Marker
- 3/8" Drill Bit
- Drill Collar (Set at 1/2")
- 1" Hole Saw

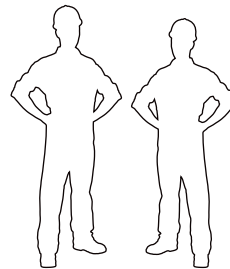

**2
PERSONS**

PHASE 1 – ASSEMBLY

1.1 SETUP

1.1.1 Unpack components; compare with the bill of materials.

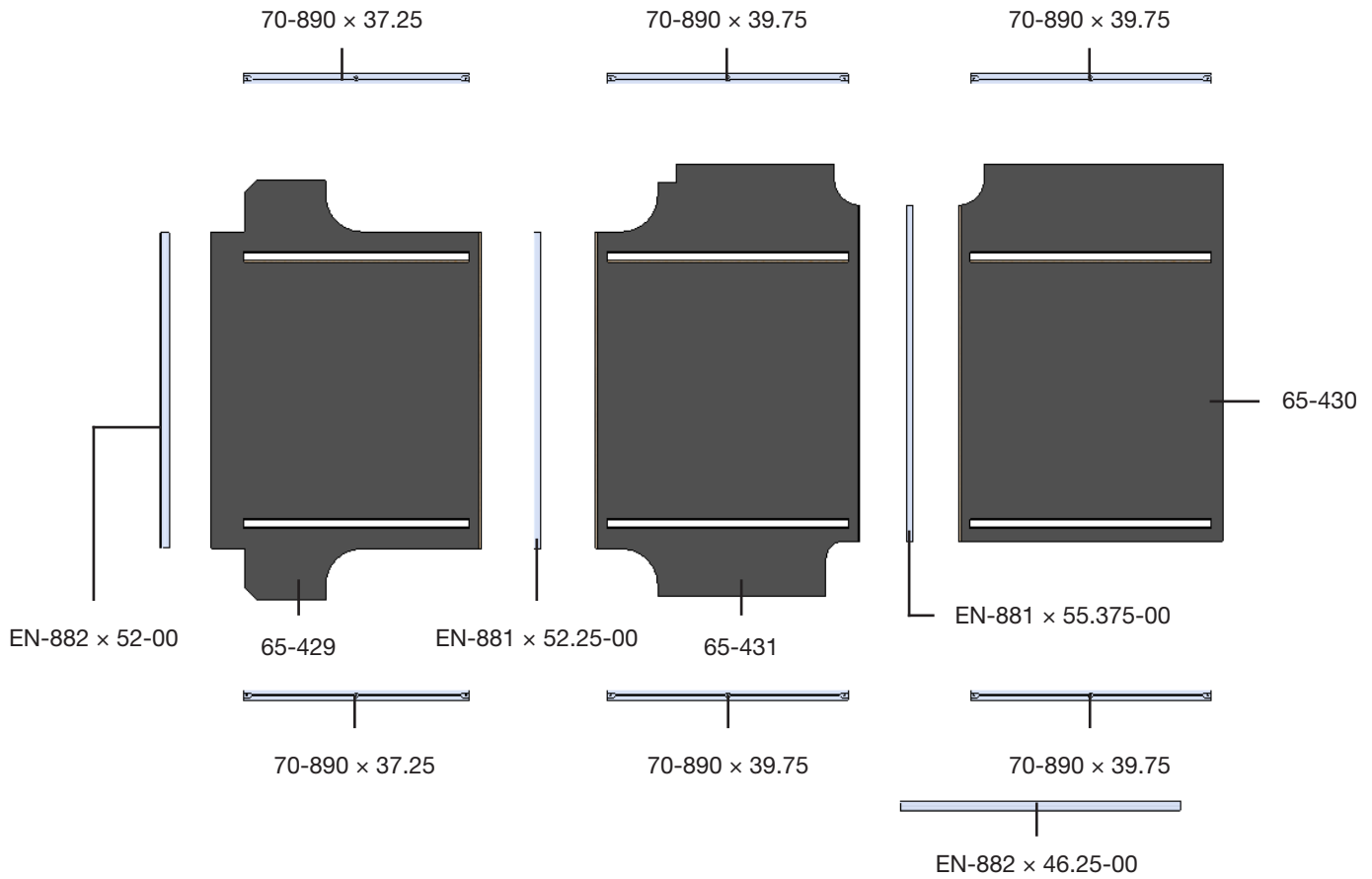

1.1.2 Verify all parts are present.

BILL OF MATERIALS

Item No.	Description	Qty.
65-430	Floor Panel (Front)	1
65-431	Floor Panel (Middle)	1
65-429	Floor Panel (Rear)	1
EN-882 x 52-00	Sill (Rear)	1
EN-882 x 46.25-00	Sill (Side)	1
70-890 x 37.25	Extrusion Machined (37 - 1/4")	2
70-890 x 39.75	Extrusion Machined (39 - 3/4")	4
EN-881 x 52.25-00	I Beam Extrusion (52 - 1/4")	1
EN-881 x 55.375-00	I Beam Extrusion (55 - 3/8")	1
96-6009	Install Fastener Kit	1

1.1.3 Fastener kits.



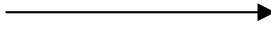

96-6009 Fastener Kit

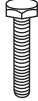

Fastener Install

18x		# 90-114	Hex Bolt 1/4"-20 x 1" ZINC
6x		# 90-490	Bolt Carriage 5/16"-18 x 1" ZINC
6x		# 92-102	Screw #14 x 1" ZINC
14x		# 92-200	Screw #10 x 3/4" ZINC
6x		# 94-104	Hex Nut 5/16" - 18 ZINC
18x		# 94-130	Plus Nut 1/4" - 20
18x		# 98-112	Flat Washer 1/4", O.D. 3/4" ZINC
6x		# 98-116	Flat Washer 5/16", O.D. 7/8" ZINC
18x		# 98-118	Lock Washer 1/4" ZINC
6x		# 98-122	Lock Washer 5/16" ZINC
18x		# 98-157	Spacer 0.375" ID, 1" OD, 0.250" Thick Nylon





18x

 #90-114 Hex Bolt 1/4" x 1"
 #98-118 Lock Washer
 #98-112 Flat Washer
 #98-157 Spacer
 #94-130 Plus Nut

14x

 #92-200 Screw 3/4"

6x FOR SHELVING INSTALLATION

 #90-490 Carriage Bolt 5/16" x 1"
 #98-116 Lock Washer
 #98-122 Flat Washer
 #94-104 Hex Nut

6x FOR SHELVING INSTALLATION

 #92-102 Screw 1"

PHASE 2 – INSTALLATION

2.1 FLOOR INSTALLATION

2.1.1 Lift the three floor panels into the van, starting with the front panel, and attach together with the two EN-881 I beam extrusions.

NOTE: Make sure that the I beam extrusions are centered to the floor panels.

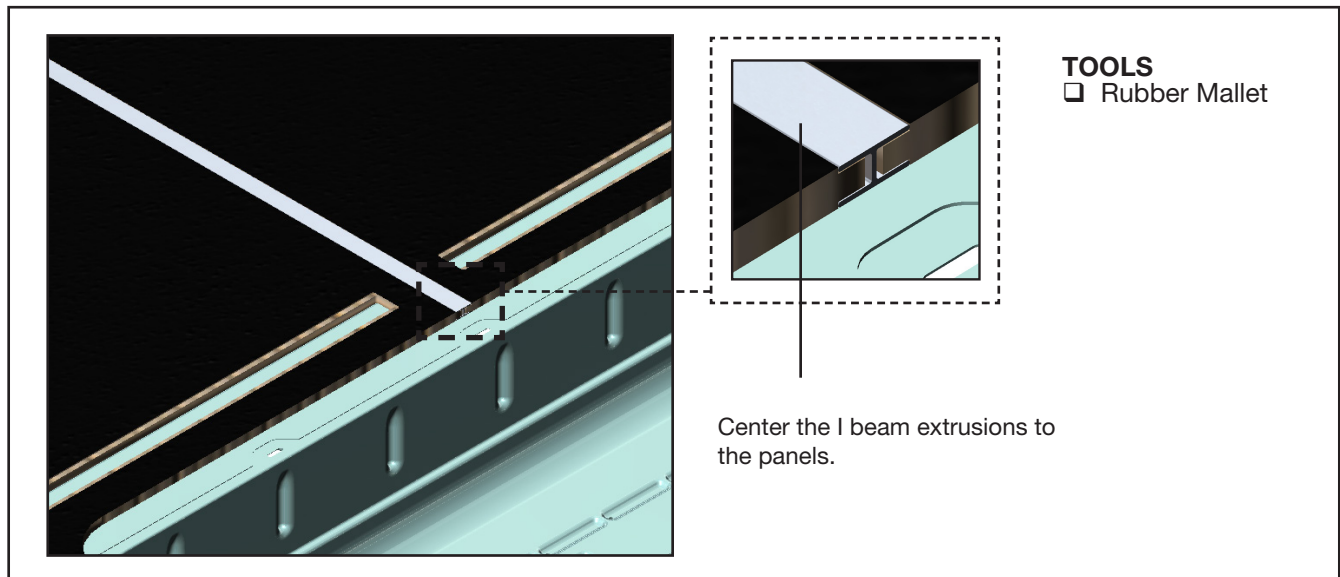
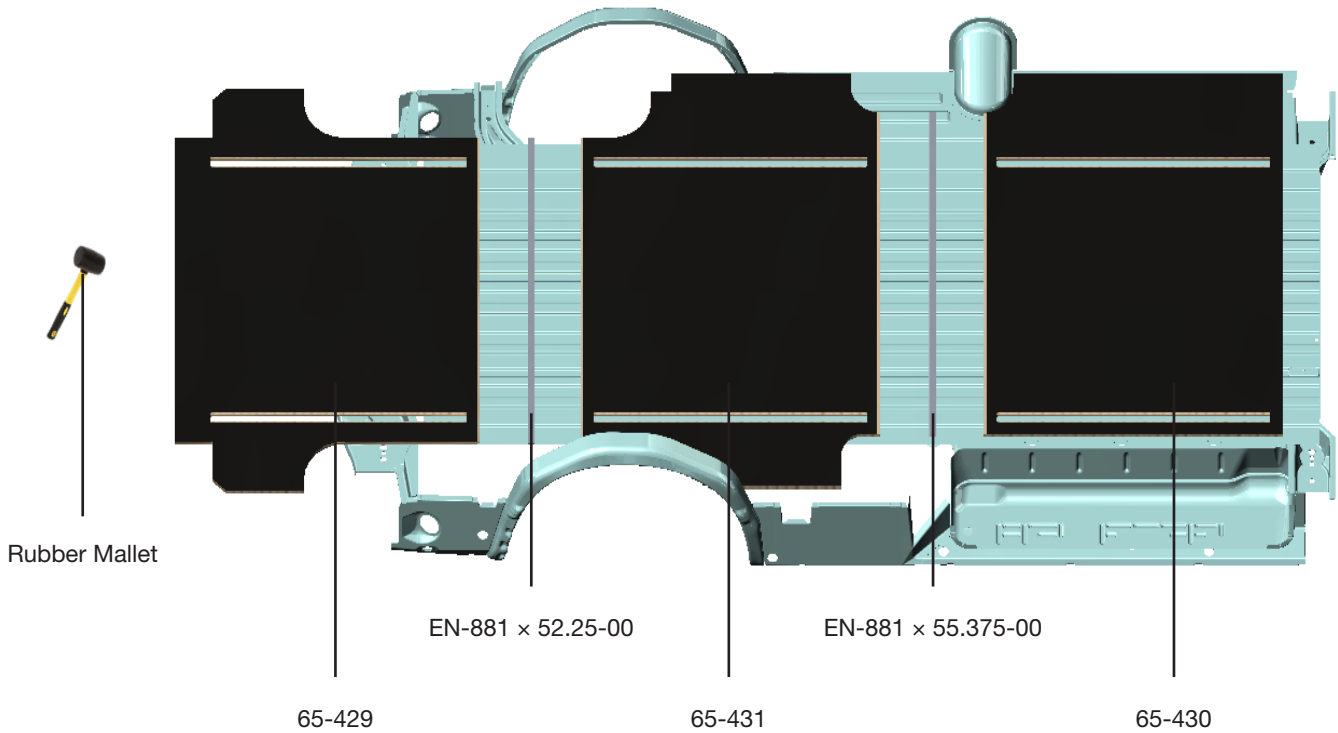

2.1.2 Screw the side sill to the floor panel.

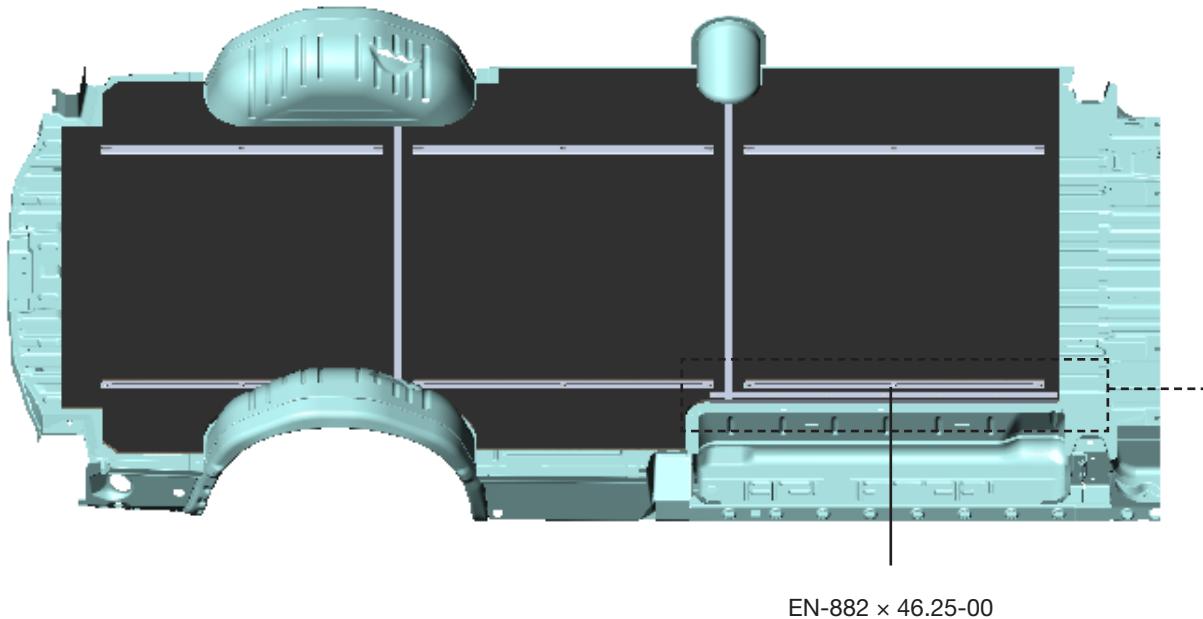

TOOLS

- ☐ Cordless Impact
- ☐ 3/8" Impact Bit

HARDWARE USED

7x

	#92-200 Screw 3/4"
---	--------------------

2.1.3 Screw the rear sill to the floor panel.

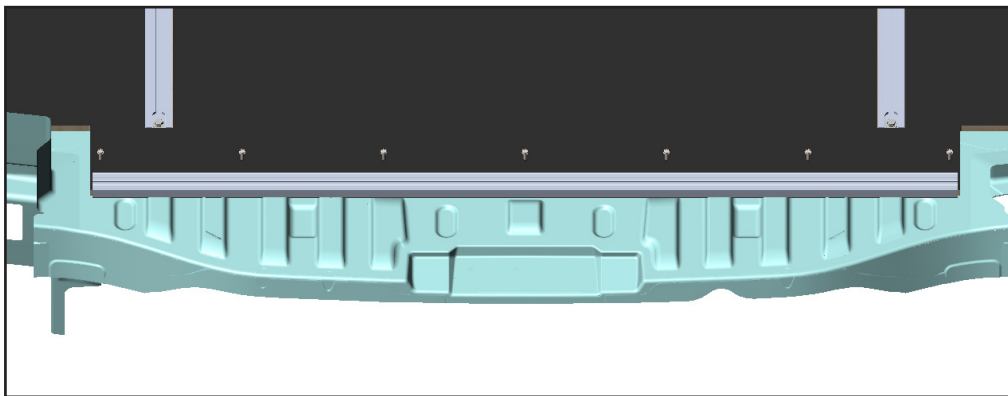
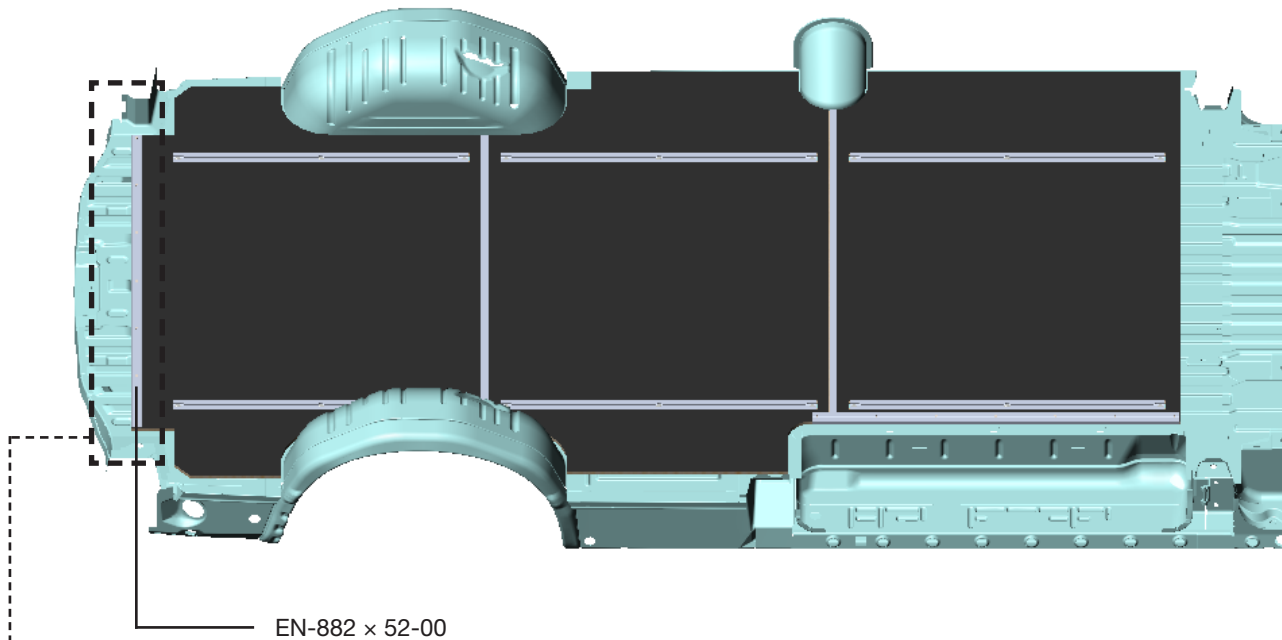

TOOLS

- Cordless Impact
- 3/8" Impact Bit

HARDWARE USED

7x



#92-200 Screw 3/4"

- 2.1.4** • Put the 37 - 1/4", 39 - 3/4" extrusions in place, then mark all the holes.
 • Remove the extrusions, then drill all the marks.

NOTE: Before drilling, ensure that you will not hit any critical parts of the vehicle like the **Gas tank**, **Wiring Harness** and **Hose**.

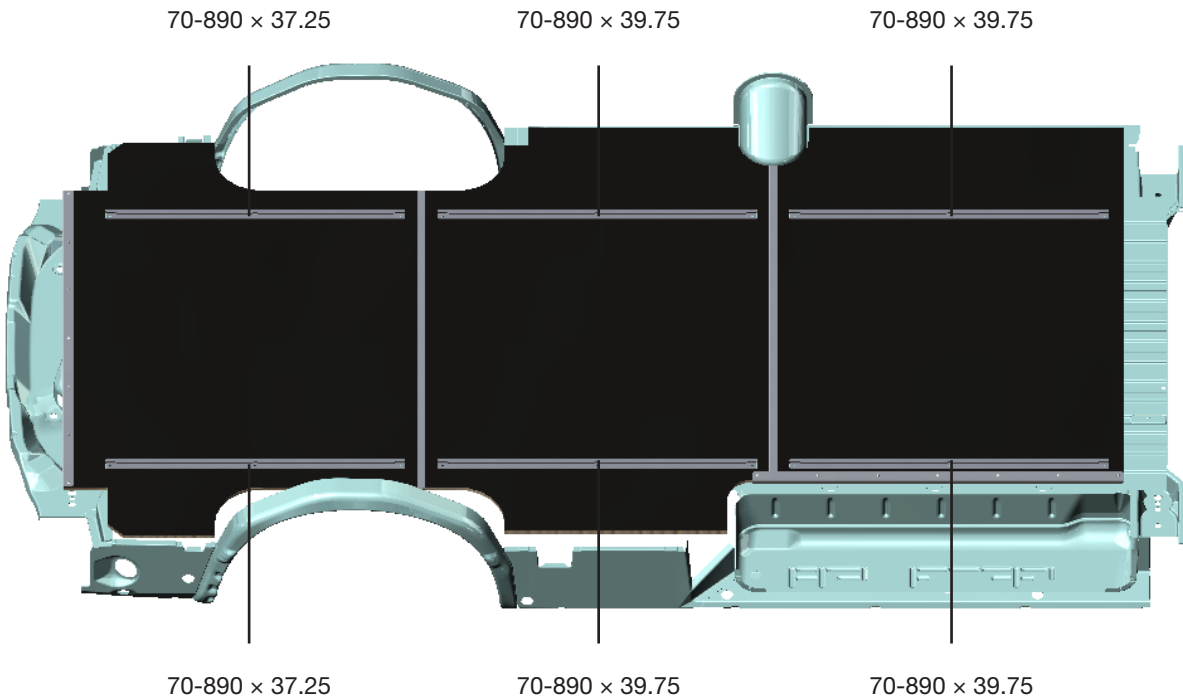

	<p>Mark all the holes</p>
	<p>NOTE: If the mark is on the plastic cover, use 1" hole saw to drill the plastic cover, then use 3/8" drill bit with drill collar to drill the floor.</p> <p>TOOLS</p> <ul style="list-style-type: none"> <input type="checkbox"/> Cordless Drill <input type="checkbox"/> 3/8" Drill Bit <input type="checkbox"/> Drill Collar (Set at 1/2") <input type="checkbox"/> 1" Hole Saw

2.1.5 Attach plus nuts on the holes.

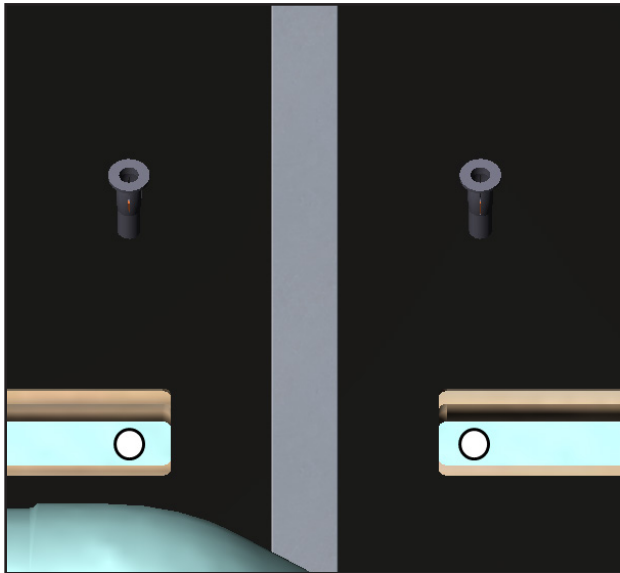
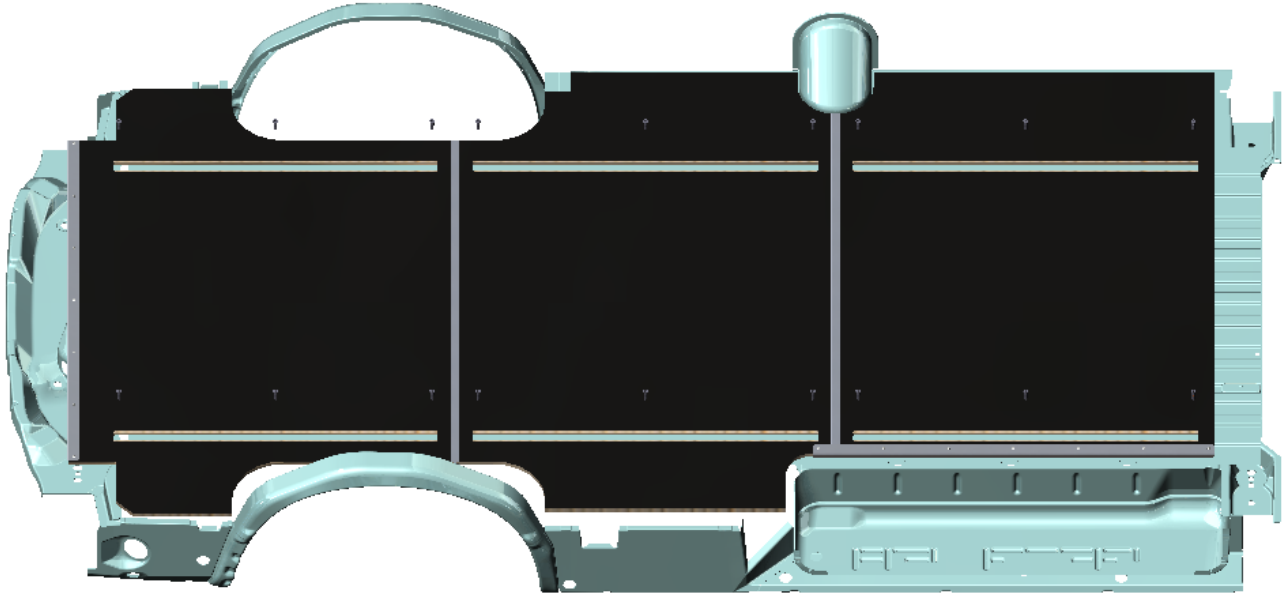

TOOLS
☐ Plus Nut Tool

HARDWARE USED
18x



#94-130 Plus Nut .250

2.1.6 Attach the 37 - 1/4" and 39 - 3/4" extrusions.

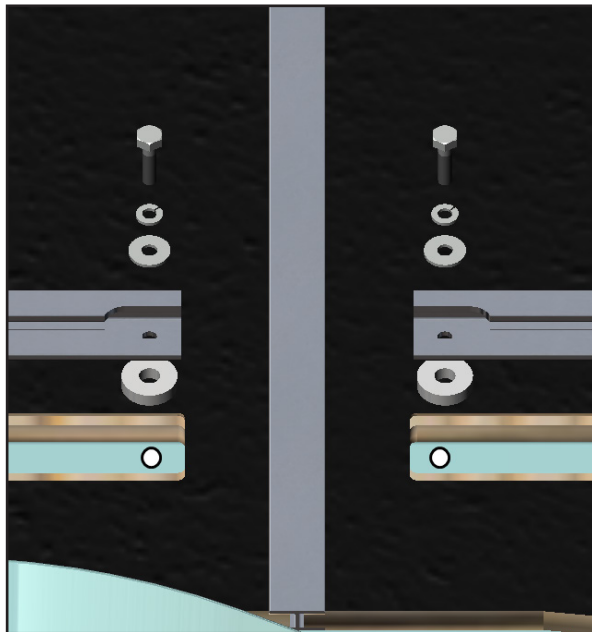
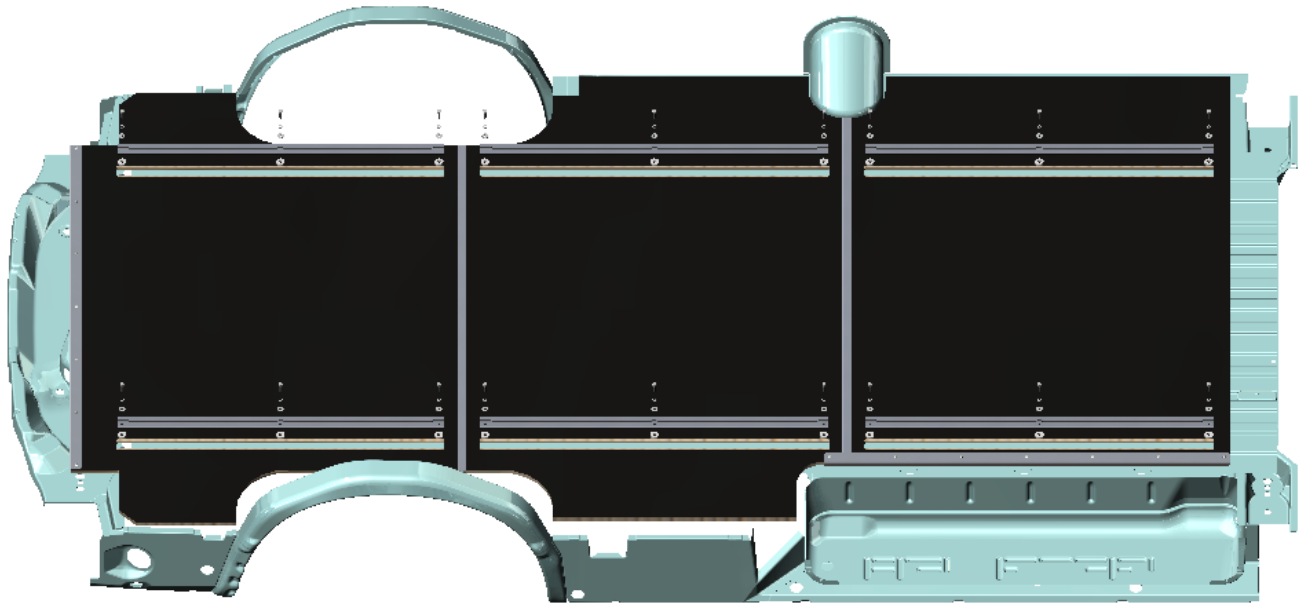





TOOLS

- ☐ Cordless Impact
- ☐ 7/16" Socket

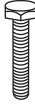
HARDWARE USED

18x

-  #90-114 Hex Bolt 1/4" x 1"
-  #98-118 Lock Washer
-  #98-112 Flat Washer
-  #98-157 Spacer
-  #94-130 Plus Nut (Already Installed)

PHASE 2 – INSTALLATION

2.2 HOW TO INSTALL SHELVING IN RANGER DESIGN FLOOR

- 2.2.1**
- Lift the shelving unit inside the van, then put it in place.
 - Enlarge the holes in the shelving end panels that aligned to the mounting tracks using 3/8" drill bit.
 - Install the shelving unit to the floor mounting track by sliding bolts in the mounting tracks, and putting screws in the last rear hole of the end panels of the shelving unit.

NOTE: After installing the shelf unit to the floor install the shelf brackets to the vehicle.

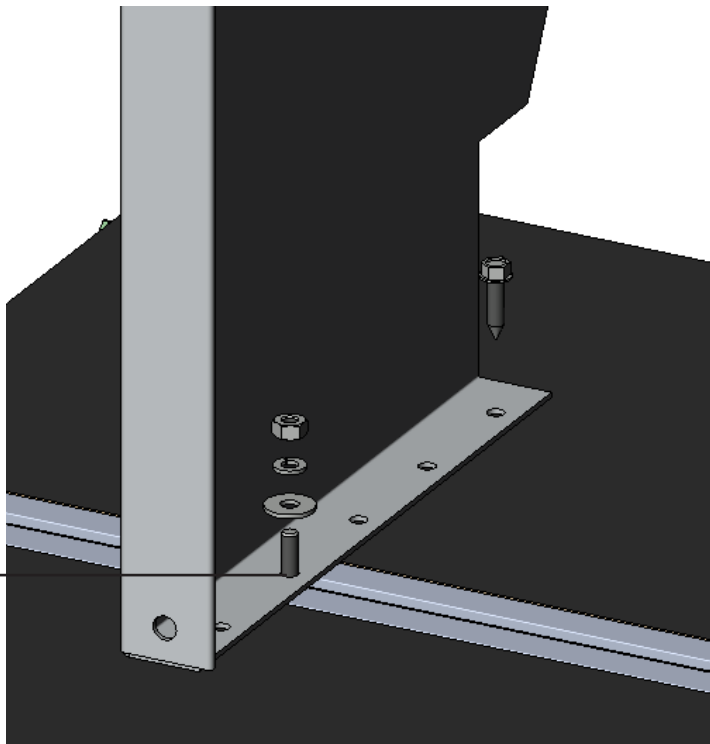
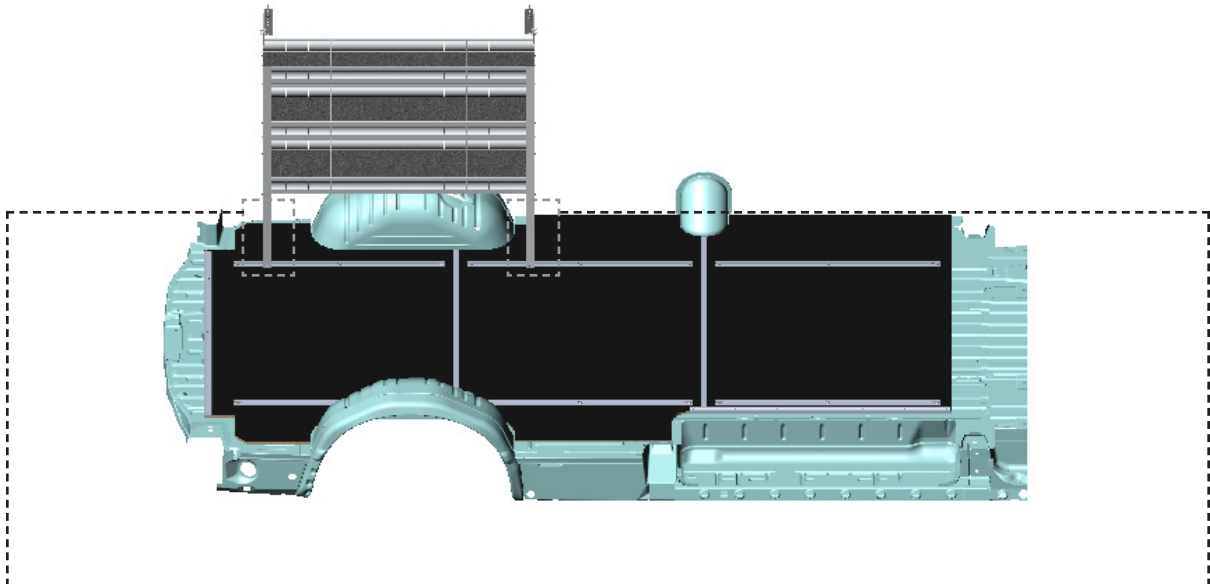

TOOLS

- Cordless Impact
- 3/8" Impact Bit
- 1/2" Socket
- 5/16" Drill Bit

HARDWARE USED

2x



#92-102 Screw 1"

HARDWARE USED

2x



#90-490 Carriage Bolt 5/16" x 1"



#98-116 Lock Washer



#98-122 Flat Washer



#94-104 Hex Nut

Enlarge the hole that aligned to the mounting track using 3/8" drill bit.

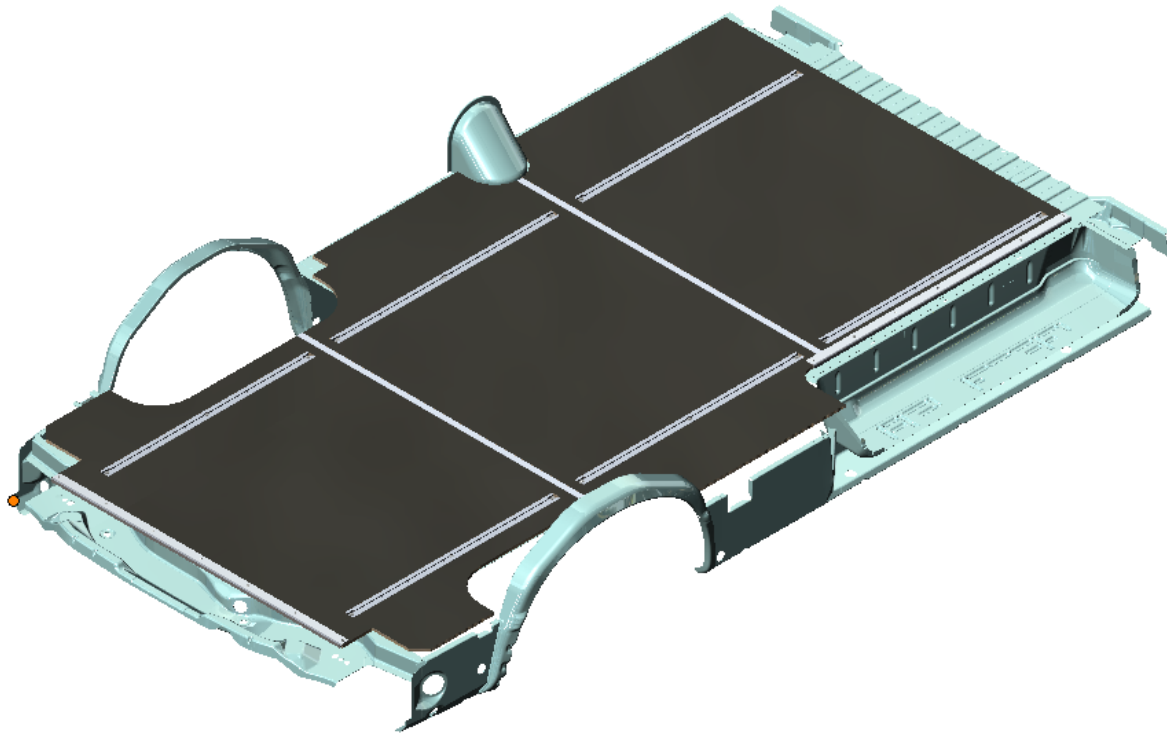

**“You have successfully installed your
Floor**

Thank you for doing business with us.”

For any feedback or suggestions you may have, please contact: cs@rangerdesign.com

