

INSTALLATION GUIDE

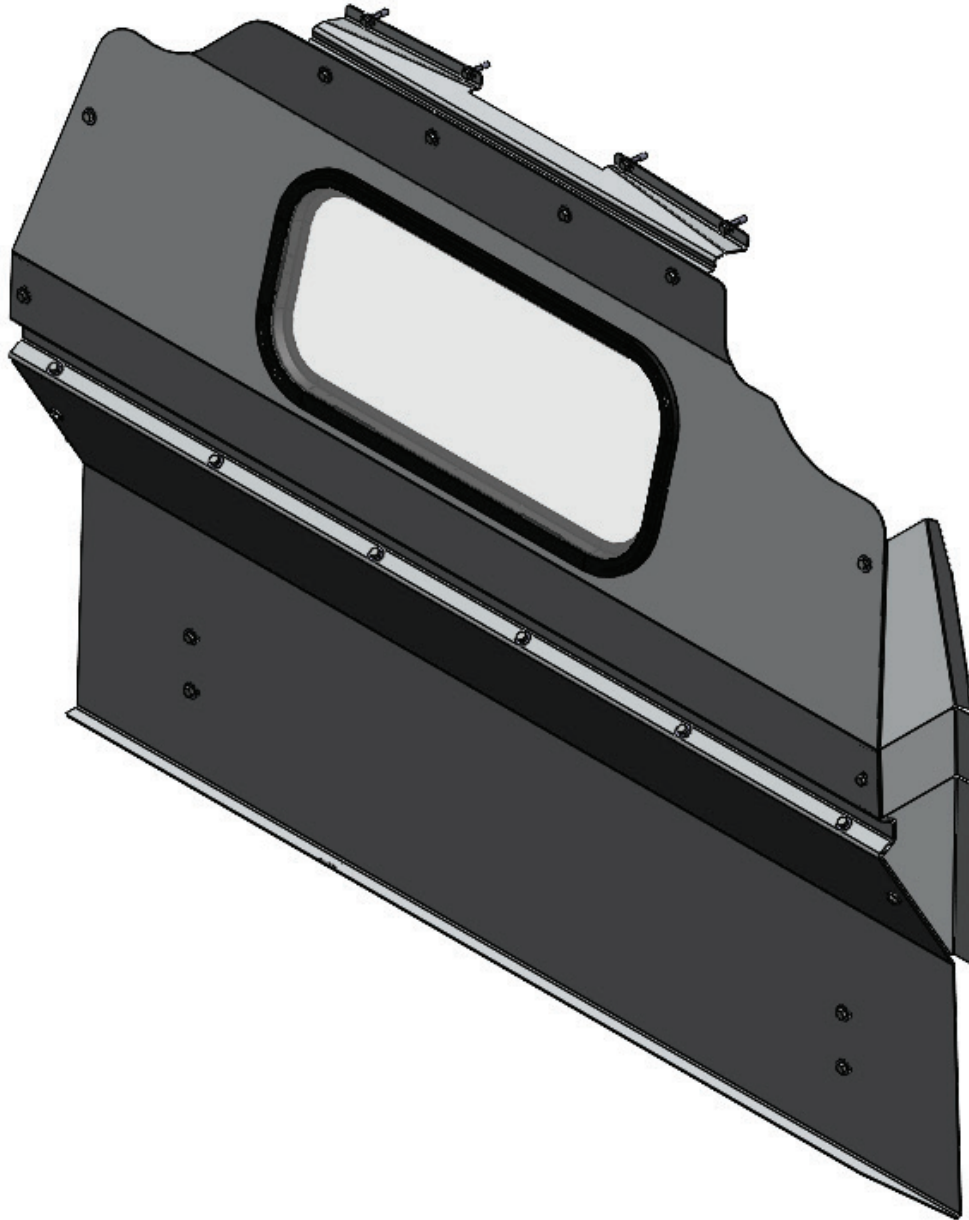

3020-GS CONTOURED PARTITION

Chevrolet Express / GMC Savana (Polycarbonate Window, Aluminum)

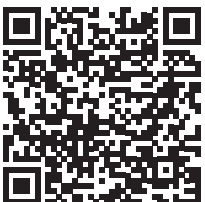

Scan the QR for the latest Install-Guide.





BEFORE YOU BEGIN

READ, UNDERSTAND, AND FOLLOW ALL WARNINGS AND INSTRUCTIONS BEFORE USING THIS PRODUCT. FAILURE TO FOLLOW THESE DIRECTIONS MAY RESULT IN PROPERTY DAMAGE, SERIOUS BODILY INJURY, AND/OR DEATH. RANGER DESIGN IS NOT RESPONSIBLE FOR ANY PROPERTY DAMAGE, PERSONAL INJURY, OR DEATH THAT OCCURRED WHILE USING ANY RANGER DESIGN PRODUCTS.



WARNING

- Failure to use Ranger Design-provided fasteners, brackets, and proper installation guidelines could increase risk of serious personal injury and/or death.
- If drilling is required to complete this installation: improper drilling can cause property damage to vehicles and could lead to electric shock, fire, or even death.
- If drilling is required to complete this installation: Ensure that drilling is only performed on areas of the vehicle allowed by the vehicle's Original Equipment Manufacturer's Body Builders Layout Book (or equivalent document).
- Prior to installation, inspect the vehicle to ensure that installation will not interfere with, or cause obstruction of, any critical components such as electrical wiring, fuel tanks, fuel-cells, locks, latches, etc.
- The installer or manufacturer is responsible for ensuring anchorages are installed onto suitable wall and floor structures; wall and floor strength must meet applicable performance requirements.
- Do not install systems into any weak or unsound materials such as plastics, woods, thin-walled metals, etc. without proper reinforcement.
- Do not install this product where it could interfere with the deployment of airbags. Failure to comply could result in death or serious injury.
- Do not install this product where it could ingress on the Transit Occupant Protection Zone. Failure to comply could result in death or serious injury.
- Incorrect installation could cause water leaks, electric shock or fire.
- Any cargo vehicle with any cargo or equipment should use a certified partition. See Ranger Design website for some partition options. (<https://rangerdesign.com/>)
- Mountings rails are recommended for any attachment to the vehicle walls.
- All items in the cargo area should be properly secured and partition doors closed while the vehicle is in motion.
- Check your vehicle's tare weight and remaining load capacity with all the equipment installed. Never exceed the maximum Gross Vehicle Weight Rating (GVWR), Gross Axle Weight Ratings (GAWRs), or other maximum loads permitted by the vehicle's Original Equipment Manufacturer (OEM) and required by law.
- The heaviest items must be placed towards the bottom of the vehicle, while the lightest ones can be arranged upwards. Vehicle cargo loading weight proportion should follow the following guidelines:

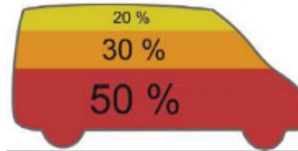

- The final alterer and/ or modifier should review the warning sheet with the customer before the vehicle is released to the customer or for general use. These instructions should remain with the vehicles a all times.
- Any modification or unintended use of this product voids any warranty and could create a hazardous condition.
- Ranger Design provides recommended assembly and installation instructions which should be followed to ensure correct operation. Failure to do so could result in invalidating the product's compliance, warranty and cause injury. Notwithstanding, the final stage vehicle alterer and/or modifier is responsible for the integration, installation, and compliance of the product in its final location to all applicable regulations and standards. Failure to maintain compliance of the vehicle to applicable regulations and standards could be punishable by law. Alterers and/or modifiers should consult with all local authorities prior to commissioning.



CAUTION

- Drilling is required to complete this installation. Before drilling, ensure that you will not hit any critical parts of the vehicle like the gas tank, wiring harness, or hose. Consult the vehicle OEM documentation as necessary. When drilling, use a drill collar to reduce the risk of damage to the vehicle.
- Any materials, padding, or glazing installed in the vehicle must comply with FMVSS/CMVSS 201/205/302, as applicable.
- In the event of a motor vehicle accident or collision where a Ranger system has been installed, especially ones where the vehicle structure is damaged and/or the air bags deploy and/or the vehicle has been towed, the system must be inspected to ensure continued soundness and safety before returning the vehicle to service. Damaged components should be replaced as necessary.
- All system components should be regularly inspected, cleaned, and maintained pursuant to Ranger guidelines.

QUICK START GUIDE

Phase 1 - Assembly

- 1.1 Setup..... 4
- 1.1.1 Unpack components; compare with the bill of materials..... 4
- 1.1.2 Verify all parts are present..... 4
- 1.1.3 Identify the assembly and installation fastener bags..... 5
- 1.2 Partition assembly..... 6
- 1.2.1 Remove all the PVC from all the parts, then attach the upper panel to the lower panel..... 6
- 1.2.2 Attach the edge trim on the contour of the partition..... 6
- 1.2.3 Attach both ceiling brackets on the upper panel and attach both wings to the upper and lower panels..... 7

Phase 2 - Installation

- 2.1 Tips on how to attach a plusnut..... 10
- 2.1.1 Attach plusnut using plusnut gun..... 10
- 2.1.2 Attach plusnut using 6490 plusnut tool..... 10
- 2.2 Vehicle preparation..... 9
- 2.2.1 Driver and passenger sides preparation..... 11
- 2.3 Contoured partition installation..... 8
- 2.3.1 Attach both wings to the van..... 8
- 2.3.2 Screw the lower panel to the van floor and attach both ceiling brackets to the van..... 9
- 2.3.3 Apply the warning label on the upper panel..... 14

REQUIRED ITEMS

- Cordless Impact
- Cordless Drill
- Cutter
- Mallet
- Marker
- Plusnut Tool
- 3/8" Driver Bit
- 3/8" Drill Bit
- 7/16" Socket
- T45 Socket
- 1/2" Socket
- 9/16" Wrench

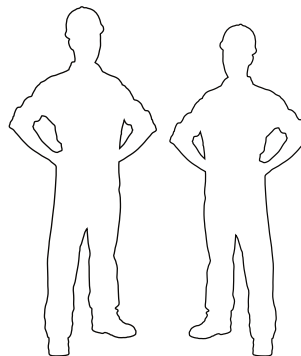

2
PERSONS

PHASE 1 – ASSEMBLY

1.1 SETUP

1.1.1 Unpack components; compare with the bill of materials.

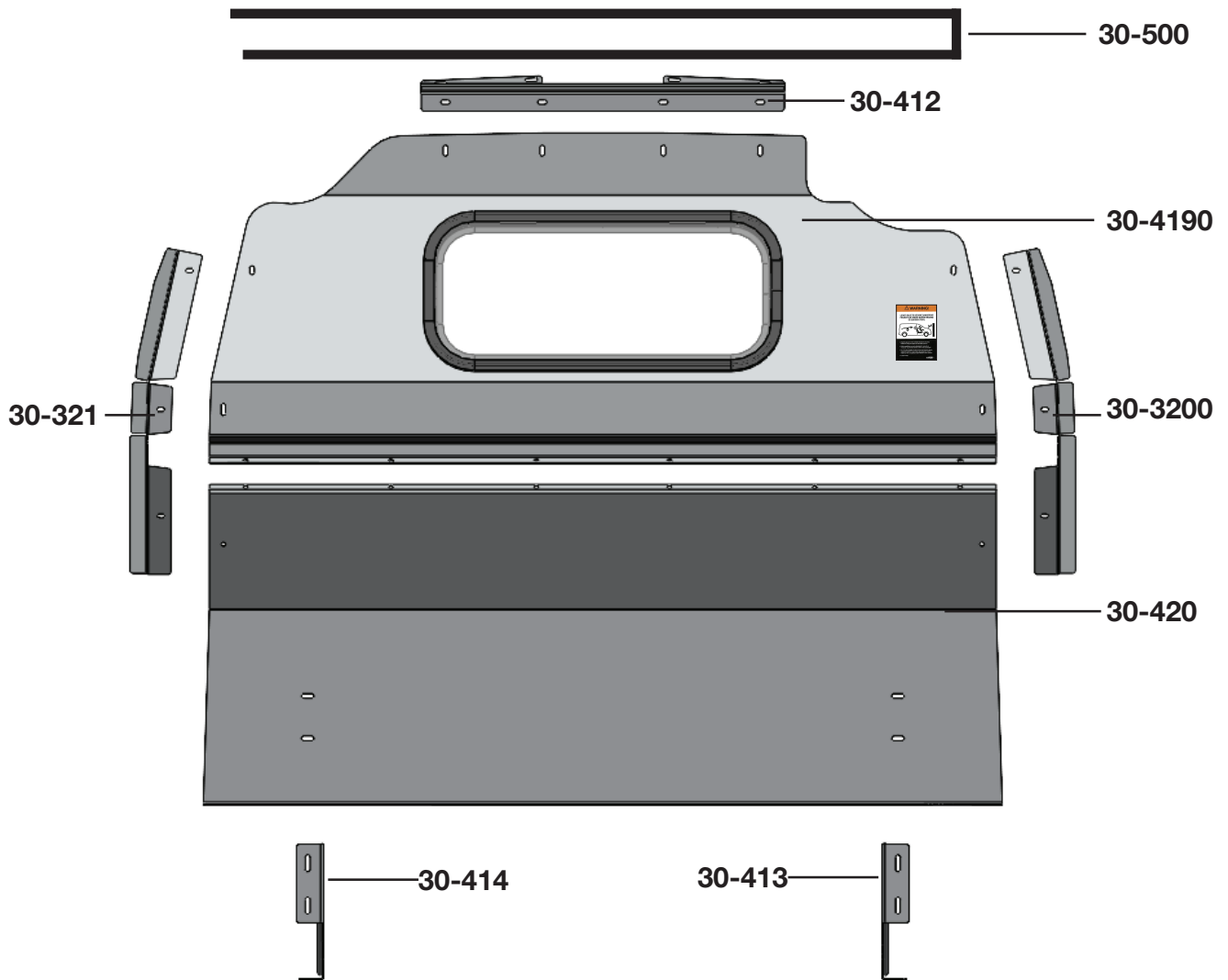

1.1.2 Verify all parts are present.

Item No.	Description	Qty.
30-3200	Passenger Side Wing with Sticker	1
30-321	Driver Side Wing	1
30-412	Roof Bracket	1
30-413	Passenger Side Floor Bracket	1
30-414	Driver Side Floor Bracket	1
30-4190	Upper Panel w/ Window	1
30-420	Lower Panel	1
30-500	Edge Trim (QTY in Inches)	174
79-932	Bilingual Warning Label	1
94-3044	Assembly Fastener Bag	1
96-3030	Installation Fastener Bag	1

1.1.3 Identify the **Assembly** and **Installation** fastener bags.

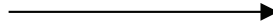

94-3044



Hardware Installation

- 20x  # 90-204 Hex Bolt
5/16"-18 x 3/4"
GR-5 ZINC
- 20x  # 94-116 Serrated Nut
5/16"-18
ZINC
- 20x  # 98-116 Flat Washer
5/16", 7/8" OD
ZINC

20x

 #90-204 Hex Bolt 5/16" x 3/4"
 #98-116 Flat Washer
 #94-116 Serrated Nut



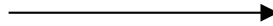

96-3030

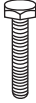

Hardware Installation

- 4x  # 90-114 Hex Bolt
1/4"-20 x 1"
GR-5 ZINC
- 4x  # 94-130 Plusnut .250
- 4x  # 98-112 Flat Washer
1/4", 3/4" OD
ZINC
- 4x  # 98-118 Lock Washer
Regular 1/4"
ZINC

4x

 #90-114 Hex Bolt 1/4" x 1"
 #98-118 Lock Washer
 #98-112 Flat Washer
 #94-130 Plusnut .250

PHASE 1 – ASSEMBLY

1.2 PARTITION ASSEMBLY

1.2.1 Remove all the PVC from all the parts, then attach the upper panel to the lower panel.

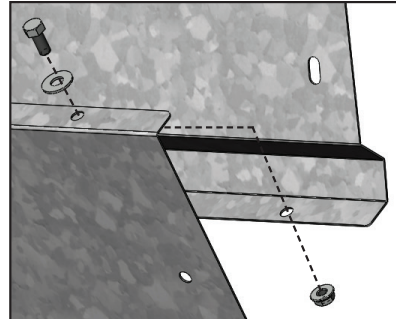
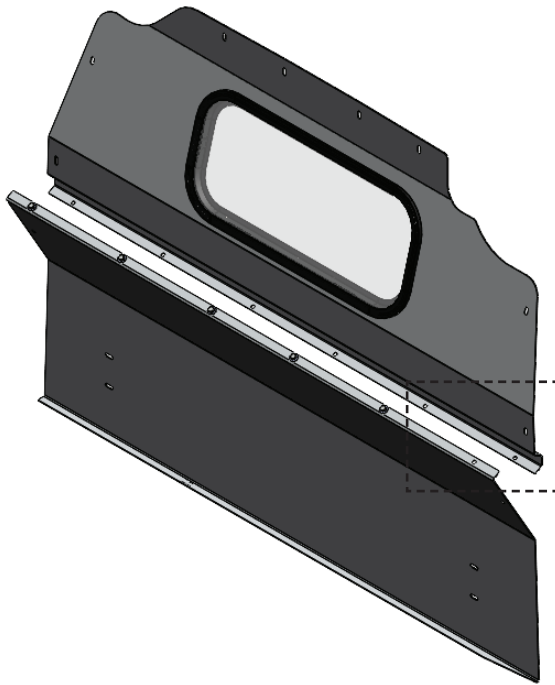

TOOLS

- Cordless Impact
- Knife
- 1/2" Socket

HARDWARE USED

6x



#90-204 Hex Bolt 5/16" x 3/4"



#98-116 Flat Washer



#94-116 Serrated Nut

1.2.2 Attach the edge trim on the contour of the partition.

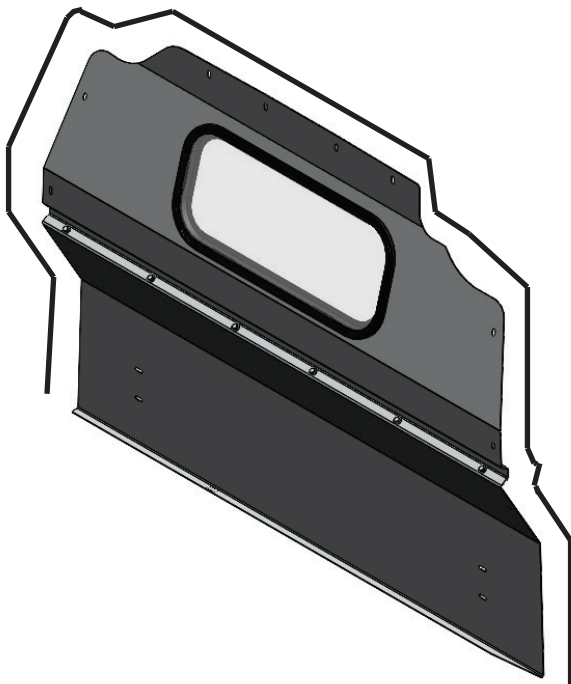

TOOLS

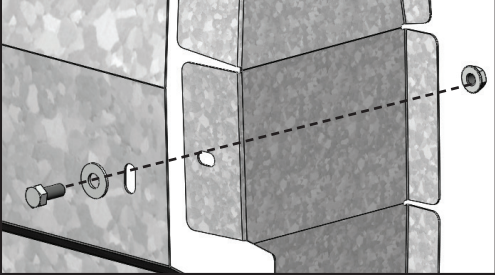
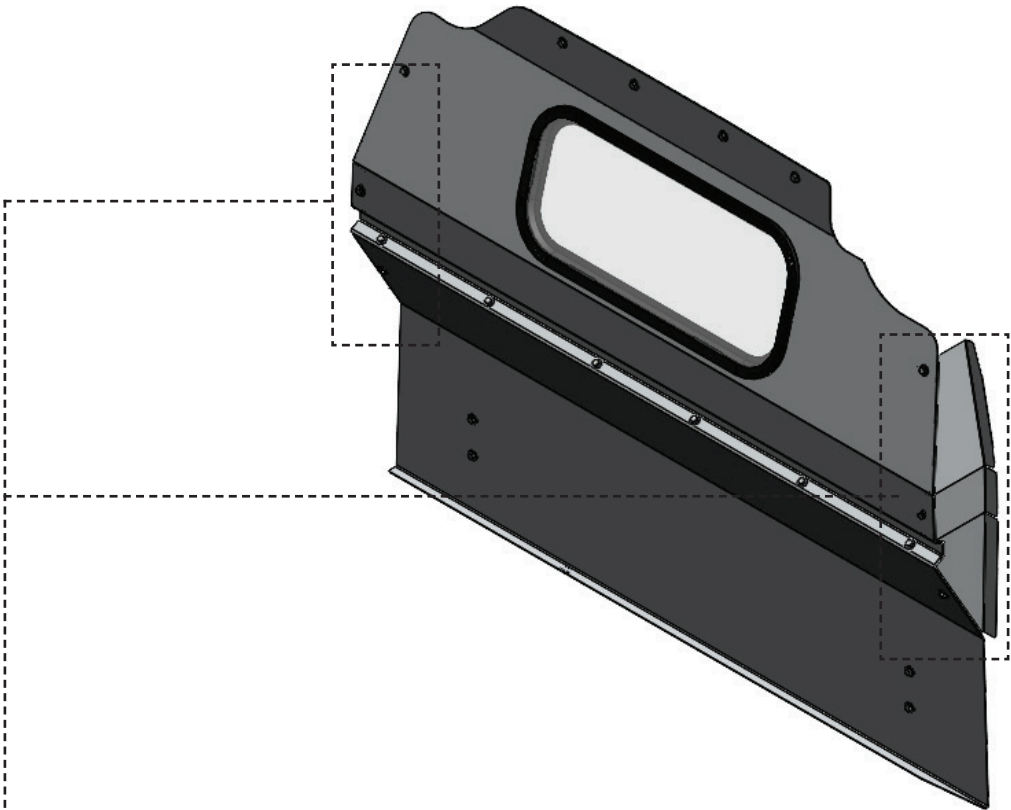

- Mallet
- Cutter

1.2.3 • Attach both wings to the upper and lower panels.



HARDWARE USED

6x

	#90-204 Hex Bolt 5/16" x 3/4"
	#98-116 Flat Washer
	#94-116 Serrated Nut

2.2 INSTALLATION

2.2.1 Floor bracket installation preparation.

Roll up floor mat to reveal factory provided D-Rings.

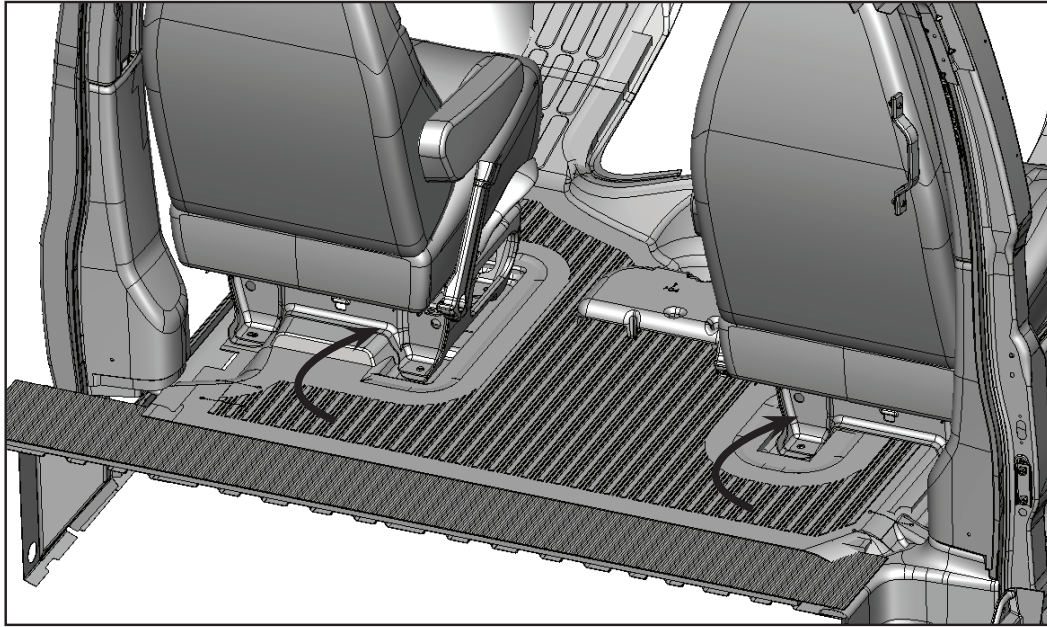

Remove D-Rings and put aside for later use.

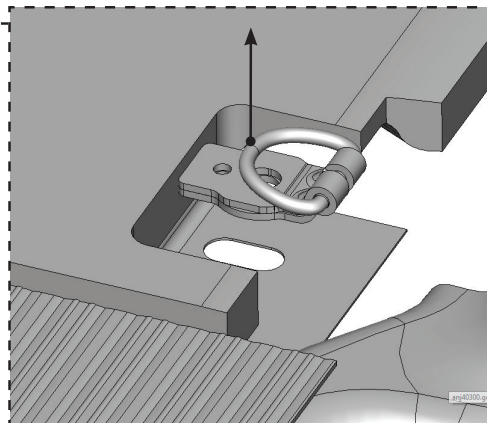
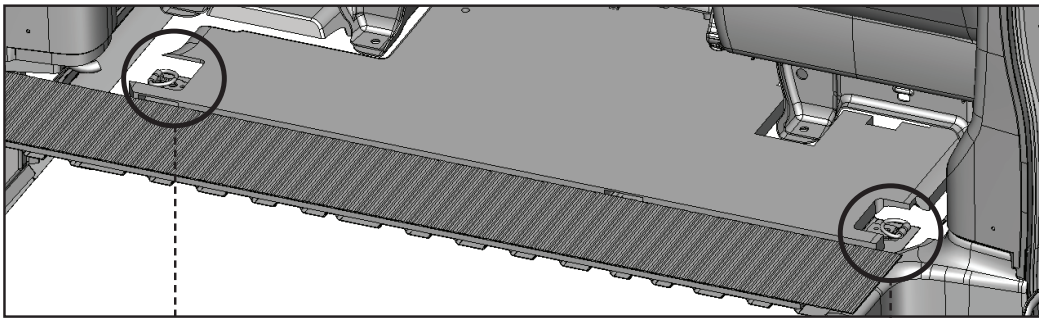

TOOLS

- Cordless Impact
- T45 Socket

2.2.2 Reinstall D-rings over floor brackets.

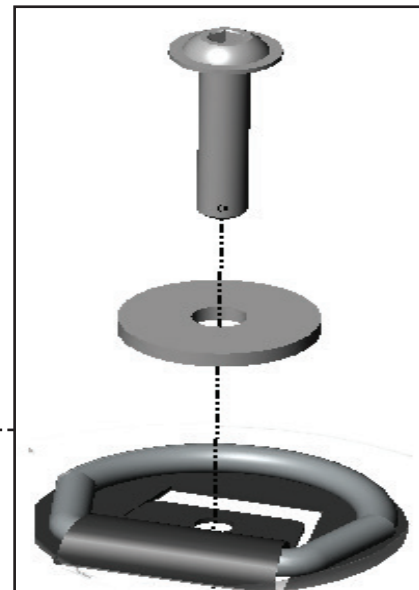
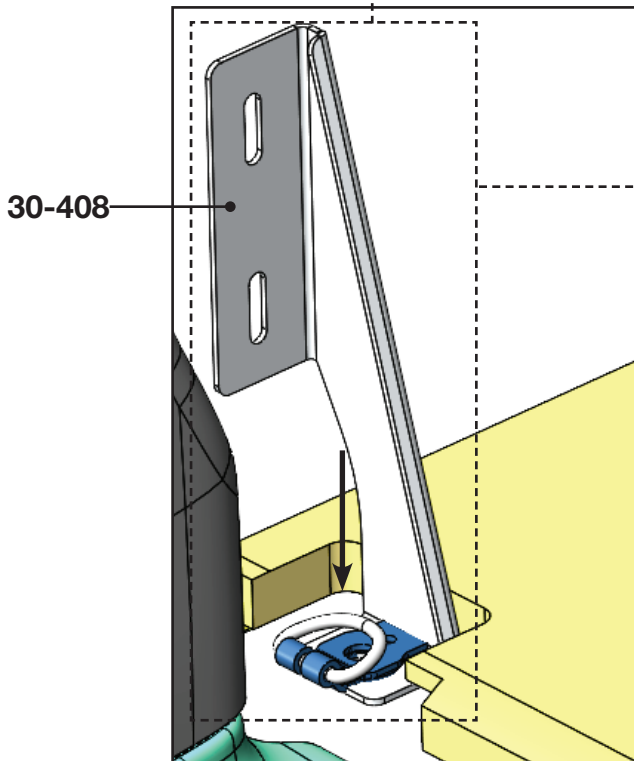
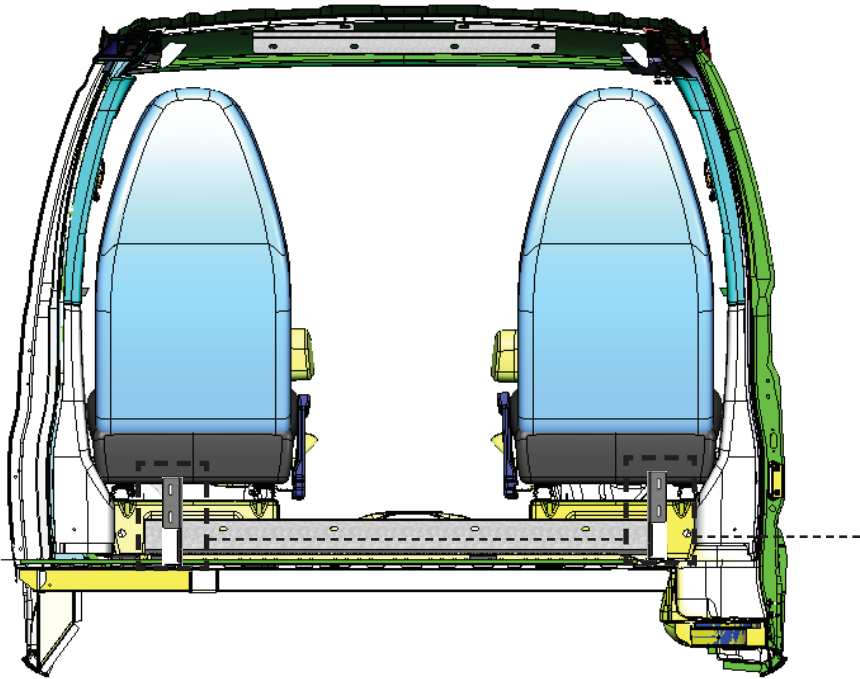

TOOLS

- Cordless Impact
- T45 Socket

PHASE 2 – INSTALLATION

2.1 TIPS ON HOW TO ATTACH A PLUSNUT

2.1.1 Attach the plusnut using the plusnut gun.

TIPS: Put the plusnut on the plusnut gun, then attach the plusnut in the hole by turning the gun forward until the plusnut locks, then remove the gun by turning in reverse.

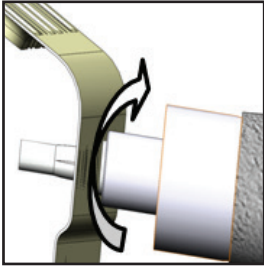

FORWARD

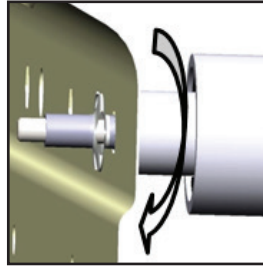

REVERSE

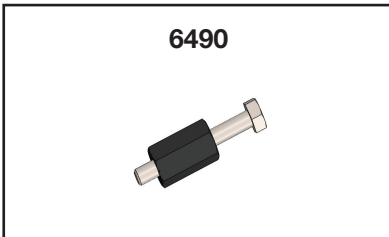

2.1.2 Attach the plusnut using the 6490 plusnut tool.

NOTE: The hardware used for the 6490 plusnut tool is not included in the fastener bag. The 6490 plusnut tool can be ordered separately upon demand at no charge.



6490

HARDWARE USED

-  Flat washer 1/4"
-  Flat washer 1/4" BS x 3/4" OD

TOOLS

- Cordless Impact
- 7/16" Socket
- 9/16" Wrench

TIPS STEP 1:

Assemble the 6490 plusnut tool with the hardware needed, plusnut and the 9/16" wrench as shown.



TIPS STEP 2:

Attach the plusnut in the hole by turning the bolt forward using an impact with a 7/16" socket until the plusnut locks, then remove the bolt by turning the impact in reverse.

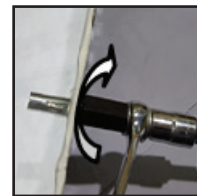

FORWARD



REVERSE

2.2.3 Install plusnuts to factory provided holes.

- Drill using a 3/8" drill bit on the factory provided holes to accommodate plusnuts.
- Attach plusnuts in the 4 holes as instructed in page 10.

TOOLS

- Plusnut Tool
- Cordless Drill
- 3/8" Drill Bit

HARDWARE USED

4x

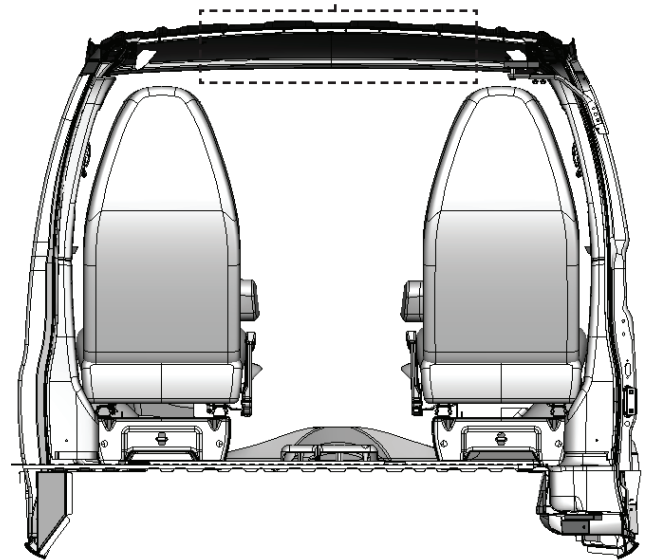
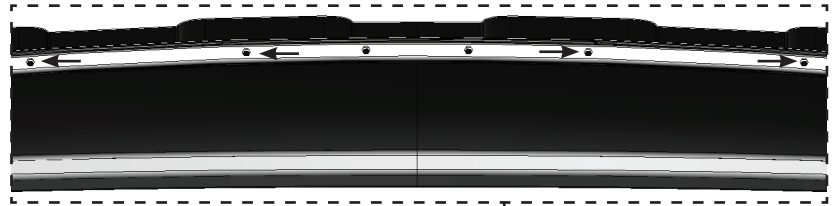
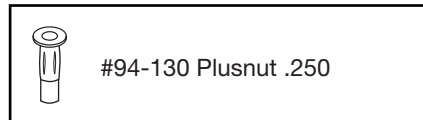

2.2.4 Install roof bracket.

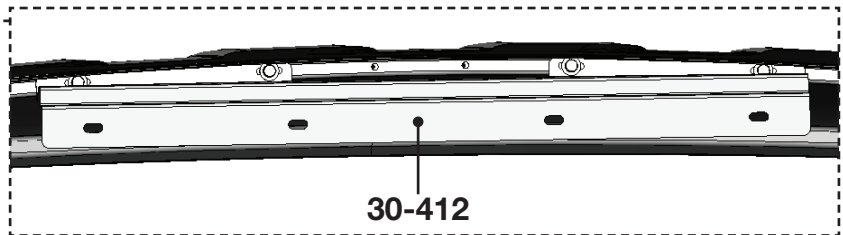
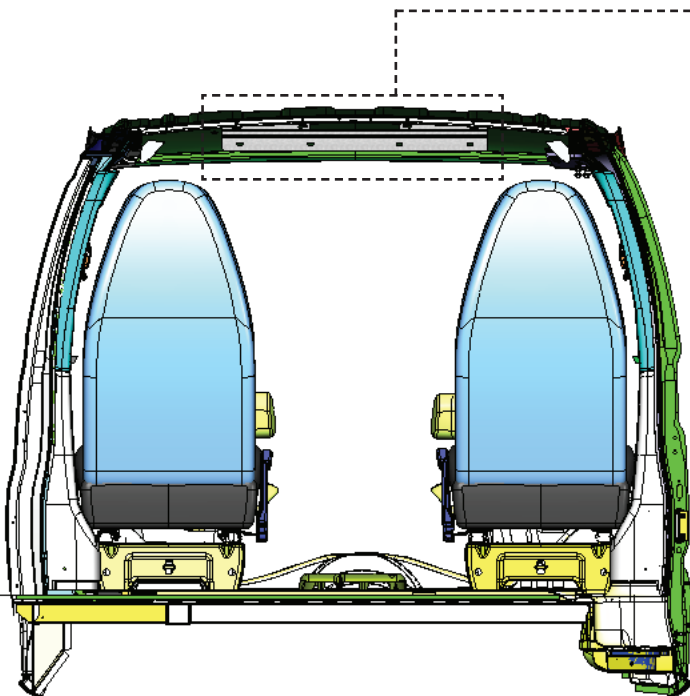

4x RECOMMENDED TORQUE SPEC: 7 LBS • FT



#90-114 Hex Bolt 1/4" x 1"



#98-118 Lock Washer



#98-110 Flat Washer

2.2.5 Install aluminum partition to roof bracket.

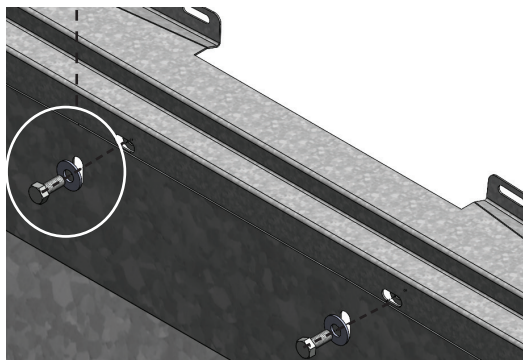
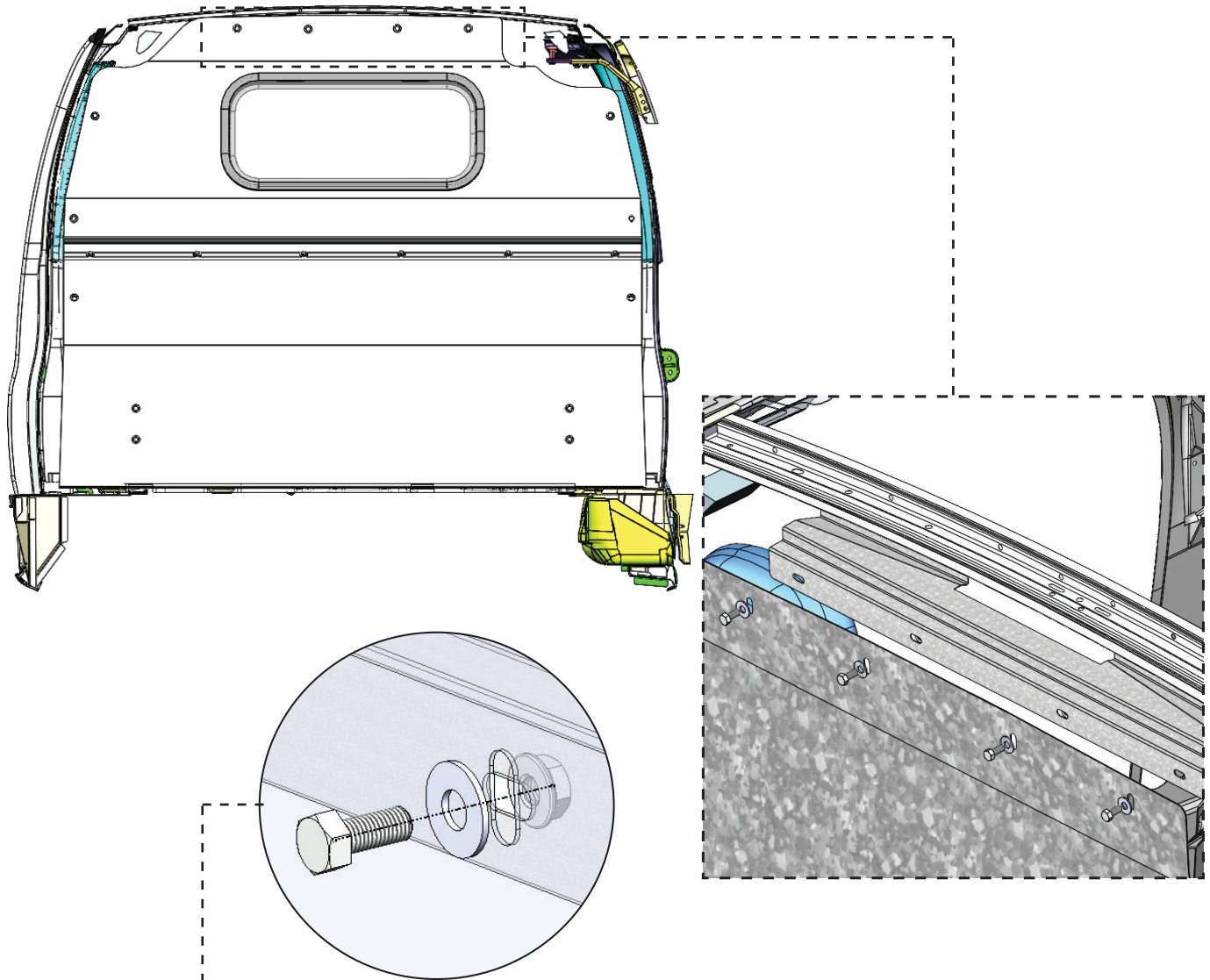



TOOLS

- Cordless Impact
- 1/2" Socket

HARDWARE USED

4x

- | | |
|---|-------------------------------|
|  | #90-204 Hex Bolt 5/16" x 3/4" |
|  | #98-116 Flat Washer |
|  | #94-116 Serrated Nut |

2.2.6 Install aluminum partition to floor bracket.

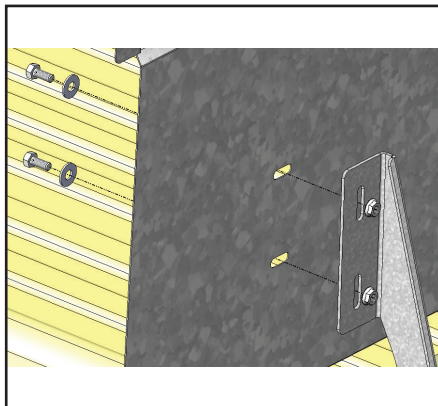
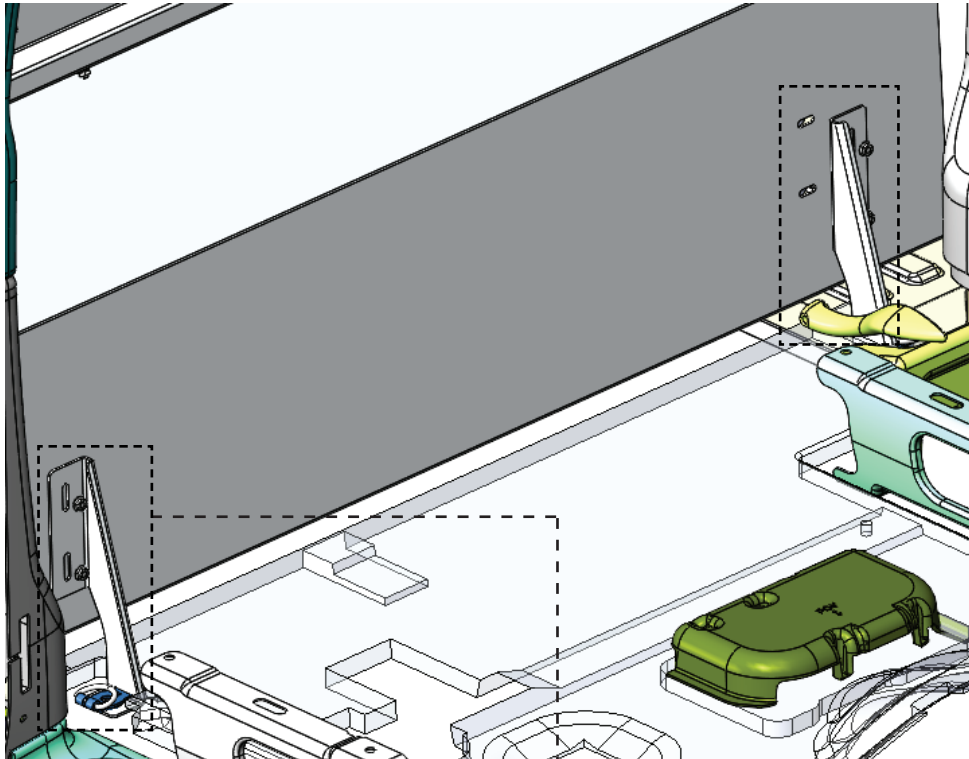



TOOLS

- Cordless Impact
- 1/2" Socket

HARDWARE

USED 4x

-  #90-204 Hex Bolt 5/16"
-  #98-116 Flat Washer
-  #94-116 Serrated Nut

2.3.3 Apply the warning label on the upper panel.

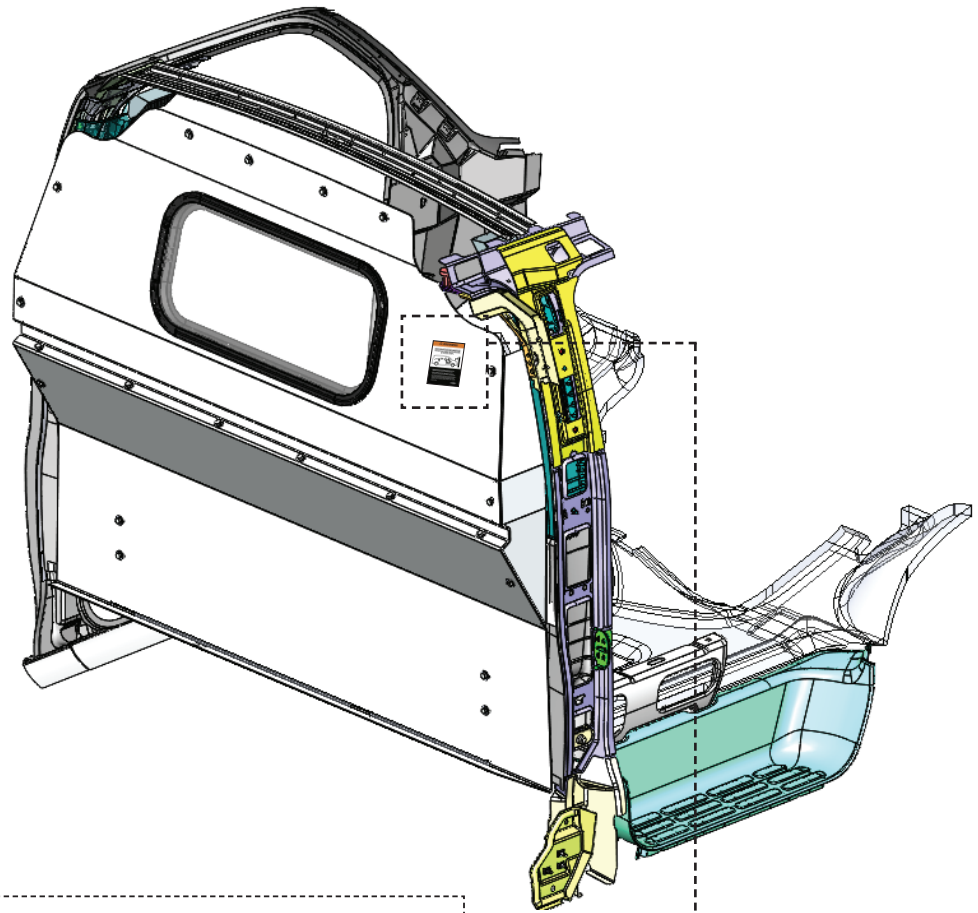

NOTE: If required, attach the Bilingual warning label to the upper panel.

“Congratulations, you have successfully installed your Contoured Partition!”

Thank you for doing business with us.”

