

# INSTALLATION GUIDE



## S3-WA48-0 WORKBENCH

Assembled On 5060-5 or 5060-6 or 5060-8  
w/ Hardwood Top ( Aluminum )



Scan the QR code for latest  
Install-Guide.



# Warnings

READ, UNDERSTAND, AND FOLLOW ALL WARNINGS AND INSTRUCTIONS BEFORE USING THIS PRODUCT. FAILURE TO FOLLOW THESE DIRECTIONS MAY RESULT IN PROPERTY DAMAGE, SERIOUS BODILY INJURY, AND/OR DEATH. RANGER DESIGN IS NOT RESPONSIBLE FOR ANY PROPERTY DAMAGE, PERSONAL INJURY, OR DEATH THAT OCCURS WHILE USING ANY RANGER DESIGN PRODUCTS. THE FINAL ALTERER AND/OR MODIFIER SHOULD REVIEW THE WARNING SHEET WITH THE CUSTOMER BEFORE THE VEHICLE IS RELEASED TO THE CUSTOMER FOR GENERAL USE. THESE INSTRUCTIONS SHOULD REMAIN WITH THE VEHICLE AT ALL TIMES.

## **WARNINGS – Prior To Starting**

- Ranger Design products must be assembled and installed by individuals qualified to use the tools required and have experience with similar products. If there is any question as to competence or experience, please contact a professional alterer or modifier.
- Failure to use Ranger Design-provided fasteners, brackets, and proper installation guidelines could increase risk of serious personal injury and/or death.
- Prior to installation, inspect the vehicle to ensure that installation will not interfere with, or cause obstruction of, any critical components such as electrical wiring, fuel tanks, fuel cells, locks, latches, etc.
- The final alterer and/or modifier is responsible for ensuring all equipment is sufficiently secured to wall and floor structures or suitable anchorages.
- Do not install systems into any weak or unsound materials such as plastics, woods, thin-walled metals, etc., without proper reinforcement.
- Do not install this product where it could interfere with the deployment of airbags. Failure to comply could result in death or serious injury.
- Do not install this product where it could ingress on the Vehicle Occupant Protection Zone. Failure to comply could result in death or serious injury.
- Incorrect installation could cause water leaks, electric shock, or fire.
- Any cargo vehicle with any cargo or equipment should use a certified partition which can be found on the Ranger Design website. (<https://rangerdesign.com>)
- Mounting rails and floors are strongly recommended for any attachment to the vehicle and can be found on the Ranger Design website. (<https://rangerdesign.com>)
- Any modification or unintended use of this product voids any warranty and could create a hazardous condition.
- Ranger Design provides recommended assembly and installation instructions which must be followed to ensure correct operation. Failure to do so could invalidate the product's compliance and/or warranty and cause injury.
- The final stage vehicle alterer and/or modifier is responsible for the integration, installation, and compliance of the product in its final location with all applicable regulations and standards. Failure to maintain compliance of the vehicle with applicable regulations and standards could be punishable by law. Alterers and/or modifiers should consult with all local authorities prior to commissioning.

- Any materials, padding, or glazing installed in the vehicle must comply with FMVSS/CMVSS 201/205/302, as applicable.

## **WARNINGS – Prior To Drilling**

- Improper drilling can cause property damage to vehicles and could lead to electric shock, fire, or even death.
- Ensure that drilling is only performed on areas of the vehicle allowed by the vehicle's Original Equipment Manufacturer's Body Builders Layout Book (or equivalent document).
- Ensure that you will not hit any critical parts of the vehicle like the gas tank, wiring harnesses, or hoses. Consult the vehicle's OEM documentation as necessary. When drilling, use a drill collar to reduce the risk of damage to the vehicle.

## **WARNINGS – Prior To Operating Vehicle**

- The heaviest items must be placed towards the bottom of the vehicle, while the lightest ones can be arranged upwards. Vehicle cargo loading weight proportion should follow the guidelines shown here.
- Check your vehicle's tare weight and remaining load capacity with all equipment installed. Never exceed the maximum Gross Vehicle Weight Rating (GVWR), Gross Axle Weight Ratings (GAWRs), or other maximum loads permitted by the vehicle's Original Equipment Manufacturer (OEM) and required by law.
- All items in the cargo area should be properly secured and partition doors closed while the vehicle is in motion.
- All system components should be regularly inspected, cleaned, and maintained pursuant to Ranger Design guidelines.

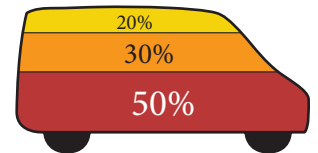

## **WARNING – In Event Of An Accident**

- In the event of a motor vehicle accident or collision where a Ranger Design system has been installed, especially ones where the vehicle's structure has been damaged and/or the air bags have deployed and/or the vehicle has been towed, the system must be inspected to ensure continued soundness and safety before returning the vehicle to service. Damaged components should be replaced as necessary.

 FR: Si vous avez besoin de ces instructions en français, s'il vous plait contacter notre service à la clientèle. +1-800-565-5321

 ES: Si necesita estas instrucciones en español, comuníquese con el Servicio de atención al cliente de Ranger Design. +1-800-565-5321

# QUICK START GUIDE

## Phase 1 - Assembly

- 1.1 Setup..... 4
- 1.2 Workbench Assembly..... 6

## Phase 2 - Installation

- 2.1 Attaching Workbench To Drawer Unit..... 9
- 2.2 Attach Wall Brackets To The End Panels..... 11
- 2.3 Mark Holes For Plus Nuts..... 12
- 2.4 Attach Plus Nut..... 13
- 2.5 Attach Shelf Unit To the Floor..... 15
- 2.6 Attach Wall Brackets..... 18

# REQUIRED ITEMS

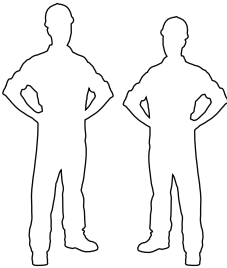

**2  
PERSONS**

- Cordless Impact
- Cordless Drill
- Tape Measure
- Marker
- 1/2" Socket
- 1/2" Drill Bit w/ Drill Collar ( Set at 1/2" )
- 3/16" Drill Bit
- 3/8" Driver Bit
- Knife
- Plusnut Tool / Plusnut Gun ( 5/16" )

# PHASE 1 – ASSEMBLY

## 1.1 SETUP

1.1.1 Unpack components; compare with the bill of materials.

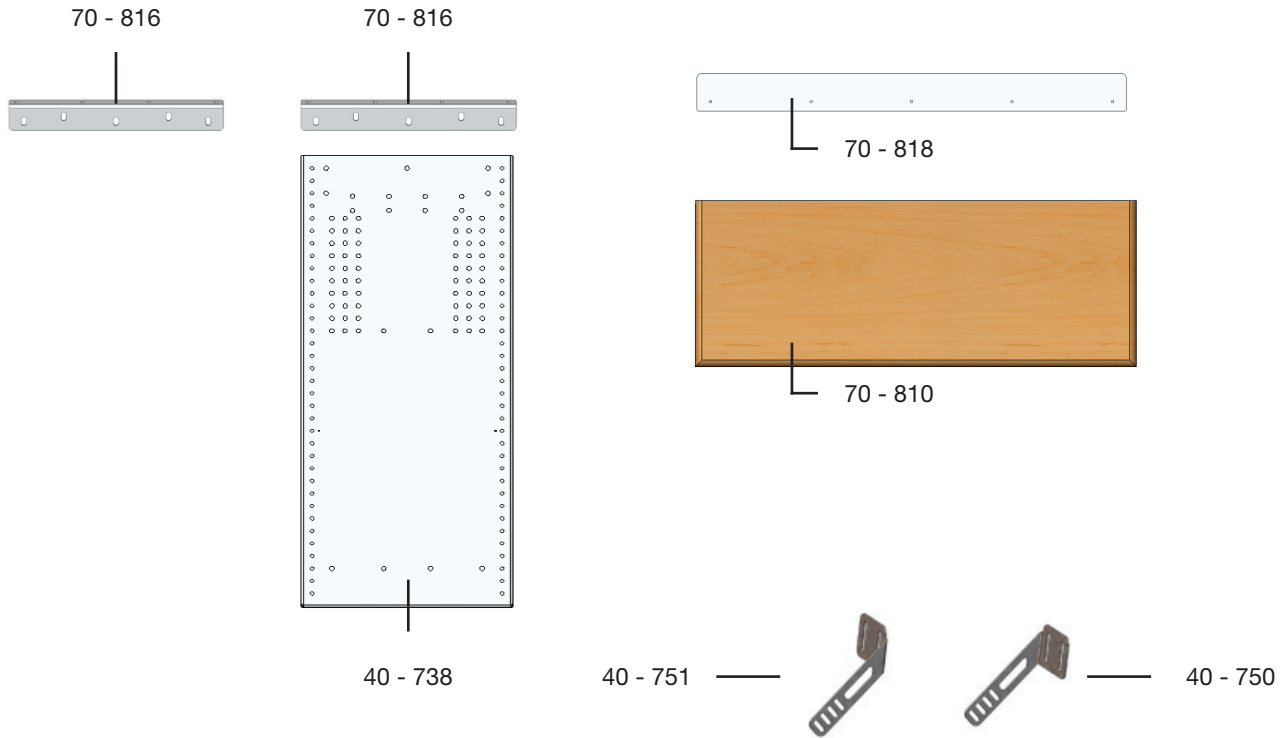

1.1.2 Verify all parts are present.

### BILL OF MATERIALS

Item No.	Description	Qty.
40-750	Bracket, N5 series, Right	1
40-751	Bracket, N5 series, Left	1
40-738	End - Panel	1
70-810	Hardwood Top	1
70-816	Side Panel Bracket	2
70-818	Straight Backsplash	1
96-4804	Install Fastener Kit	1
94-4803	Assembly Fastener Kit	1

1.1.3 Fastener kits.

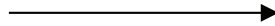

96 - 4804 Fastener Kit



Fastener Assembly

- 2x  # 90-011 Hex Bolt  
5/16"-18 x 1-3/4"  
ZINC
- 2x  # 90-204 Hex Bolt  
5/16"-18 x 3/4"  
ZINC
- 2x  # 90-212 Hex Bolt  
5/16"-18 x 1-1/4"  
ZINC
- 2x  # 94-116 Serrated Nut  
5/16"-18  
ZINC
- 4x  # 94-132 Plusnut 5/16"
- 6x  # 98-116 Flat Washer  
5/16", O.D. 7/8"  
ZINC
- 4x  # 98-122 Lock Washer  
5/16"  
ZINC
- 2x  # 98-157 Spacer  
0.375" ID, x 1.0" OD x 0.25" LONG  
NYLON





2x

 #90-204 Hex Bolt 5/16" x 3/4"  
 #98-116 Flat Washer  
 #94-116 Serrated Nut

2x

 #90-212 Hex Bolt 5/16" x 1-1/4"  
 #98-122 Lock Washer  
 #98-116 Flat Washer  
 #94-132 5/16" Plusnut

2x

 #90-011 Hex Bolt 5/16" x 1-3/4"  
 #98-122 Lock Washer  
 #98-116 Flat Washer  
 #98-157 Spacers  
( QTY = GAP BETWEEN FLOOR AND END PANEL )  
 #94-132 5/16" Plusnut

## 94-4803 Fastener Kit



## Fastener Assembly

3x



# 90-204

Hex Bolt  
5/16"-18 x 3/4"  
ZINC

13x



# 92-102

Screw HWH  
#14 x 1"  
ZINC

3x



# 94-116

Serrated Nut  
5/16"-18  
ZINC

3x



# 98-116

Flat Washer  
5/16" - 18 x 1"  
ZINC

3x



#90-204 Hex Bolt 5/16" x 3/4"



#98-116 Flat Washer



#94-116 Serrated Nut

13x



#92-102 Screw #14 x 1"

# PHASE 1 – ASSEMBLY

## 1.2 WORKBENCH ASSEMBLY

1.2.1 Attach side panels bracket to the end panel.

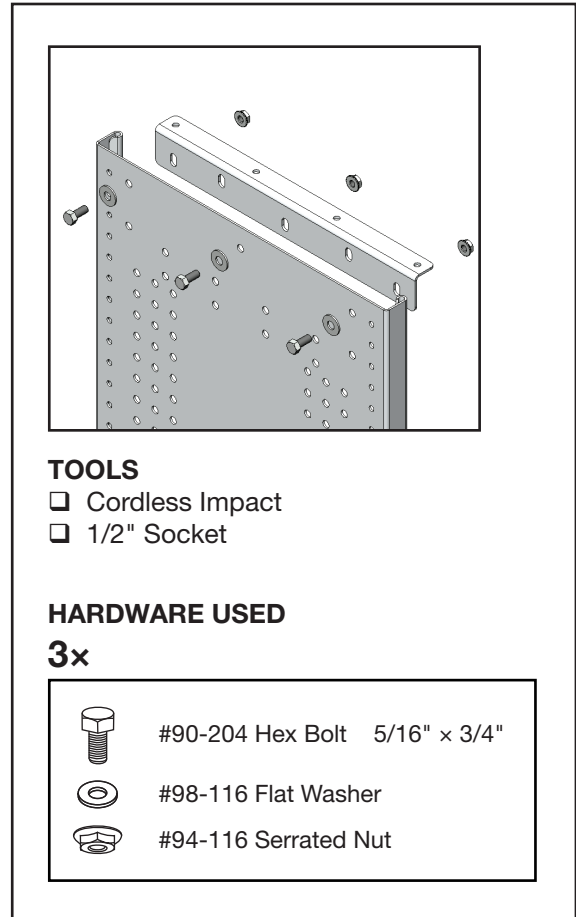
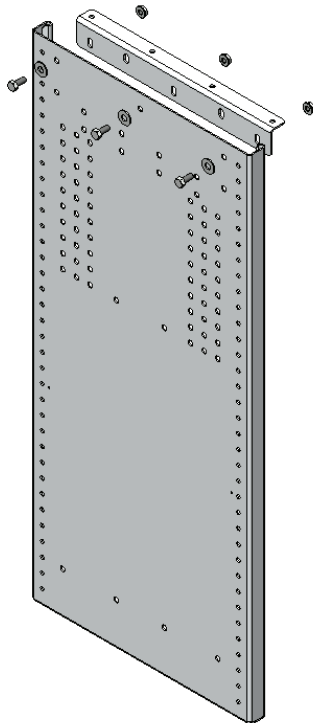

**1.2.2** Screw the hardwood top on the side panel bracket with the back of the hardwood top flushed against one end of the panels.

**NOTE:** Pre-drill the hardwood using 3/16" drill bit first before screwing the bracket to the hardwood to prevent splitting the wood.

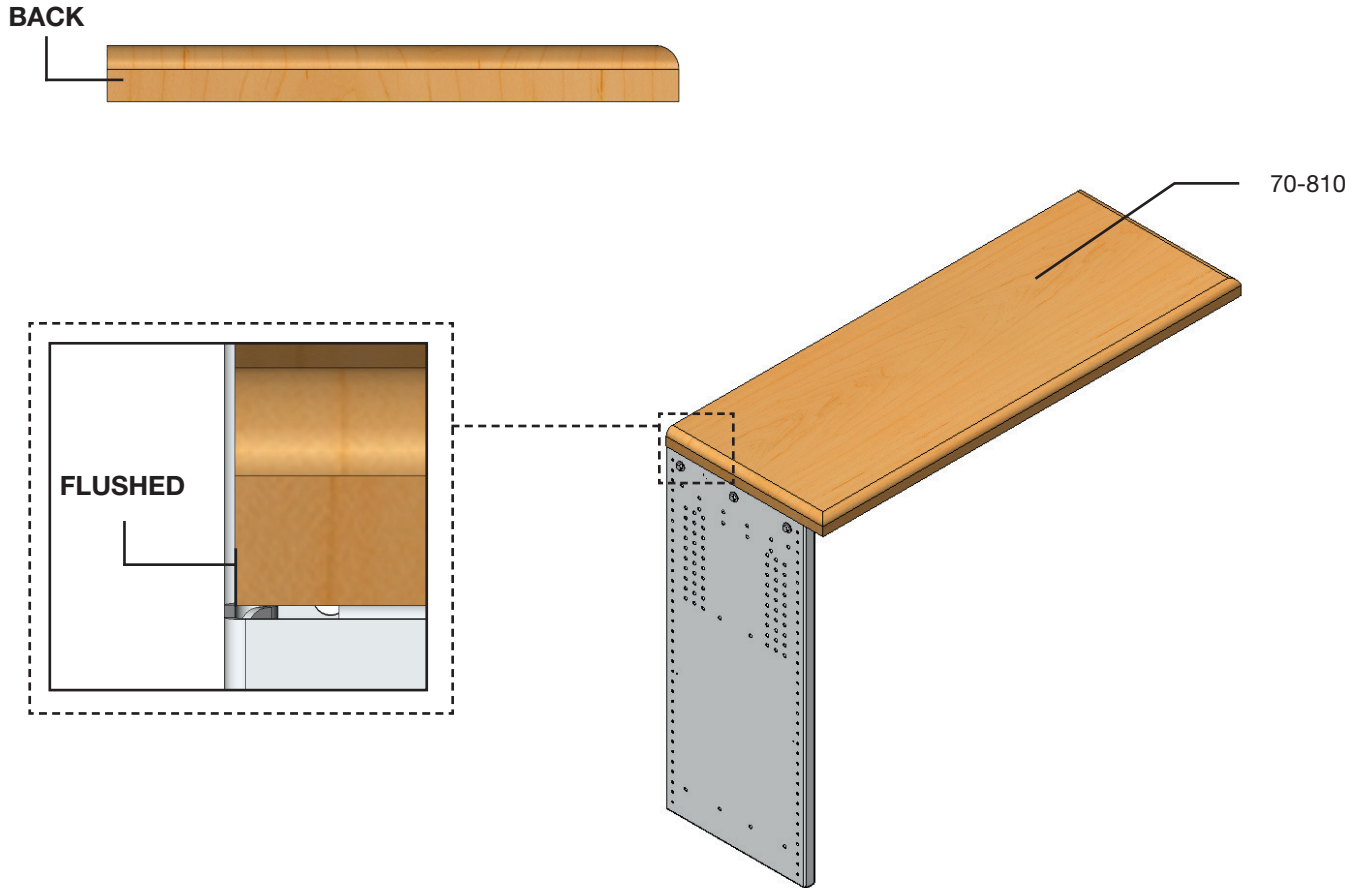

**NOTE:** Use slots to avoid screwing into the splits in the hardwood top.

**TOOLS**

- Cordless Impact
- Cordless Drill
- 3/8" Driver Bit
- 3/16" Drill Bit

**HARDWARE USED**

**4x**

#92-102 Screw #14 x 1"

**1.2.3** Screw the backsplash on the back end of the workbench.

**NOTE:** Pre-drill the hardwood using 1/8" drill bit first before screwing the backsplash to the hardwood to prevent splitting the wood.

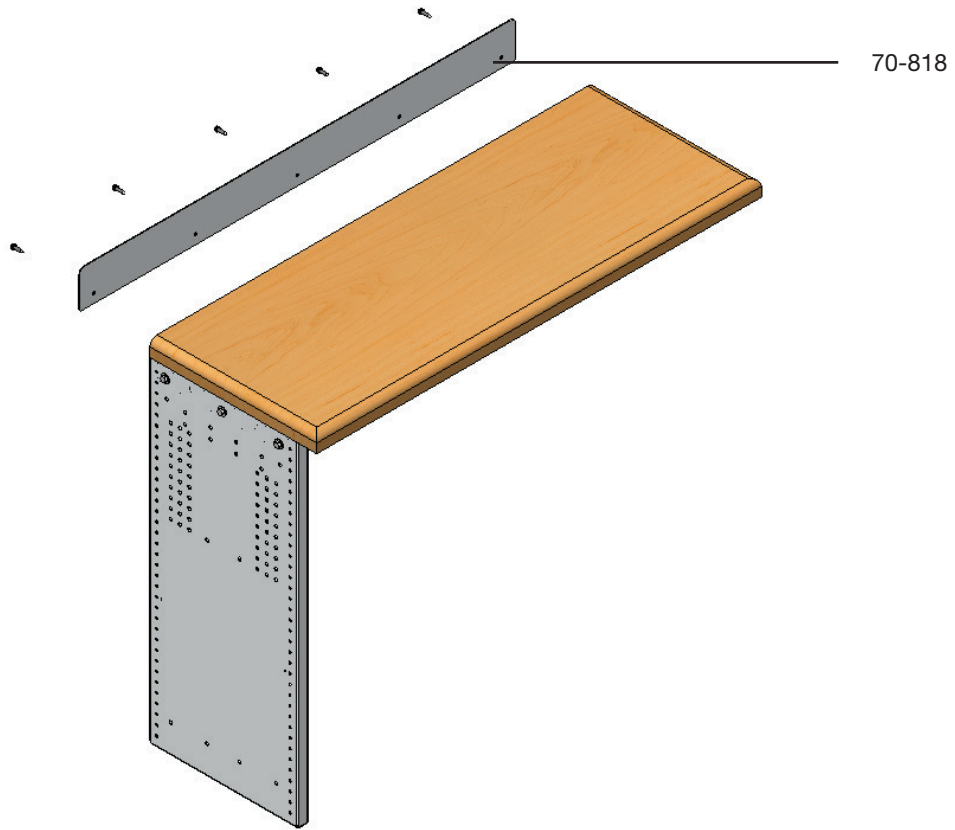

This close-up diagram shows a metal screw being inserted into a hole in the metal backsplash strip, which is being attached to the wooden workbench top. The workbench top is supported by a metal frame.

**TOOLS**

- Cordless Impact
- Cordless Drill
- 3/8" Driver Bit
- 3/16" Drill Bit

**HARDWARE USED**

**5x**

	#92-102 Screw #14 x 1"
---	------------------------

# PHASE 2 – INSTALLATION

## 2.1 ATTACHING WORKBENCH TO DRAWER UNIT

2.1.1 Remove the top drawer of the installed drawer unit, then attach the side panel bracket to the side panel of the drawer unit.

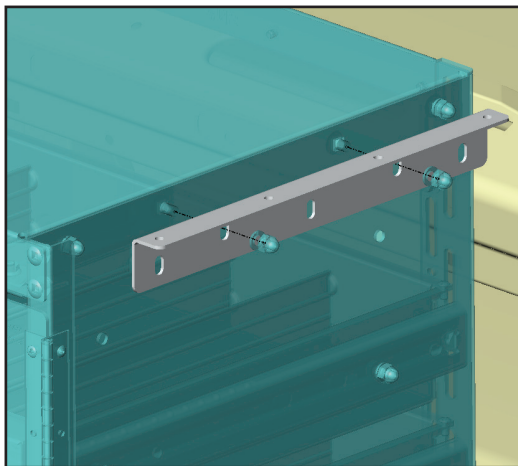
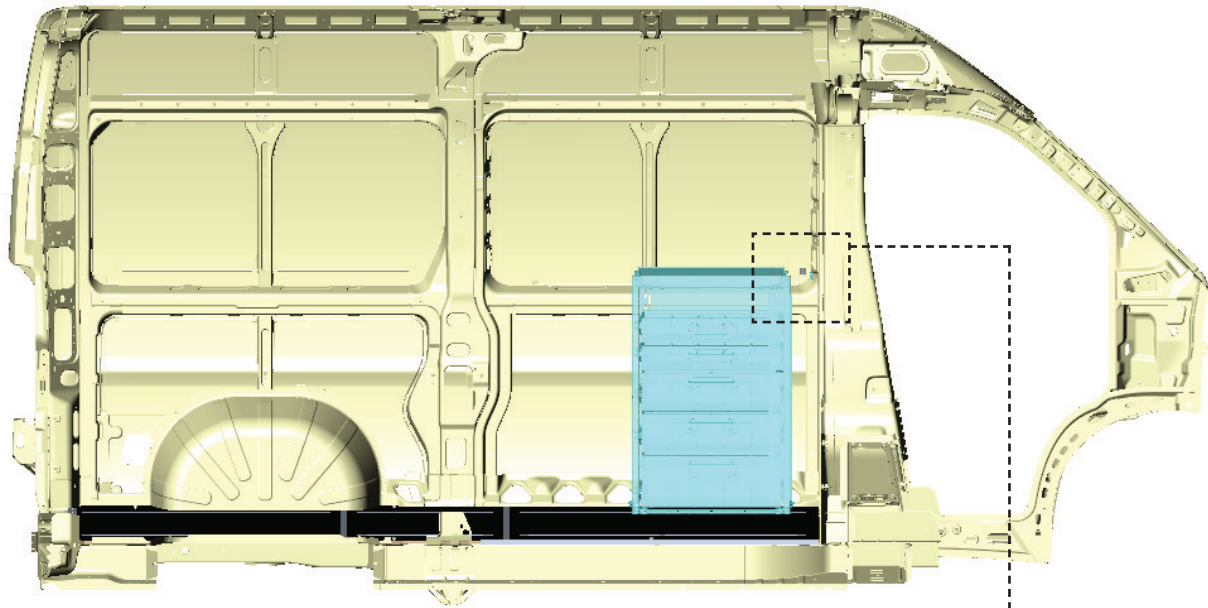

### TOOLS

- ☐ Cordless Impact
- ☐ 1/2" Socket

### HARDWARE USED

**2x** DRAWER HARDWARE



Carriage Bolt 1/2" & 5/8"

Lock Washer 5/16"

Acorn Nut 5/16"

- 2.1.2** • Lift the assembled workbench to the vehicle, then put it in place.  
 • Attach the side panel bracket to the hardwood top, then slide the top drawer back.

**NOTE:** Pre-drill the hardwood using 1/8" drill bit first before screwing the bracket to the hardwood to prevent splitting the wood.

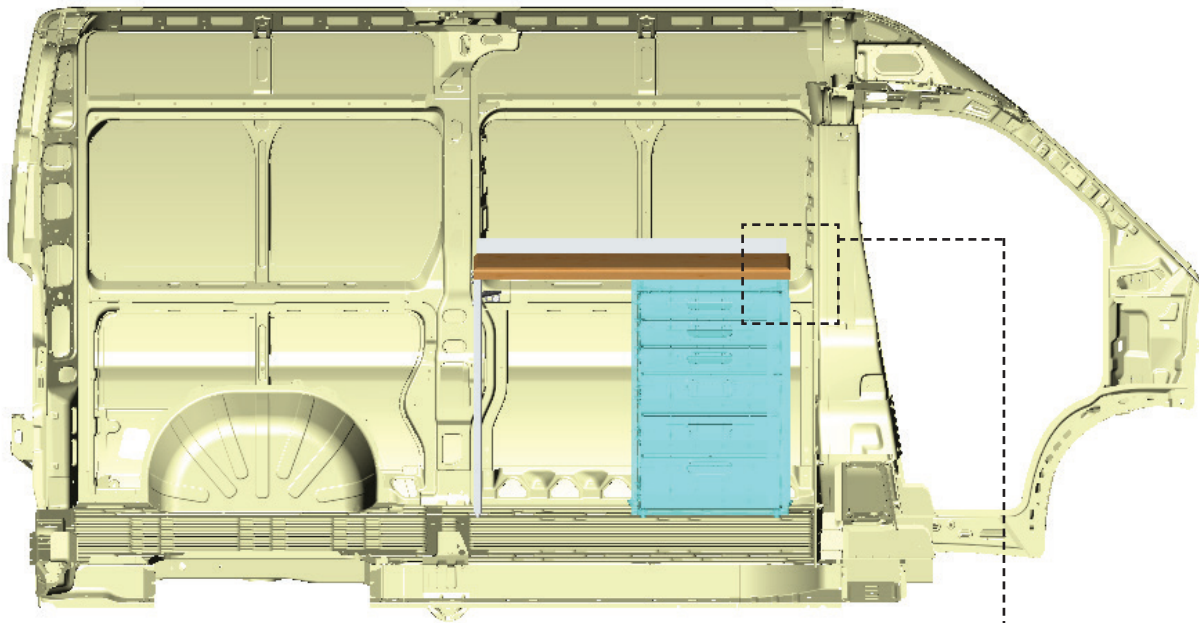

**TOOLS**

- Cordless Impact
- Cordless Drill
- 3/8" Driver Bit
- 3/16" Drill Bit

**HARDWARE USED**

**4x**

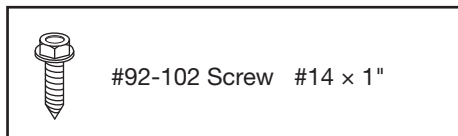

# PHASE 2 – INSTALLATION

## 2.2 ATTACH WALL BRACKETS TO THE END PANELS

2.2.1 Attach the wall bracket to the panels aligning the bracket to the horizontal rim of the vehicle.

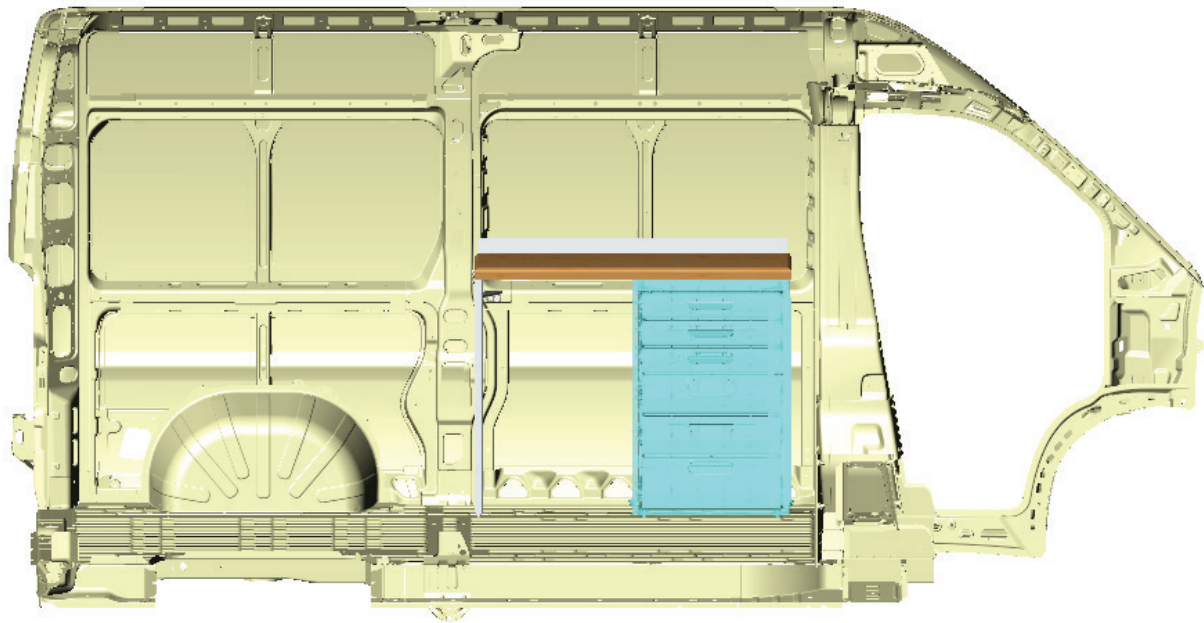



**TOOLS**

- Cordless Impact
- 1/2" Socket

**HARDWARE USED**

**2x** HAND-TIGHTEN THE BOLTS

	#90-204 Hex Bolt 5/16" x 3/4"
	#98-116 Flat Washer
	#94-116 Serrated Nut

# PHASE 2 – INSTALLATION

## 2.3 MARK HOLES FOR PLUS NUTS

2.3.1 After attaching the brackets, mark the holes from the brackets and bottom shelf to the vehicle.

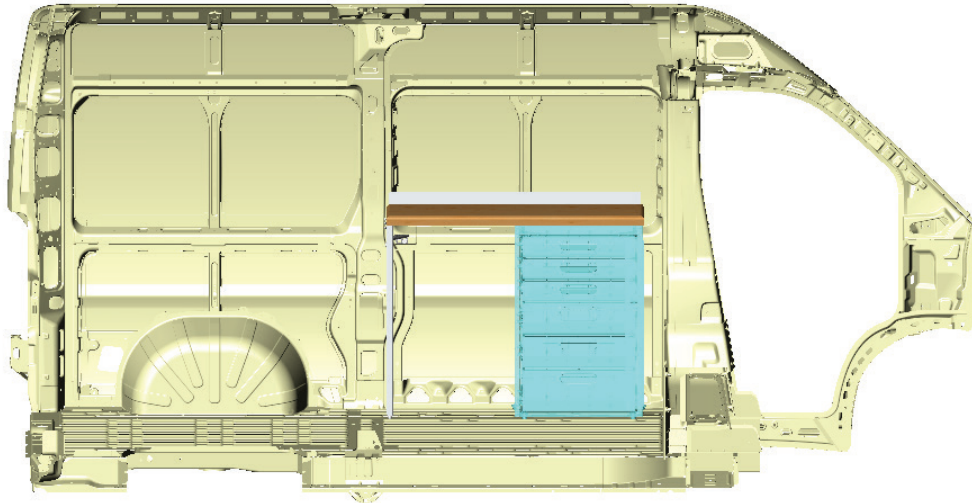

Mark 2 holes of the brackets head on the vehicle horizontal rim.

**NOTE:** If you are using Ranger wall kit, please go to **PAGE 18**.

**TOOLS**

- Marker

MARK

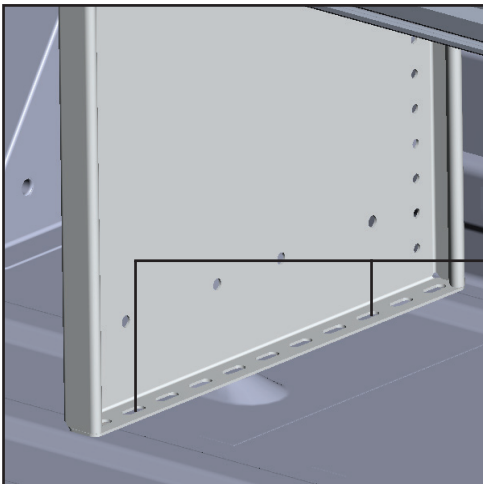
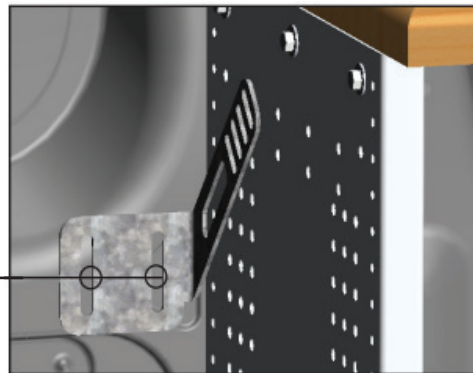

Mark 2 holes of each end panel on the vehicle floor.

**NOTE:** If you are using Ranger floor, please go to **PAGE 16 OR 17**.

**TOOLS**

- Marker

MARK

# PHASE 2 – INSTALLATION

## 2.4 ATTACH PLUS NUTS

- 2.4.1 • Remove the workbench side panel.  
• Drill all the marks using 1/2" drill bit w/ drill collar, then attach plus nuts to the holes.

**NOTE:** Use 1/2" drill bit with drill collar to stop drill at 1/2" depth.

**WARNING:** Before drilling, ensure that you will not hit any critical parts of the vehicle like the **Gas tank, Wiring Harness and Hose.**

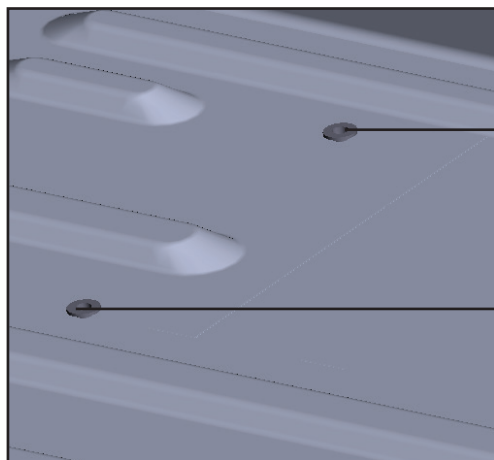
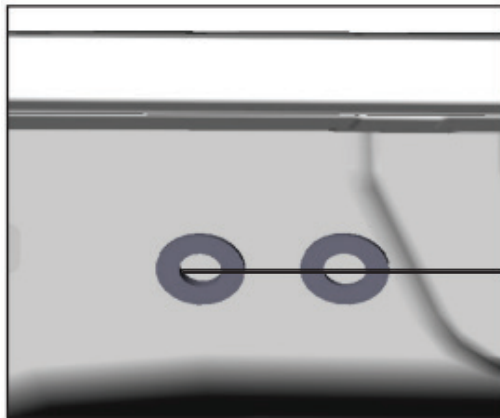
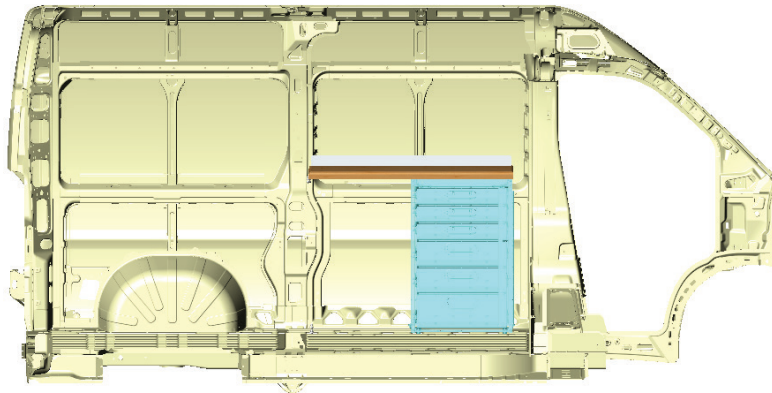

### PLUSNUT

Drill all the marks then, attach plus nuts to the holes.

### TOOLS

- Cordless Drill
- 1/2" Socket
- 1/2" Drill Bit w/ Drill Collar ( Set at 1/2" )
- Plus Nut Tool ( 5/16" )

### HARDWARE USED

4x



#94-132 Plus Nut



DRILL COLLAR  
( SET AT 1/2" )

## 2.4.2 How to attach plus nut.

### • USING PLUSNUT GUN

**STEP:** Put the plusnut on the plusnut gun, then attach the plus nut in the hole by turning the gun forward until the plus nut locks, then remove the gun by turning in reverse.

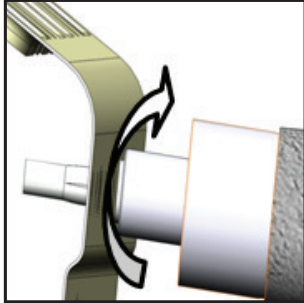

**FORWARD**

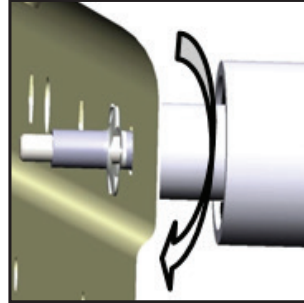



**REVERSE**

### • USING THE 6491 PLUSNUT TOOL

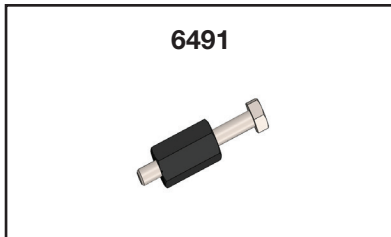
**NOTE:** The hardware used for the 6490 plusnut tool is not included in the fastener bag.  
The 6491 plusnut tool can be ordered separately upon demand at no charge.



#### HARDWARE USED

-  Flat washer 5/16"
-  Flat washer 5/16" BS x 7/8" OD

#### TOOLS

- Cordless Impact
- 1/2" Socket
- 9/16" Wrench

#### STEP 1:

Assemble the 6491 plusnut tool with the hardware needed, plus nut and the 9/16" wrench as shown.



#### STEP 2:

Attach the plus nut in the hole by turning the bolt forward using an impact with a 1/2" socket until the plusnut locks, then remove the bolt by turning the impact in reverse.

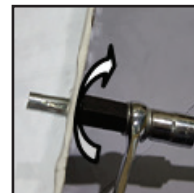

**FORWARD**



**REVERSE**

# PHASE 2 – INSTALLATION

## 2.5 ATTACH SHELF UNIT TO THE FLOOR

### WITHOUT RANGER FLOOR

2.5.1 Reinstall the workbench side panel to the side panel bracket, then attach the bottom of the workbench side panel to the plusnut.

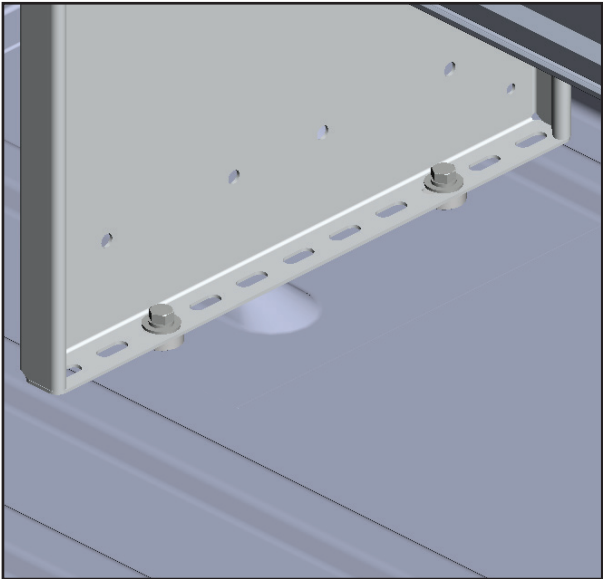
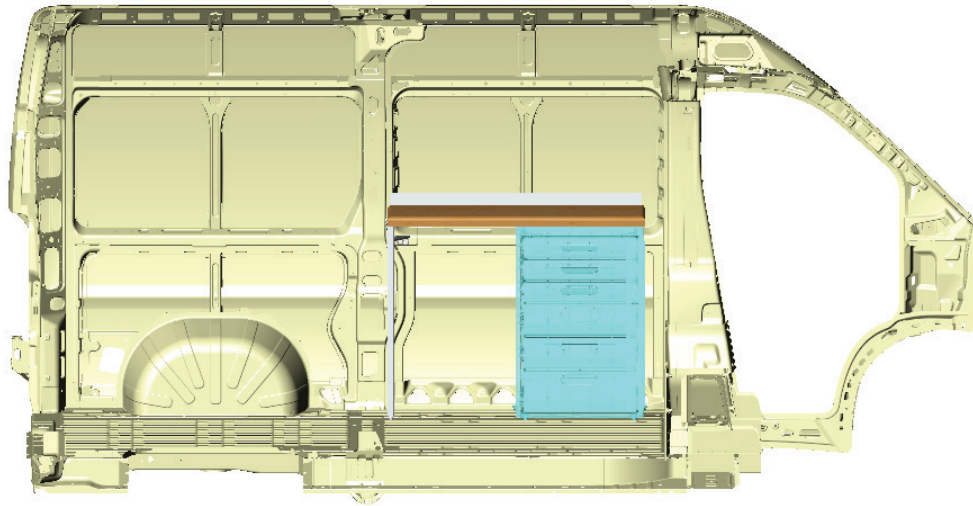





**TOOLS**

- Cordless Impact
- 1/2" Socket

**HARDWARE USED**

**2x**

	#90-011 Hex Bolt 5/16" x 1-3/4"
	#98-122 Lock Washer
	#98-116 Flat Washer
	#98-157 Spacers ( QTY = GAP BETWEEN FLOOR AND END PANEL )
	#94-132 5/16" Plusnut

**TIPS WHEN TO USE SPACER:**  
MOST VEHICLES USE 1 SPACER WHEN NOT INSTALLING OVER RIBS.

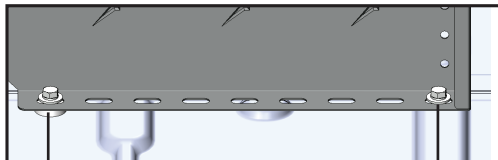

W/ Spacer

W/O Spacer

## WITH RANGER 6541 SERIES FLOOR

2.5.2 Reinstall the workbench side panel to the side panel bracket. Then attach the bottom of the workbench side panel to the floor.

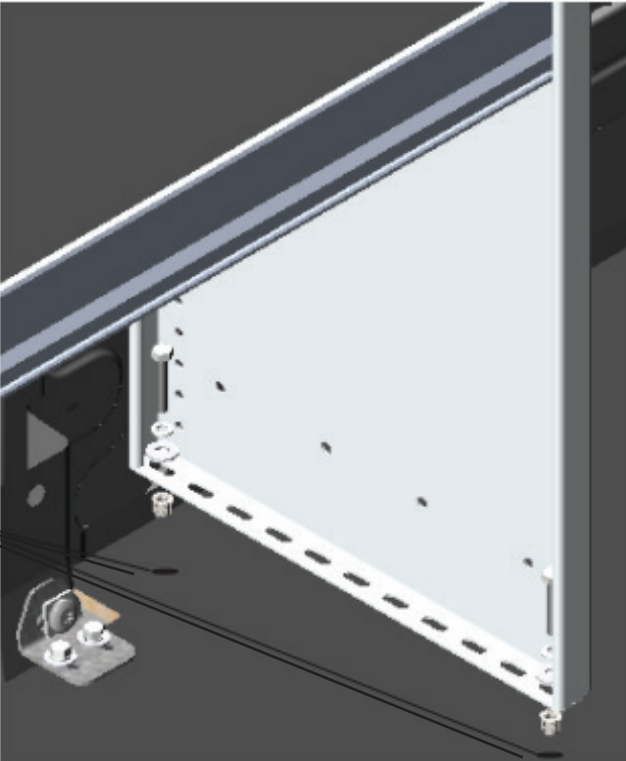
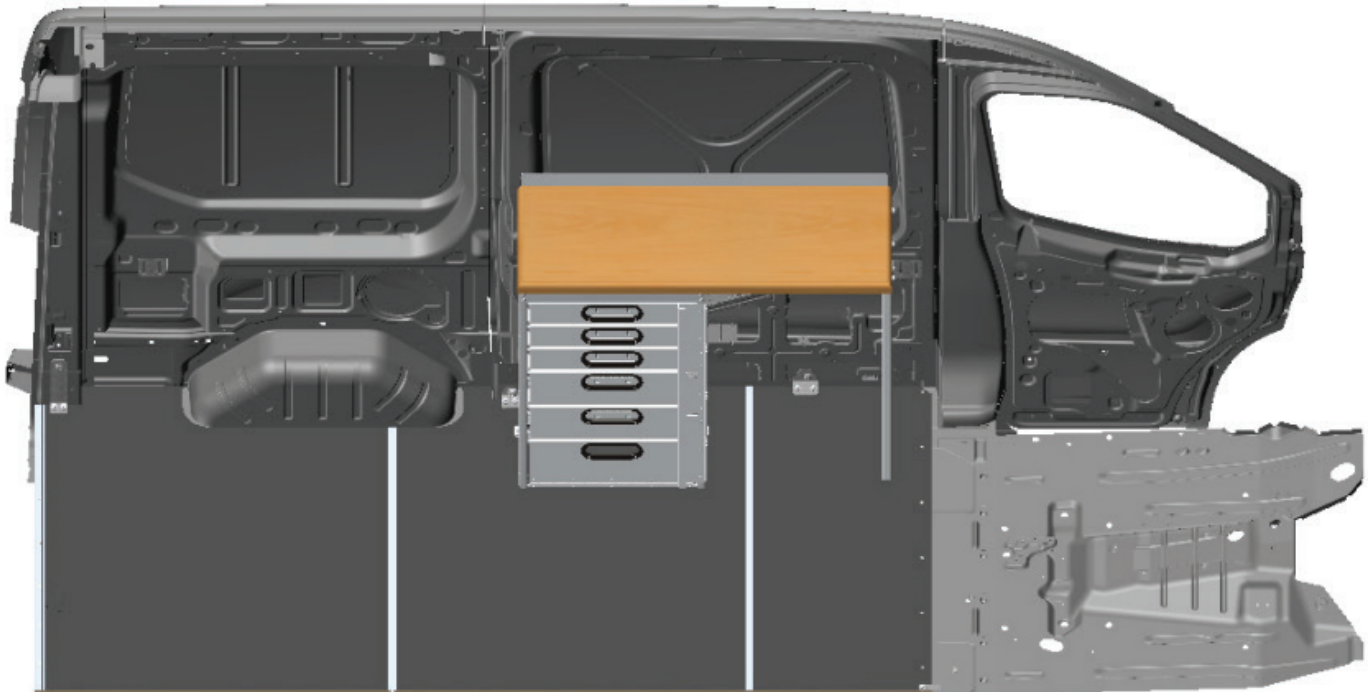





**TOOLS**

- Cordless Impact
- 1/2" Socket

**HARDWARE USED**

**2x** FLOOR FASTENER KIT

	#90-204 Hex Bolt 5/16" x 3/4"
	#98-122 Lock Washer
	#98-116 Flat Washer
	#99-114 Zinc Alloy Tapping Inserts for Softwood

## WITH RANGER 6540 SERIES FLOOR

**2.5.3** Reinstall the workbench side panel to the side panel bracket. Then attach the bottom of the workbench side panel to the floor.

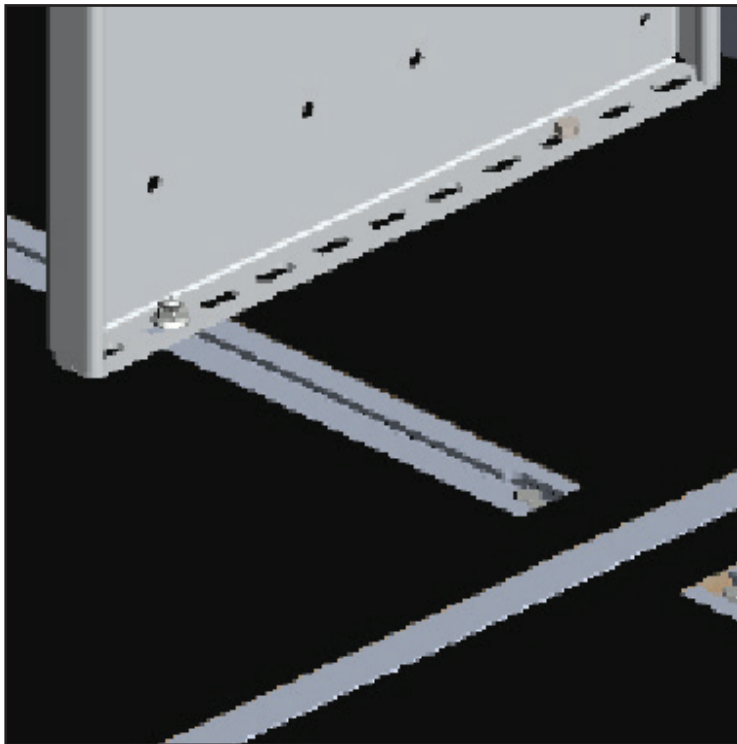
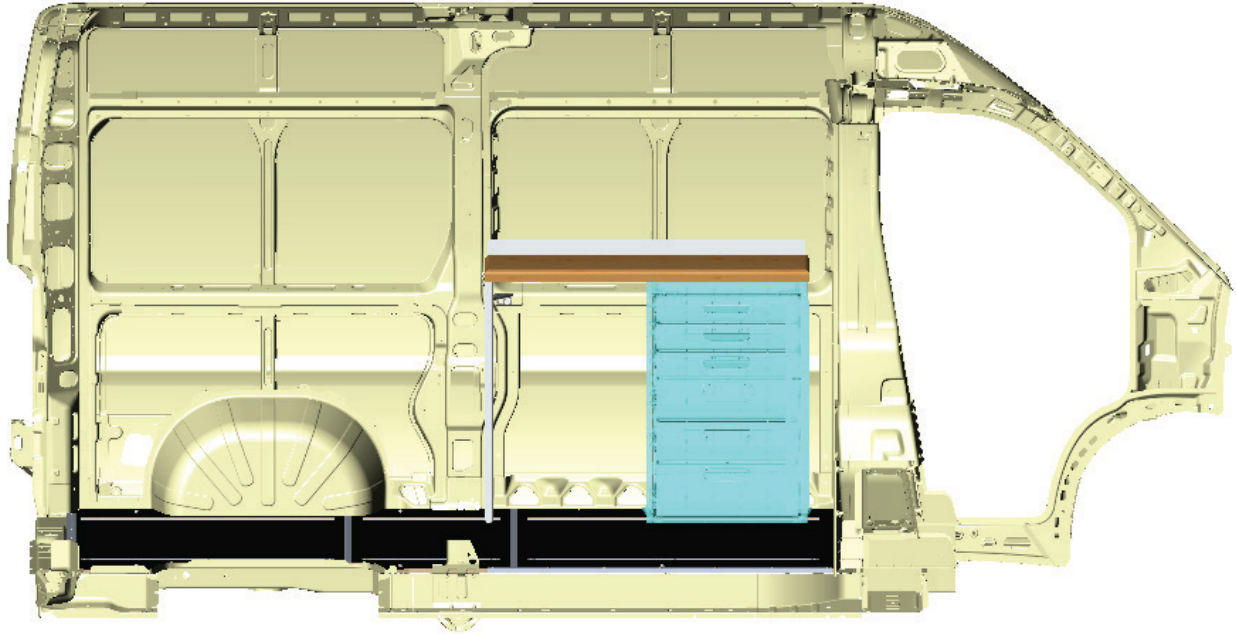

### TOOLS

- Cordless Impact
- 3/8" Driver Bit
- 1/2" Socket

### HARDWARE USED

**1x** FLOOR FASTENER KIT



#92-102 Screw 1"

### HARDWARE USED

**1x** FLOOR FASTENER KIT



#94-104 Hex Nut



#98-122 Lock Washer



#98-116 Flat Washer



#90-490 Carriage Bolt 5/16" x 1"

# PHASE 2 – INSTALLATION

## 2.6 ATTACH WALL BRACKETS

### WITHOUT RANGER WALL KITS

2.6.1 Align the wall brackets to the plus nuts, then install the wall brackets to the wall.

**NOTE:** Tighten the bolts that attach the bracket to the wall or wall rails 1<sup>st</sup> before tightening the bolts from the brackets to the end panels.

**IMPORTANT:** After installation is completed, ensure all bolts are tightened.

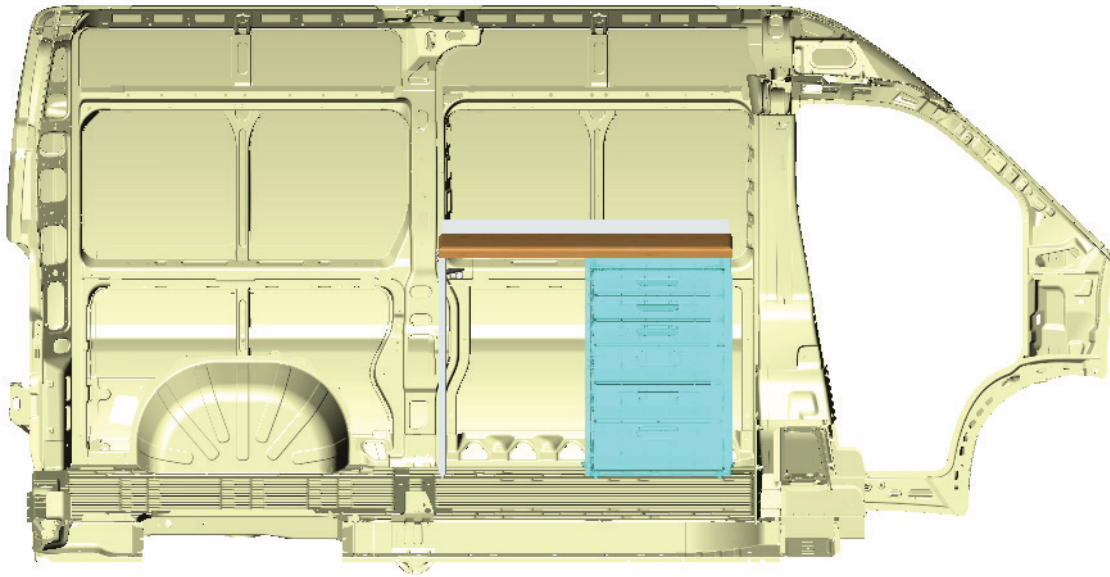

#### TOOLS

- Cordless Impact
- 1/2" Socket

#### HARDWARE USED

2x



#90-212 Hex Bolt 5/16" x 1-1/4"

#98-122 Lock Washer

#98-116 Flat Washer

#94-132 5/16" Plusnut

## WITH RANGER WALL KITS

**2.6.2** Align the wall brackets to the wall mounting track kits, then install the wall brackets to the wall mounting track kits using channel nuts.

**NOTE:** Tighten the bolts that attach the bracket to the wall or wall rails 1<sup>st</sup> before tightening the bolts from the brackets to the end panels.

**IMPORTANT:** After installation is completed, ensure all bolts are tightened.

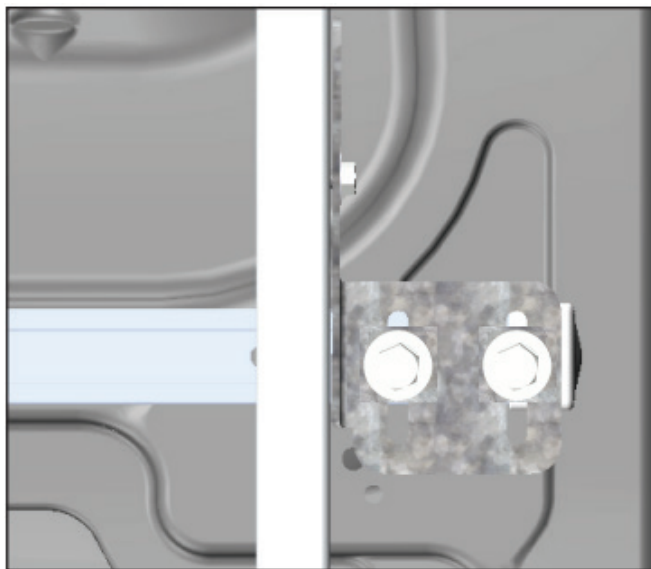
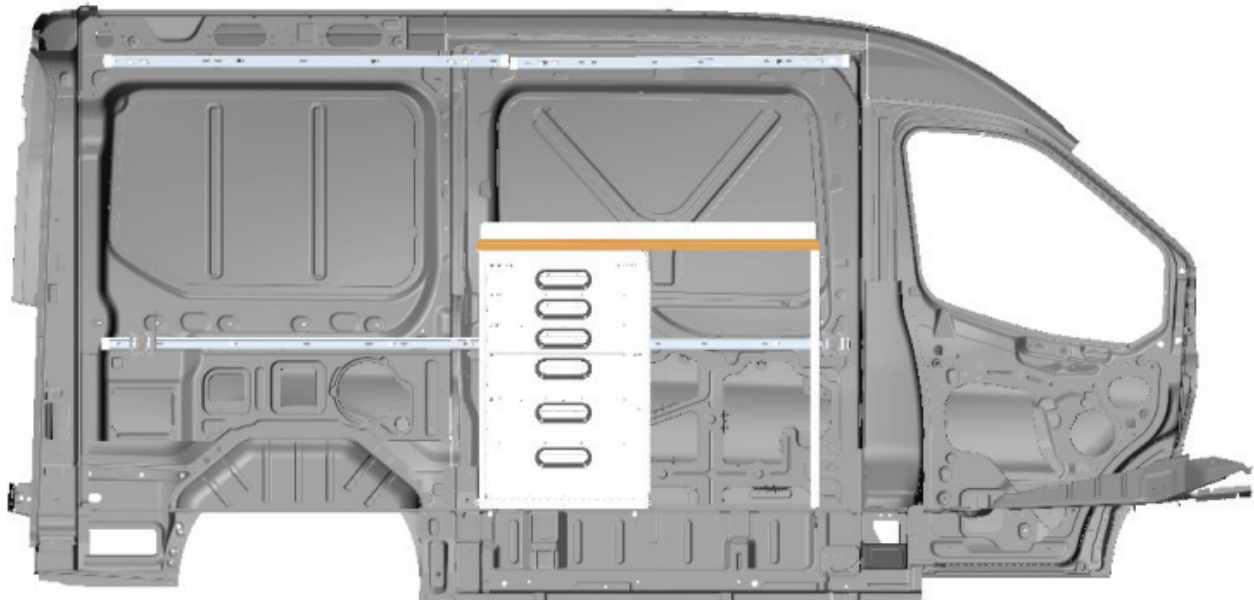

### TOOLS

- Cordless Impact
- 1/2" Socket

### FASTENERS USED

**2x** WALL KITS FASTENER KIT



#90-208 Hex Bolt 5/16" × 1"



#98-122 Lock Washer



#98-116 Flat Washer



#94-150 Channel Nut

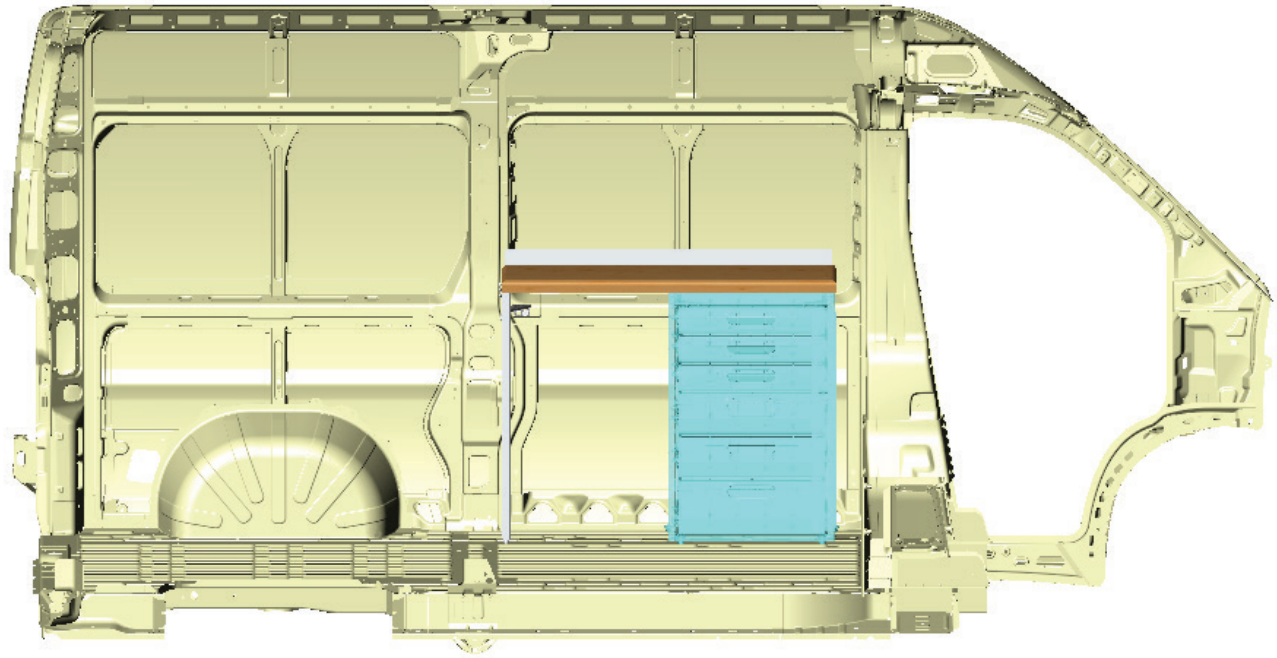

**“You have successfully installed your  
Workbench**

**Thank you for doing business with us.”**

For any feedback or suggestions you may have, please contact: [cs@rangerdesign.com](mailto:cs@rangerdesign.com)

