

INSTALLATION GUIDE



1506-PHX CARGO + RAM ProMaster 159" EXT Wheelbase



Scan the QR for the latest Install-Guide.





BEFORE YOU BEGIN

READ, UNDERSTAND, AND FOLLOW ALL WARNINGS AND INSTRUCTIONS BEFORE USING THIS PRODUCT. FAILURE TO FOLLOW THESE DIRECTIONS MAY RESULT IN PROPERTY DAMAGE, SERIOUS BODILY INJURY, AND/OR DEATH. RANGER DESIGN IS NOT RESPONSIBLE FOR ANY PROPERTY DAMAGE, PERSONAL INJURY, OR DEATH THAT OCCURRED WHILE USING ANY RANGER DESIGN PRODUCTS.



WARNING

- Failure to use Ranger Design-provided fasteners, brackets, and proper installation guidelines could increase risk of serious personal injury and/or death.
- If drilling is required to complete this installation: improper drilling can cause property damage to vehicles and could lead to electric shock, fire, or even death.
- If drilling is required to complete this installation: Ensure that drilling is only performed on areas of the vehicle allowed by the vehicle's Original Equipment Manufacturer's Body Builders Layout Book (or equivalent document).
- Prior to installation, inspect the vehicle to ensure that installation will not interfere with, or cause obstruction of, any critical components such as electrical wiring, fuel tanks, fuel-cells, locks, latches, etc.
- The installer or manufacturer is responsible for ensuring anchorages are installed onto suitable wall and floor structures; wall and floor strength must meet applicable performance requirements.
- Do not install systems into any weak or unsound materials such as plastics, woods, thin-walled metals, etc. without proper reinforcement.
- Do not install this product where it could interfere with the deployment of airbags. Failure to comply could result in death or serious injury.
- Do not install this product where it could ingress on the Transit Occupant Protection Zone. Failure to comply could result in death or serious injury.
- Incorrect installation could cause water leaks, electric shock or fire.
- Any cargo vehicle with any cargo or equipment should use a certified partition. See Ranger Design website for some partition options. (<https://rangerdesign.com/>)
- Mountings rails are recommended for any attachment to the vehicle walls.
- All items in the cargo area should be properly secured and partition doors closed while the vehicle is in motion.
- Check your vehicle's tare weight and remaining load capacity with all the equipment installed. Never exceed the maximum Gross Vehicle Weight Rating (GVWR), Gross Axle Weight Ratings (GAWRs), or other maximum loads permitted by the vehicle's Original Equipment Manufacturer (OEM) and required by law.
- The heaviest items must be placed towards the bottom of the vehicle, while the lightest ones can be arranged upwards. Vehicle cargo loading weight proportion should follow the following guidelines:



- The final alterer and/ or modifier should review the warning sheet with the customer before the vehicle is released to the customer or for general use. These instructions should remain with the vehicles at all times.
- Any modification or unintended use of this product voids any warranty and could create a hazardous condition.
- Ranger Design provides recommended assembly and installation instructions which should be followed to ensure correct operation. Failure to do so could result in invalidating the product's compliance, warranty and cause injury. Notwithstanding, the final stage vehicle alterer and/or modifier is responsible for the integration, installation, and compliance of the product in its final location to all applicable regulations and standards. Failure to maintain compliance of the vehicle to applicable regulations and standards could be punishable by law. Alterers and/or modifiers should consult with all local authorities prior to commissioning.



CAUTION

- Drilling is required to complete this installation. Before drilling, ensure that you will not hit any critical parts of the vehicle like the gas tank, wiring harness, or hose. Consult the vehicle OEM documentation as necessary. When drilling, use a drill collar to reduce the risk of damage to the vehicle.
- Any materials, padding, or glazing installed in the vehicle must comply with FMVSS/CMVSS 201/205/302, as applicable.
- In the event of a motor vehicle accident or collision where a Ranger system has been installed, especially ones where the vehicle structure is damaged and/or the air bags deploy and/or the vehicle has been towed, the system must be inspected to ensure continued soundness and safety before returning the vehicle to service. Damaged components should be replaced as necessary.
- All system components should be regularly inspected, cleaned, and maintained pursuant to Ranger guidelines.

QUICK START GUIDE

Phase 1 - Set-up

1.1 Setup..... 4

Phase 2 - Install

2.1 Install 5

REQUIRED ITEMS

- Allen key 6mm
- Ratchet
- 13mm Hex Socket
- Anti Seize (recommended)
- Flat head screwdriver

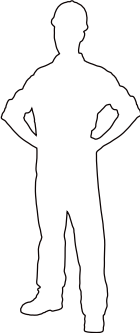

PHASE 1 – ASSEMBLY

1.1 SETUP

1.1.1 Unpack components; compare with the bill of materials.

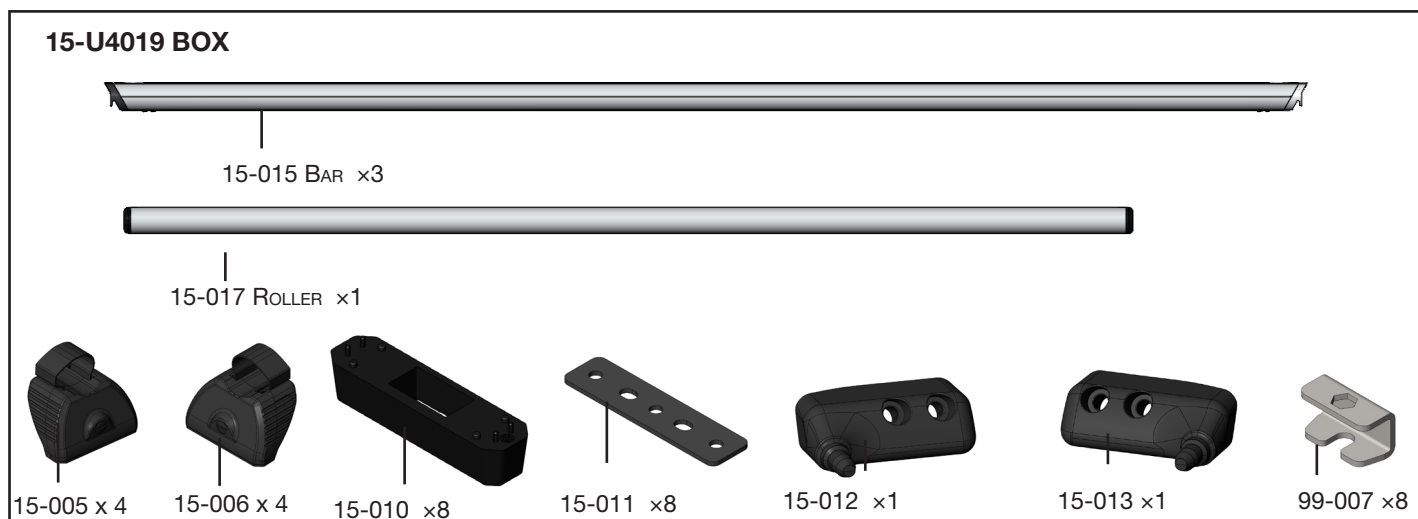
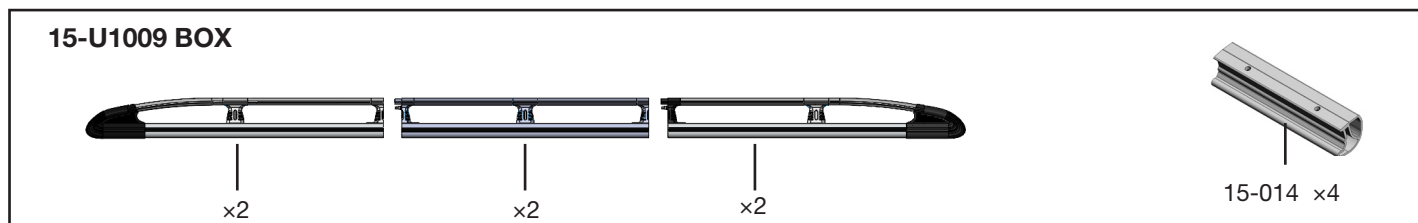

1.1.2 Verify all parts are present

Bill of Material

Item No.	Description	Qty.
15-005	Cargo+ Foot Passenger Side	4
15-006	Cargo+ Foot Driver Side	4
15-010	Cargo+ Shim	8
15-011	Cargo+ Shim	8
15-012	Cargo+ Driver Side Roller Connection	1
15-013	Cargo+ Passenger Side Roller Connection	1
15-014	Cargo+ Side Rail Connection	4
15-015	Cargo+ Cross bar	9
15-017	Cargo+ Roller	1
98-099	M8 Lock Washer Internal Tooth	8
98-129	M8 Flat Washer	8
90-003	Allen Socket M8 x 25mm	30
90-004	Hex Bolt M8 x 1.25 x 50mm	8
99-007	ProMaster Roof Fitting	8
99-010	Cargo+ Side Rail Connector	22

1.1.3 Identify **Assembly** and **Installation** fastener bag.

Assembly Fastener



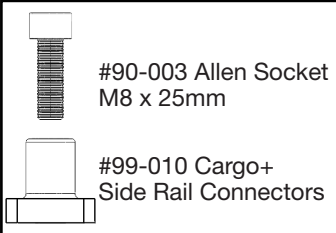

- 30x  # 90-003 Allen Socket M8 x 25mm Rhino Bolt
- 22x  # 99-010 Cargo+ Side Rail Connectors

Hardware Assembly

22x  #90-003 Allen Socket M8 x 25mm
#99-010 Cargo+ Side Rail Connectors

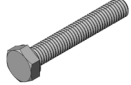
8x  #90-003 Allen Socket M8 x 25mm

Installation Fastener

- 8x  #90-004 Hex Bolt M8-1.25x50mm SS304
- 8x  #98-099 Lock Washer M8 Internal Tooth
- 8x  #98-129 Hex Bolt M8 Flat Washer
- 8x  #99-007 ProMaster Roof Fitting

8x Hardware Assembly

 #90-004 Hex Bolt M8 x 1.25 x 50mm

 #98-099 M8 Lock Washer

 #98-129 M8 Flat Washer

 #99-007 Roof Fitting

PHASE 2 – ASSEMBLY

1.1 ROOF INSTALLATION

1. Remove foot cowlings.

TOOLS

- Flat head screwdriver

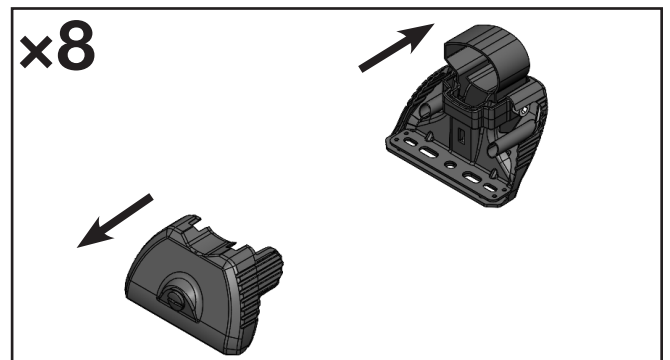
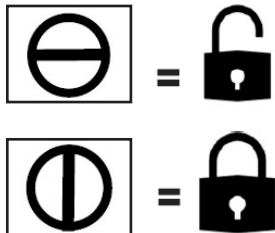

2. Install feet to 4 crossbars.

TOOLS

- Allen key 6mm

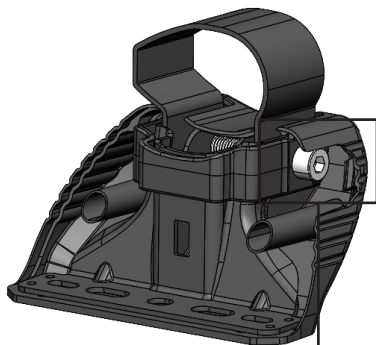

Loosen Bolt

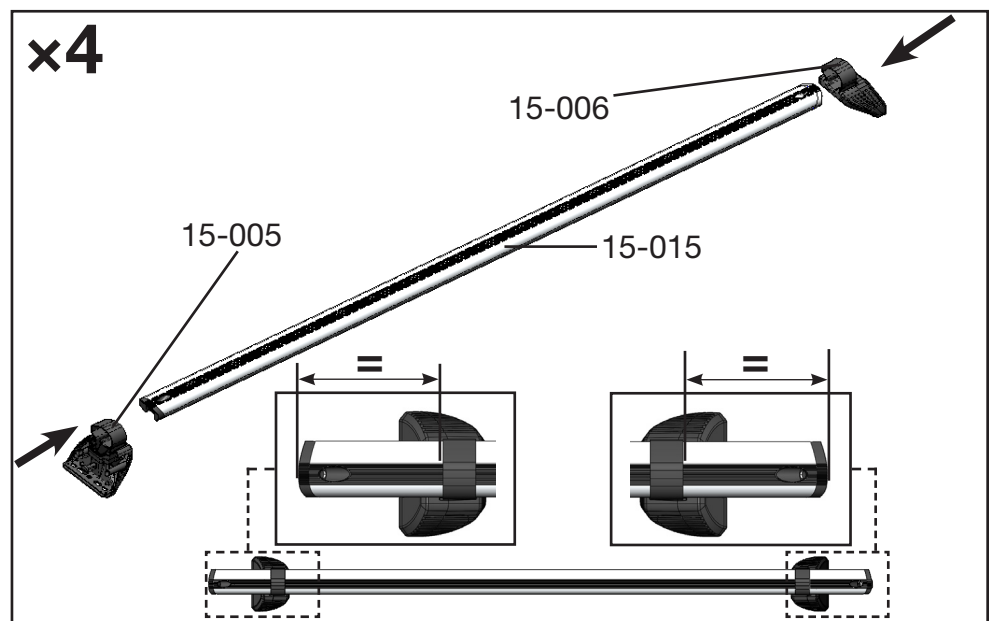

3. Mount feet to van mounting points.

TOOLS

- 13mm Hex Socket
- Ratchet

HARDWARE USED

8X (12 ft • lbs)

- #90-004 Hex Bolt M8
× 1.25 x 50mm
- #98-099 M8 Lock Washer
- #98-129 M8 Flat Washer

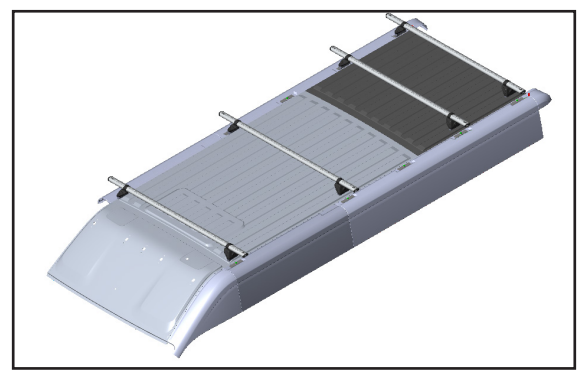
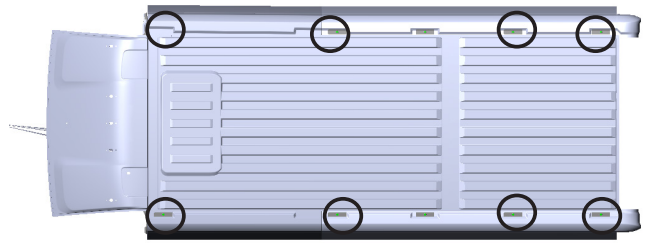
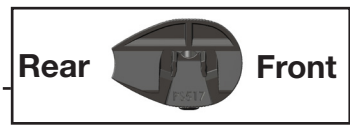
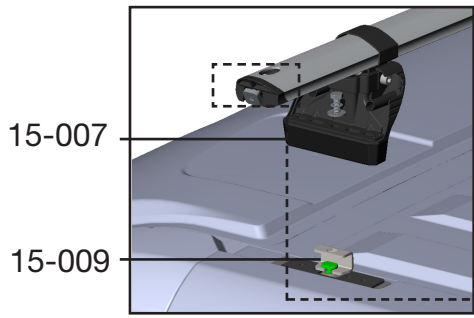

4. Assemble both side rails. Use anti-seize as required.

TOOLS

- Allen key 6mm

HARDWARE USED

8X (7 ft • lbs)

- #90-003 Allen Socket
M8 x 25mm

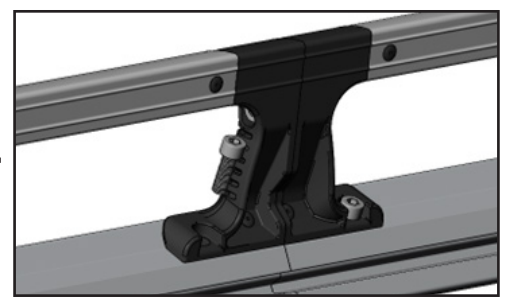
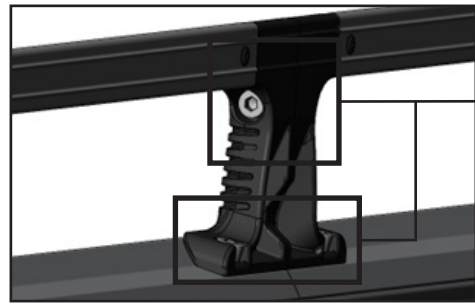
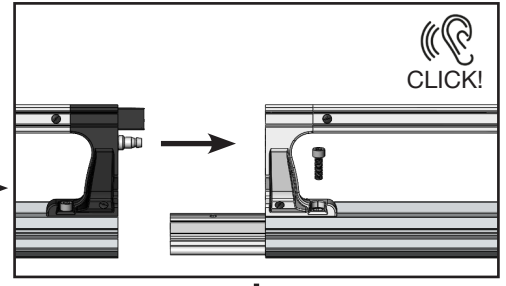
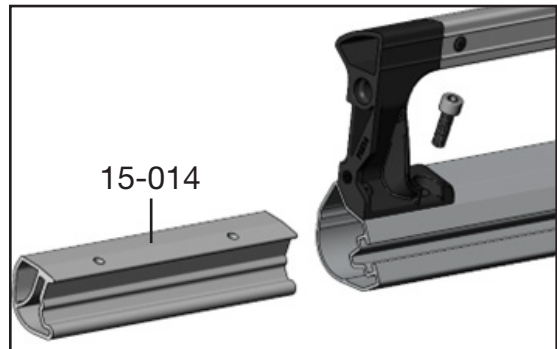

5. Assemble roller.

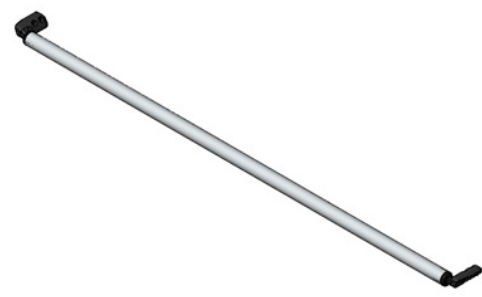
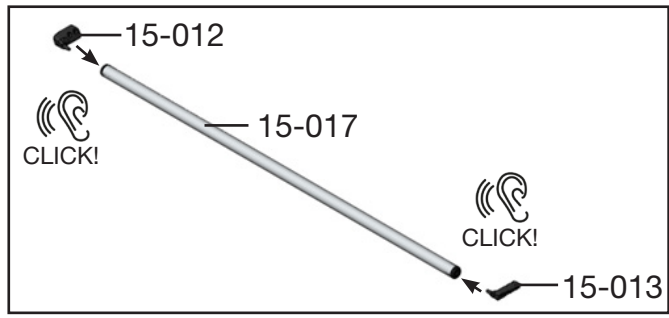

6. Install side rail connectors.

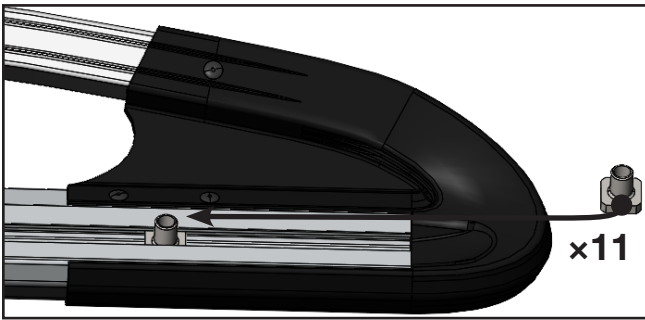

HARDWARE USED

22x



#99-010 Cargo+ Side Rail Connectors

7. Space out the side rail connectors.

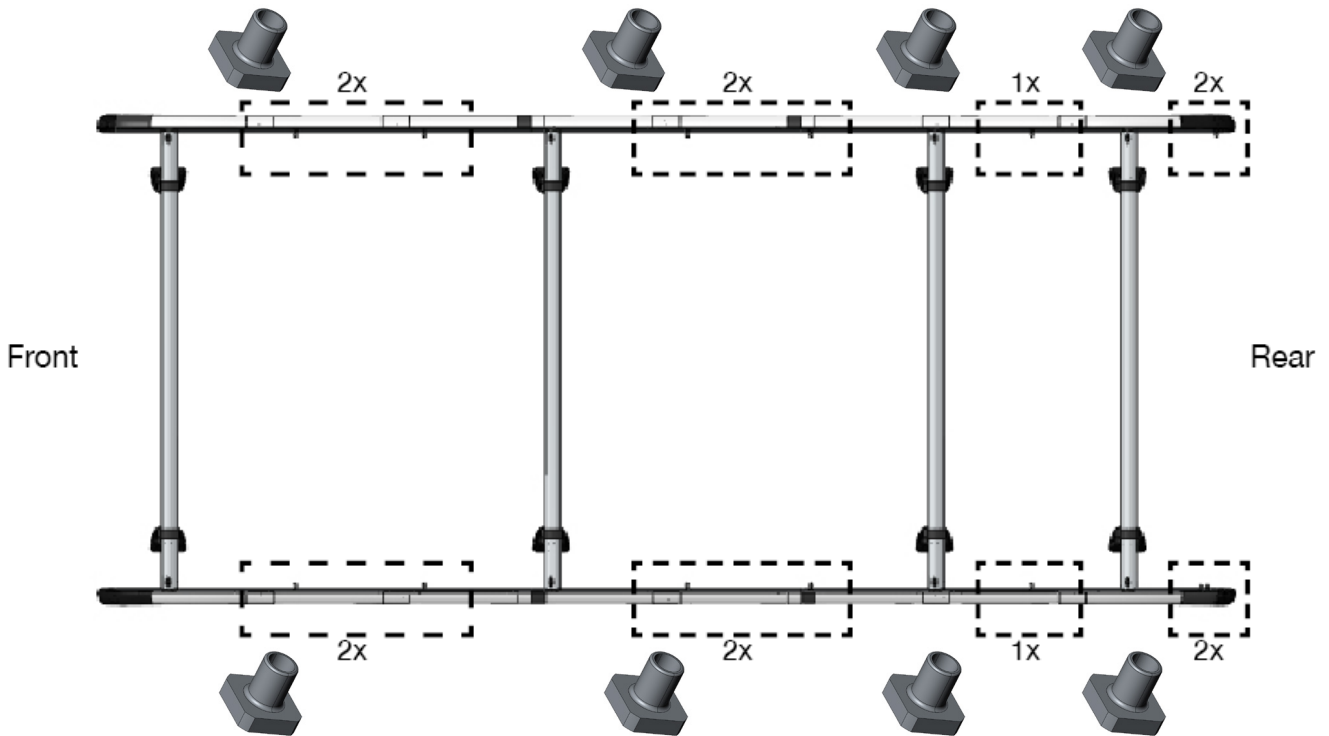

8. Mount side rails to crossbars.

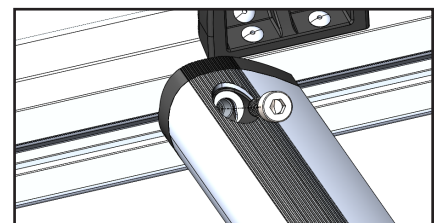
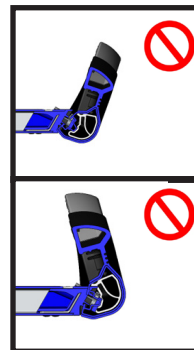
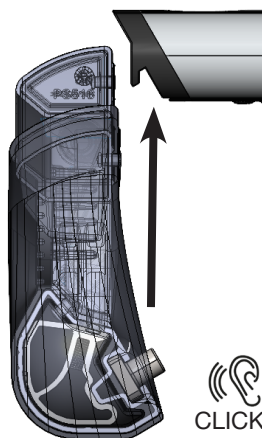
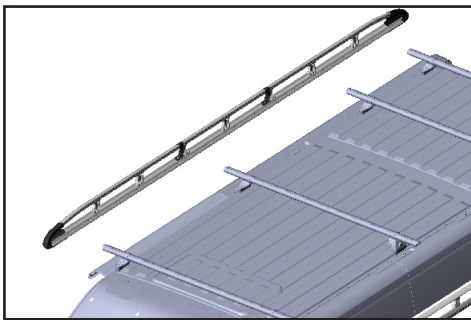

HARDWARE USED

8x (7 ft • lbs)



#90-003 Allen Socket
M8 x 25mm

9. Mount the roller and remaining crossbars, spread out evenly along the side rails.

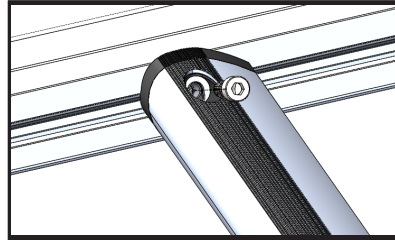
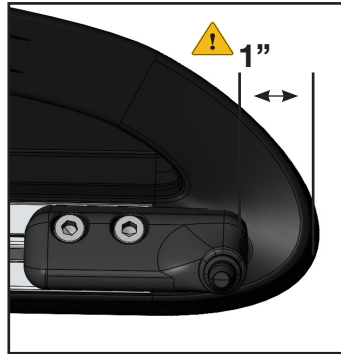
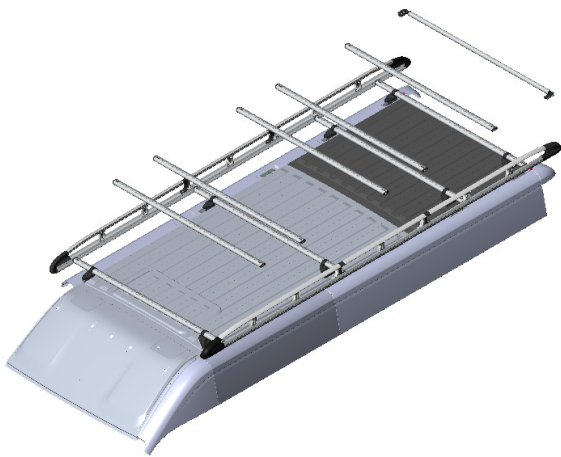

HARDWARE USED

14x (7 ft • lbs)

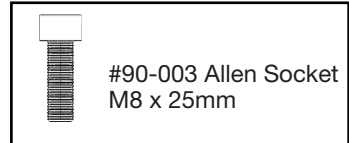

10. Tighten all crossbar bolts. Use anti-seize as required.

TOOLS

- Allen key 6mm

Verify roller clears rear of van and camera

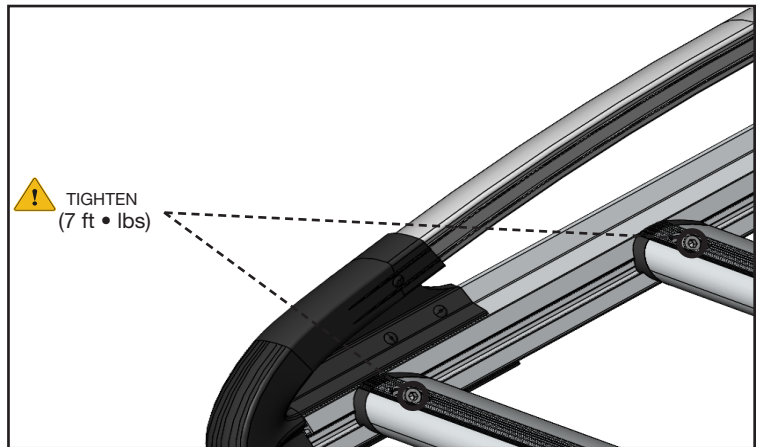
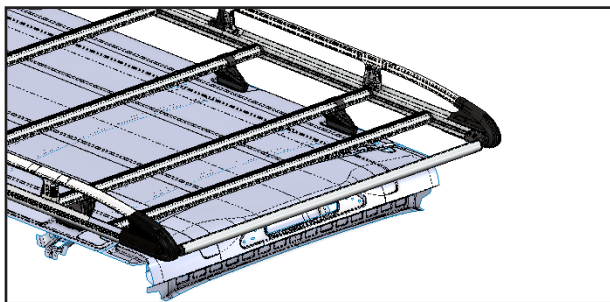

11. Re-attach foot cowl.

TOOLS

- Flat head screw driver

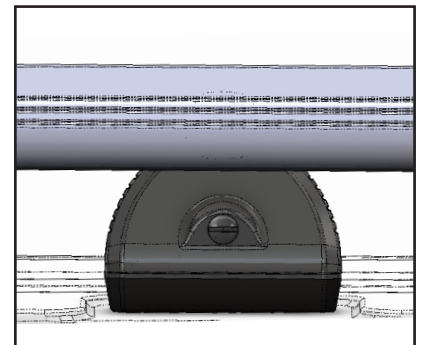
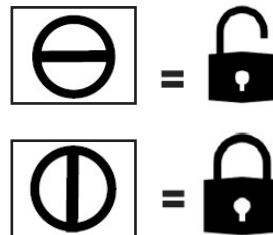
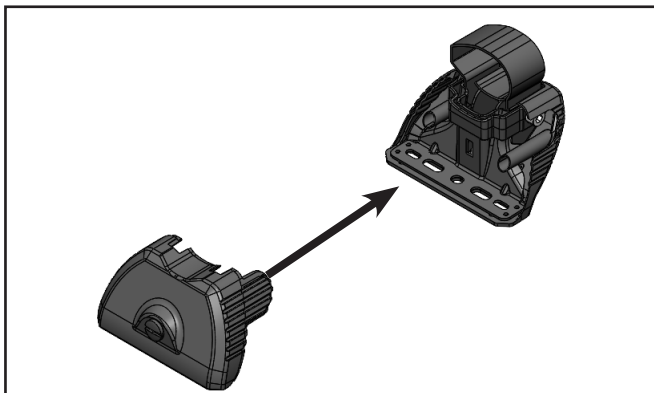

“You have successfully installed your Cargo +, thank you for doing business with us.”

For any feedback or suggestions, you may have, please contact: cs@rangerdesign.com