

# INSTALLATION GUIDE

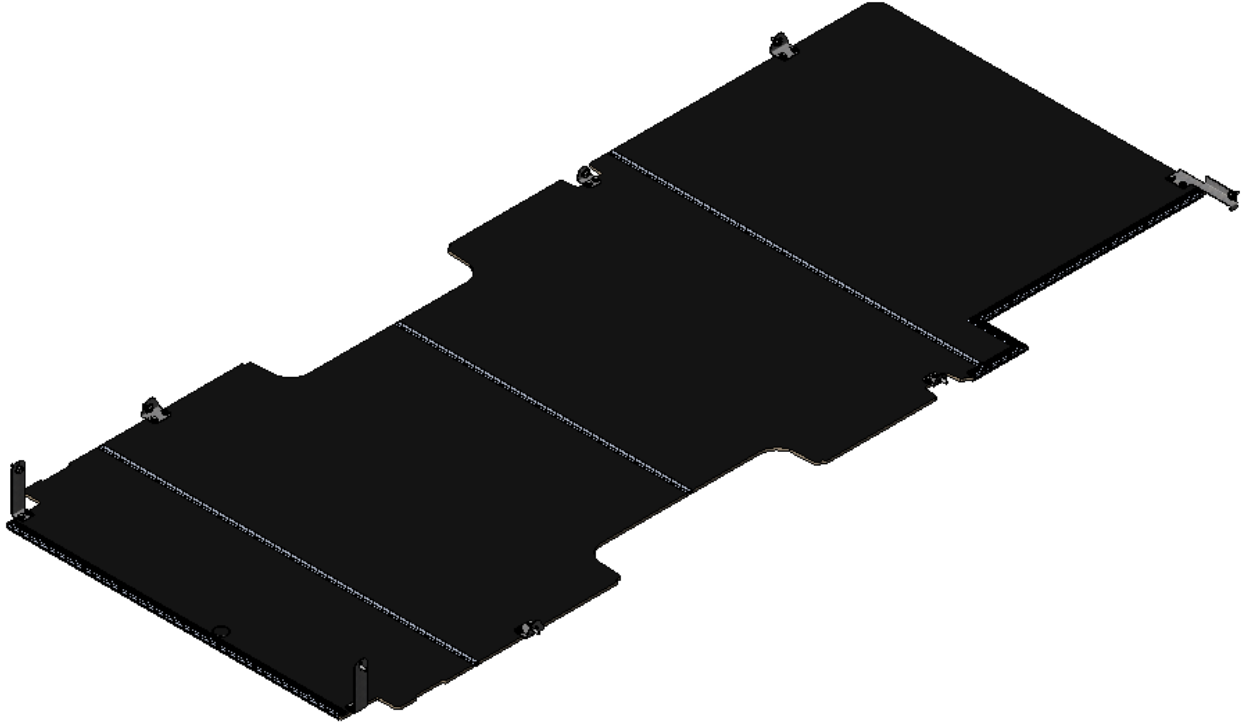

## 6541-FTX

No-Drill Floor  
Ford Transit 148" Ext.



Scan the QR  
code for digital  
Install-Guide



## SAFETY INSTRUCTIONS

### WARNING

- Before the installation, carefully read the supplied installation guide to avoid possible injuries and damages resulting from incorrect installation. Always keep the installation guide in an accessible location at all times for reference during installation.
- Installers must always wear appropriate safety gear during installation. This may include but is not limited to gloves, steel toed shoes, and safety glasses.

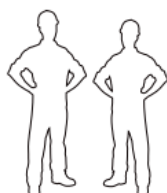

2  
PERSONS

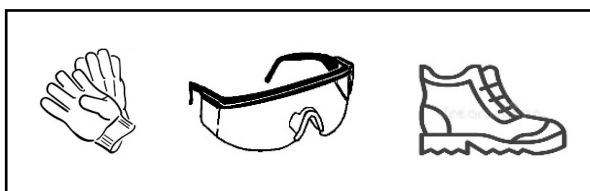

### CAUTION

- Follow all vehicle manufacturer instructions before attempting any installation.
- To prevent rust and other damages, do not drill into the factory floor panels.
- Before drilling for the tapping inserts, use a drill stop collar to prevent accidental drilling the van metal floor panel which may result in damage to components underneath, such as wiring harnesses, fuel tanks and battery modules.

## PREPARATION

### Tools Needed

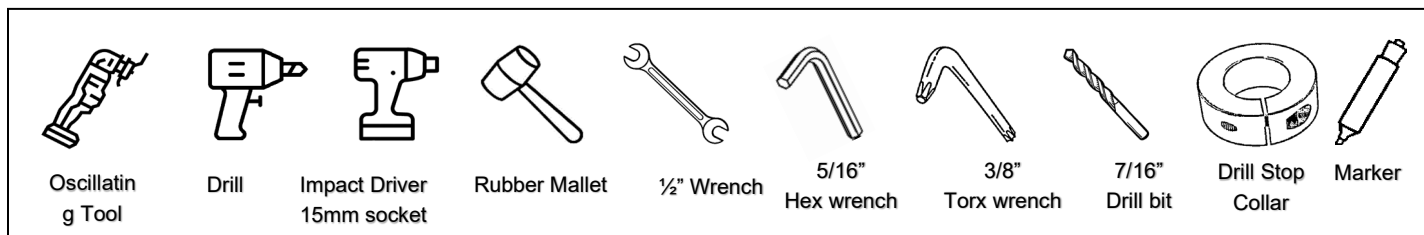

## BILL OF MATERIALS

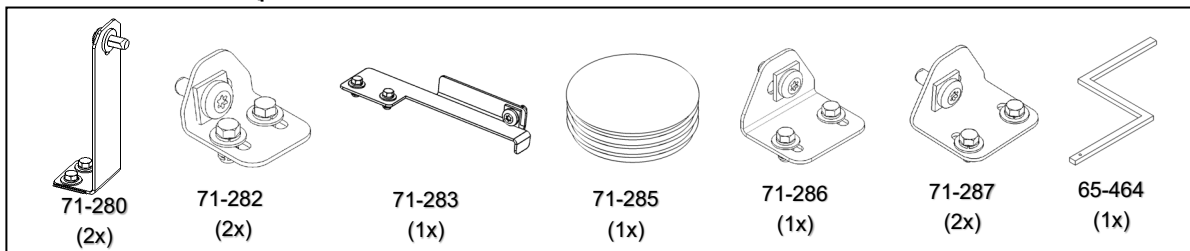
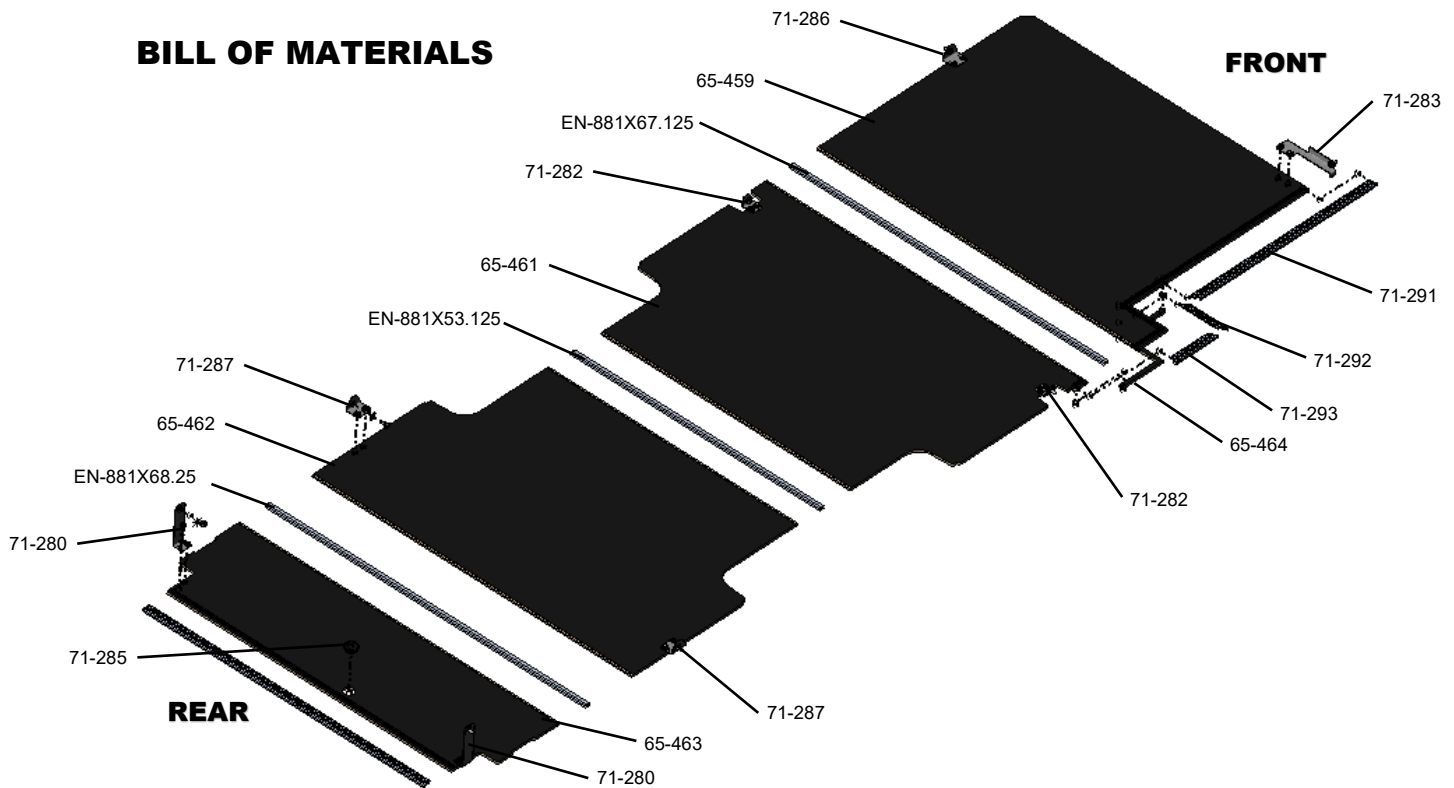

### Assembly Fastener Kit (94-6502)

Item No:	Description	Qty.
90-010	Screw-Torx, thread rolling, pan head, 7/16 – 20x28mm T-50 taptime	6
90-204	Bolt hex head 5/16" – 18 x 3/4" GR-5 zinc	16
92-200	Screw hex flanged head, self-drilling, #10-16 x 3/4", zinc	6
98-116	Washer, flat, 5/16", 7/8" OD, zinc	16
98-122	Washer, lock spring, regular, 5/16" zinc.	16
98-141	Square, flat washer, 0.438" ID, 1.000" square	6
99-114	Zinc alloy tapping inserts for softwood, 5/16 – 18, internal thread	16
90-981	Zinc-plated, steel, thread cutting screws for metal	2

### Install Fastener Kit (96-6500)

Item No:	Description	Qty.
90-204	Bolt hex head 5/16" – 18 x 3/4" GR-5 zinc	30
99-114	Zinc alloy tapping inserts for softwood, 5/16 – 18, internal thread	30

### Bill of Materials

Item No:	Description	Qty.
65-459	Floor Panel (Front)	1
65-461	Floor Panel (Middle-Front)	1
65-462	Floor Panel (Middle-Rear)	1
65-463	Floor Panel (Rear)	1
65-464	Shim, Floor	1
EN-881 x 53.125	I-Beam Extrusion (53.125")	1
EN-881 x 67.125	I-Beam Extrusion (67.125")	1
EN-881 x 68.25	I-Beam Extrusion (68.25")	1
EN-884 x 60	Sill Extrusion (60")	1
71-291	Sill Extrusion w/ 1 45deg cut (41.50")	1
71-292	Sill Extrusion w/ 2 45deg cuts (9.62")	1
71-293	Sill Extrusion w/ 1 45deg cut (9.63")	1
71-280	Floor Bracket, Power Pro	2
71-282	Floor Bracket, B-Pillar	2
71-283	Bracket, Floor to D-Ring	1
71-285	Snap-in Plug	1
71-286	Transit Floor Bracket	1
71-287	Transit Floor Bracket	2
94-6502	Assembly Fastener Kit	1
96-6500	6541 Series Floor Fastener Kit	1

ASSEMBLY

**STEP 1**

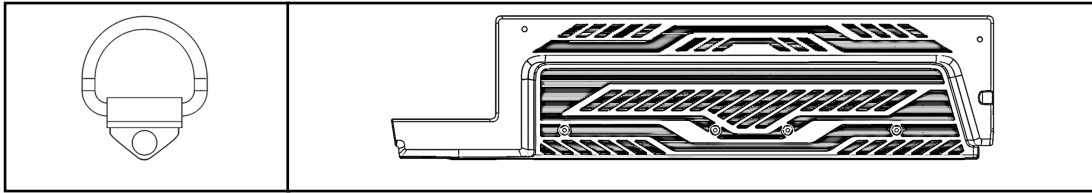

If needed, remove D-rings and Sliding door sill.

**STEP 2**

**Tools:**

- Rubber Mallet

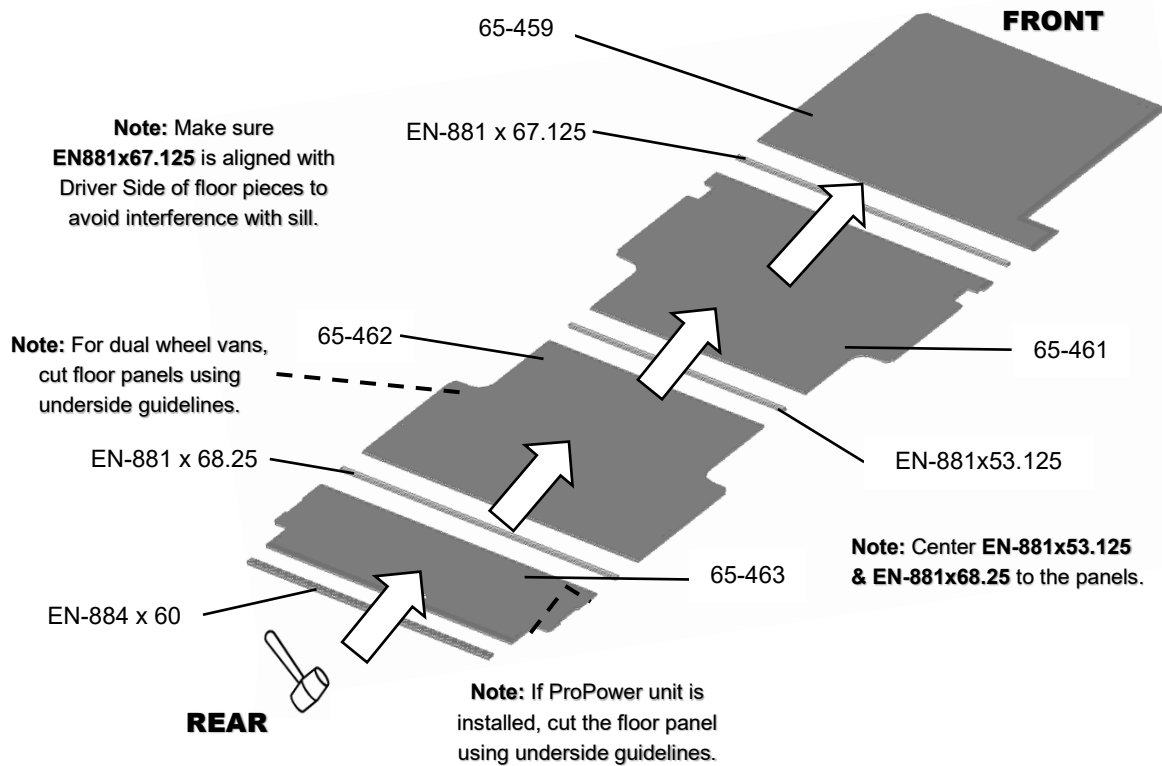

**STEP 3**

71-280  
65-463  
71-280

3/4" wrench  
1/2" wrench  
5/16" Hex  
7/16" Drill bit

Torque to 17 ft-lbs.		
	90-981	2x
Torque to 17 ft-lbs.		
	90-204	4x
	98-122	4x
	98-116	4x
	99-114	4x

**STEP 4**

71-287  
65-462  
71-287

1/2" wrench  
3/8" Torx  
5/16" Hex  
7/16" Drill bit

Torque to 17 ft-lbs.		
	90-010	2x
	98-141	2x
Torque to 17 ft-lbs.		
	90-204	4x
	98-122	4x
	98-116	4x
	99-114	4x

**STEP 5**

71-282  
65-461  
71-282

1/2" wrench  
3/8" Torx  
5/16" Hex

Torque to 17 ft-lbs.		
	90-010	2x
	98-141	2x
Torque to 17 ft-lbs.		
	90-204	4x
	98-122	4x
	98-116	4x

**STEP 6**

65-461  
65-464

**Note:** The hole on the shim should be oriented to the front of the vehicle.

**Note:** Make sure the sill cutouts are aligned before installing the sill.

### STEP 7

71-286

65-459

71-283

1/2" wrench

3/8" Torx

5/16" Hex

7/16" Drill bit

Torque to 17 ft-lbs.

90-010 2x

98-141 2x

Torque to 17 ft-lbs.

90-204 4x

98-122 4x

98-116 4x

99-114 4x

71-283 (1x)

Do not install 71-283 if you are installing a Ranger Design partition on top of the Ranger Design floor.

### STEP 8

FRONT

71-291

71-292

71-293

EN-884x60

71-285

REAR

Note: Align sill pieces and floor cutouts before installing.

71-291

Note: Cut as required if the vehicle has a partition.

Note: Center sill before installing.

**STEP 9 – For Scuff Plate Only**

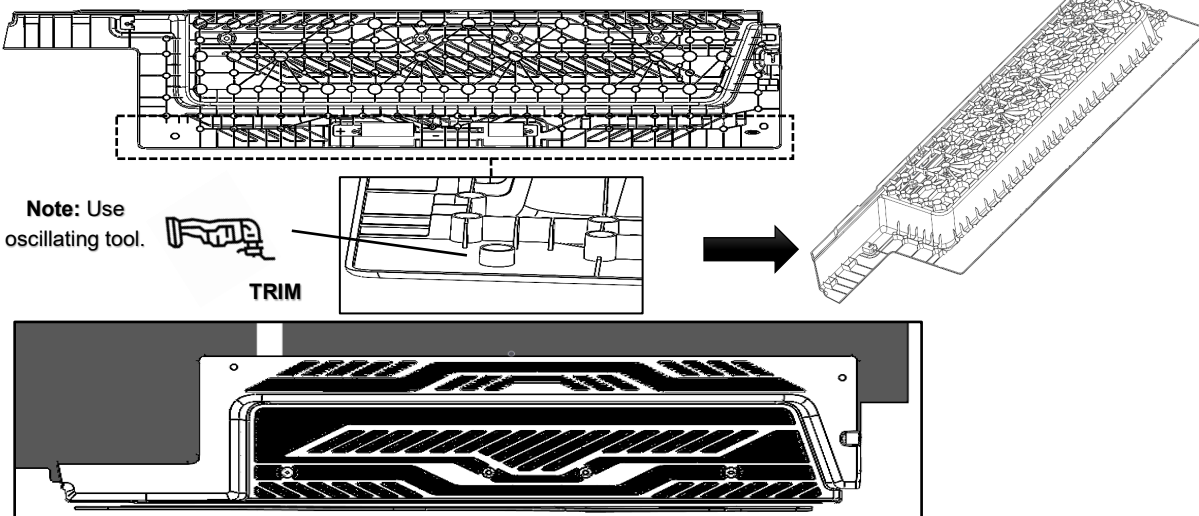

**STEP 10 – For Composite Partition only**

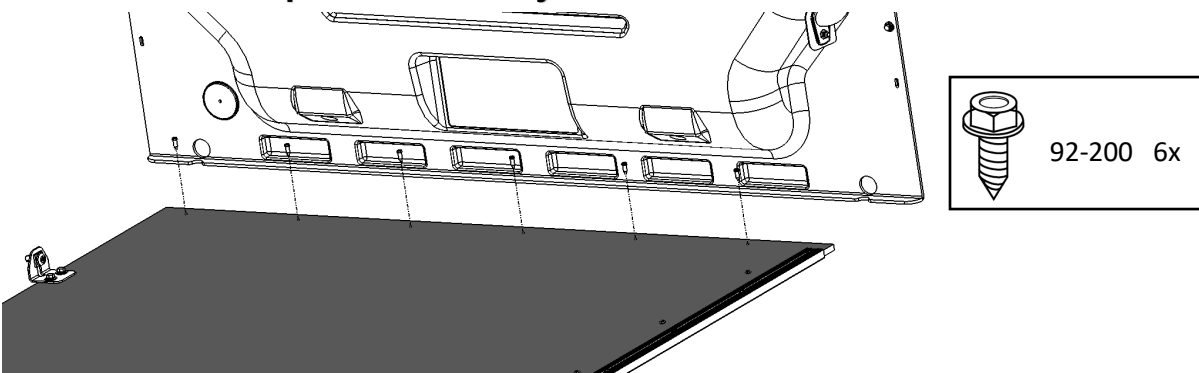

**STEP 11 - Units (Including shelf, drawer, work bench, locker, etc.)**

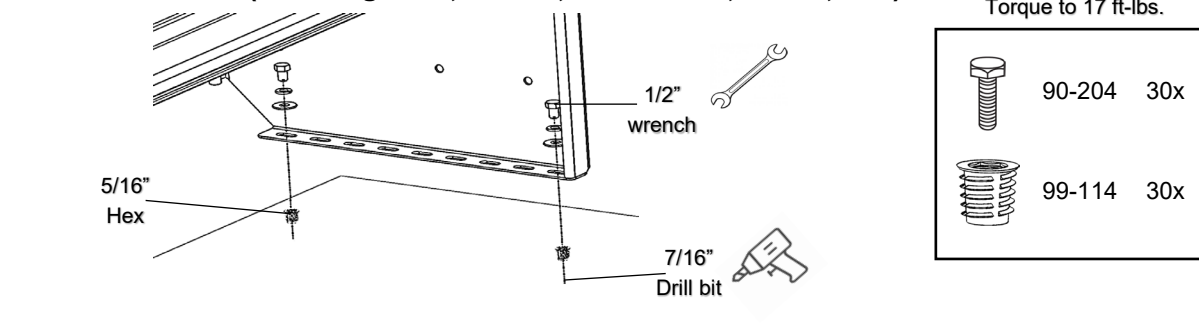

**“You have successfully installed your 6541-FTX, thank you for doing business with us.”**

For any feedback or suggestions, you may have, please contact: [cs@rangerdesign.com](mailto:cs@rangerdesign.com)

