

# INSTALLATION GUIDE

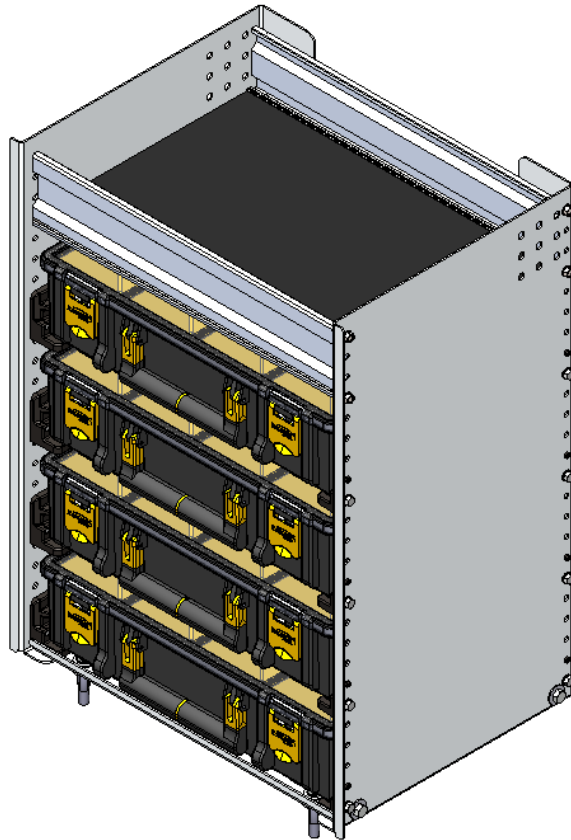

## C2-PA18-4C Partskeeper Cabinet



Scan the QR for the latest Install-Guide.





# BEFORE YOU BEGIN

READ, UNDERSTAND, AND FOLLOW ALL WARNINGS AND INSTRUCTIONS BEFORE USING THIS PRODUCT. FAILURE TO FOLLOW THESE DIRECTIONS MAY RESULT IN PROPERTY DAMAGE, SERIOUS BODILY INJURY, AND/OR DEATH. RANGER DESIGN IS NOT RESPONSIBLE FOR ANY PROPERTY DAMAGE, PERSONAL INJURY, OR DEATH THAT OCCURRED WHILE USING ANY RANGER DESIGN PRODUCTS.



## WARNING

- Failure to use Ranger Design-provided fasteners, brackets, and proper installation guidelines could increase risk of serious personal injury and/or death.
- If drilling is required to complete this installation: improper drilling can cause property damage to vehicles and could lead to electric shock, fire, or even death.
- If drilling is required to complete this installation: Ensure that drilling is only performed on areas of the vehicle allowed by the vehicle's Original Equipment Manufacturer's Body Builders Layout Book (or equivalent document).
- Prior to installation, inspect the vehicle to ensure that installation will not interfere with, or cause obstruction of, any critical components such as electrical wiring, fuel tanks, fuel-cells, locks, latches, etc.
- The installer or manufacturer is responsible for ensuring anchorages are installed onto suitable wall and floor structures; wall and floor strength must meet applicable performance requirements.
- Do not install systems into any weak or unsound materials such as plastics, woods, thin-walled metals, etc. without proper reinforcement.
- Do not install this product where it could interfere with the deployment of airbags. Failure to comply could result in death or serious injury.
- Do not install this product where it could ingress on the Transit Occupant Protection Zone. Failure to comply could result in death or serious injury.
- Incorrect installation could cause water leaks, electric shock or fire.
- Any cargo vehicle with any cargo or equipment should use a certified partition. See Ranger Design website for some partition options. (<https://rangerdesign.com/>)
- Mountings rails are recommended for any attachment to the vehicle walls.
- All items in the cargo area should be properly secured and partition doors closed while the vehicle is in motion.
- Check your vehicle's tare weight and remaining load capacity with all the equipment installed. Never exceed the maximum Gross Vehicle Weight Rating (GVWR), Gross Axle Weight Ratings (GAWRs), or other maximum loads permitted by the vehicle's Original Equipment Manufacturer (OEM) and required by law.
- The heaviest items must be placed towards the bottom of the vehicle, while the lightest ones can be arranged upwards. Vehicle cargo loading weight proportion should follow the following guidelines:

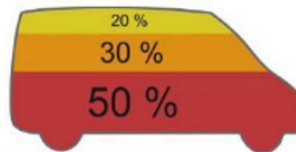

- The final alterer and/ or modifier should review the warning sheet with the customer before the vehicle is released to the customer or for general use. These instructions should remain with the vehicles a all times.
- Any modification or unintended use of this product voids any warranty and could create a hazardous condition.
- Ranger Design provides recommended assembly and installation instructions which should be followed to ensure correct operation. Failure to do so could result in invalidating the product's compliance, warranty and cause injury. Notwithstanding, the final stage vehicle alterer and/or modifier is responsible for the integration, installation, and compliance of the product in its final location to all applicable regulations and standards. Failure to maintain compliance of the vehicle to applicable regulations and standards could be punishable by law. Alterers and/or modifiers should consult with all local authorities prior to commissioning.



## CAUTION

- Drilling is required to complete this installation. Before drilling, ensure that you will not hit any critical parts of the vehicle like the gas tank, wiring harness, or hose. Consult the vehicle OEM documentation as necessary. When drilling, use a drill collar to reduce the risk of damage to the vehicle.
- Any materials, padding, or glazing installed in the vehicle must comply with FMVSS/CMVSS 201/205/302, as applicable.
- In the event of a motor vehicle accident or collision where a Ranger system has been installed, especially ones where the vehicle structure is damaged and/or the air bags deploy and/or the vehicle has been towed, the system must be inspected to ensure continued soundness and safety before returning the vehicle to service. Damaged components should be replaced as necessary.
- All system components should be regularly inspected, cleaned, and maintained pursuant to Ranger guidelines.

# QUICK START GUIDE

## Phase 1 - Assembly

<input type="checkbox"/> 1.1 Setup.....	4
<input type="checkbox"/> 1.2 Shelf Assembly.....	7

## Phase 2 - Installation

<input type="checkbox"/> 2.1 Mark Holes For Plus Nuts.....	9
<input type="checkbox"/> 2.2 Attach Plus Nut.....	10
<input type="checkbox"/> 2.3 Attach Partskeeper Cabinet To the Floor.....	12

# REQUIRED ITEMS

- Cordless Impact
- Cordless Drill
- Tape Measure
- Marker
- 1/2" Socket
- 1/2" Drill Bit w/ Drill Collar ( Set at 1/2" )
- 3/8" Driver Bit
- Knife
- Plusnut Tool / Plusnut Gun ( 5/16" )

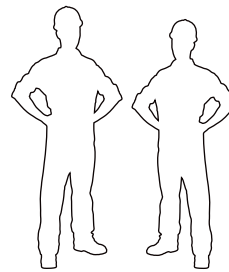

**2**  
**PERSONS**

# PHASE 1 – ASSEMBLY

## 1.1 SETUP

1.1.1 Unpack components; compare with the bill of materials.

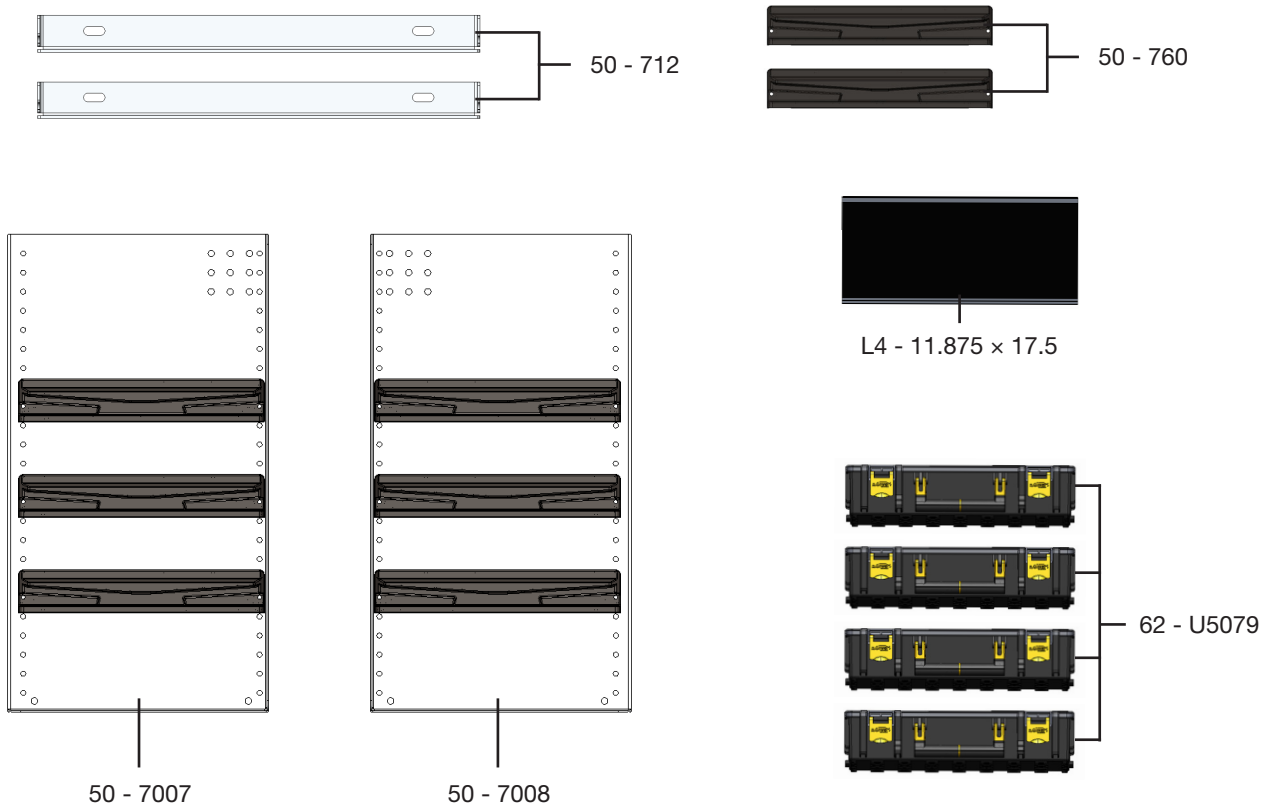

1.1.2 Verify all parts are present.

### BILL OF MATERIALS

Item No.	Description	Qty.
50 - 712	Floor Bracket	2
50 - 760	Partskeeper Rail	2
50 - 7007	End Panel ( Left )	1
50 - 7008	End Panel ( Right )	1
62-U5079	Plastic Partskeeper Case	4
L4 - 11.875 x 17.5	Shelf Tray, Composite, Usable 12" x 17.5"	1
94 - 5021	Assembly Fastener Kit	1
96 - 5021	Install Fastener Kit	1

1.1.3 Fastener kits.

94 - 5021 Fastener Kit

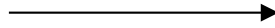

Fastener Assembly

4x



# 90-204

Hex Bolt  
5/16"-18 x 3/4"  
GR-5 ZINC

4x



#90-204 Hex Bolt 5/16" x 3/4"



#98-116 Flat Washer 5/16"



#94-116 Serrated Nut 5/16"

4x



# 90-012

Screw HWH  
1/4"-10 x 3/4"  
ZINC

4x



#90-012 Screw 1/4"-10 x 3/4"

8x



# 92-102

Screw HWH  
#14 x 1"  
ZINC

8x



#92-102 Screw #14 x 1"

4x



# 94-116

Serrated Nut  
5/16"-18  
ZINC

4x



# 98-116

Flat Washer  
5/16"  
ZINC

96 - 5021 Fastener Kit

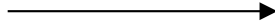

Fastener Assembly

4x  # 90-011 Hex Bolt  
5/16"-18 x 1-3/4"  
GR-5 ZINC





4x  # 94-132 Plusnut

4x  # 98-116 Flat Washer  
5/16", O.D. 7/8"  
ZINC

4x  # 98-122 Lock Washer  
5/16"  
ZINC

4x  # 98-157 Spacer  
0.375" ID, x 1.0" OD x 0.25" LONG  
NYLON

4x

	#90-011 Hex Bolt 5/16" x 1-3/4"
	#98-122 Lock Washer
	#98-116 Flat Washer
	#98-157 Spacers ( QTY = GAP BETWEEN FLOOR AND END PANEL )
	#94-132 5/16" Plusnut

# PHASE 1 – ASSEMBLY

## 1.2 SHELF ASSEMBLY

1.2.1 Attach both panels to the shelf trays.

**IMPORTANT:** Assemble the partskeeper on a protected clean surface to avoid scratching.

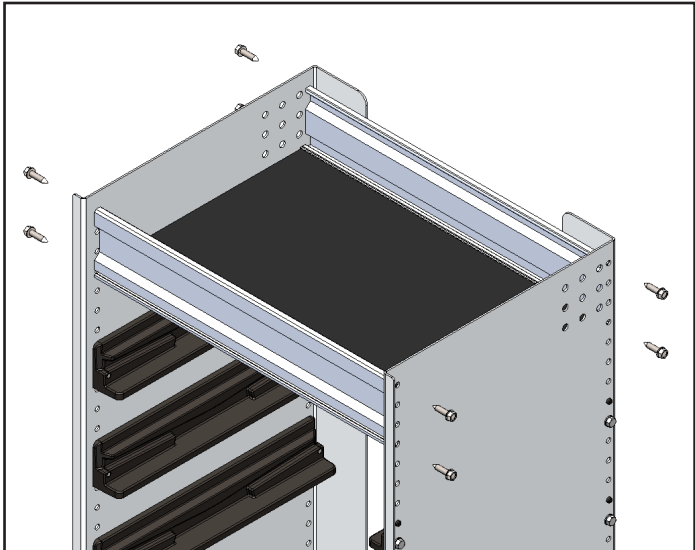
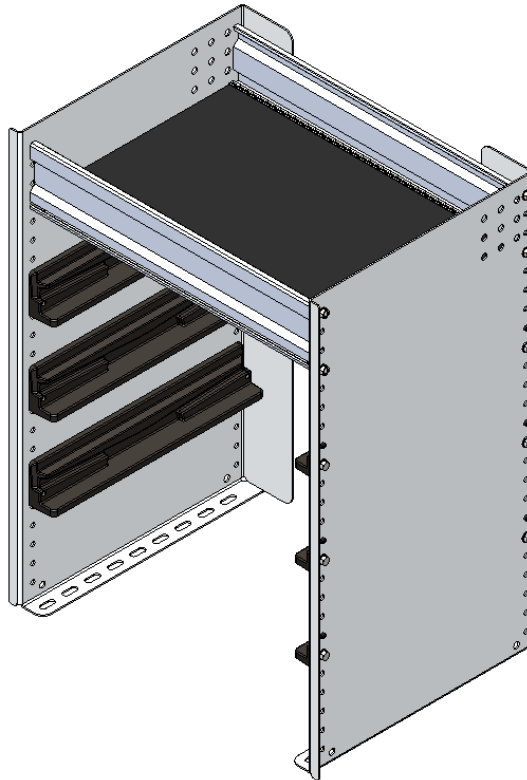

**TOOLS**

- Cordless Impact
- 3/8" Driver Bit

**HARDWARE USED**

**8x** 94-5022



#92-102 Screw #14 x 1"

**1.2.3** Attach 2 bottom brackets to the end panels.

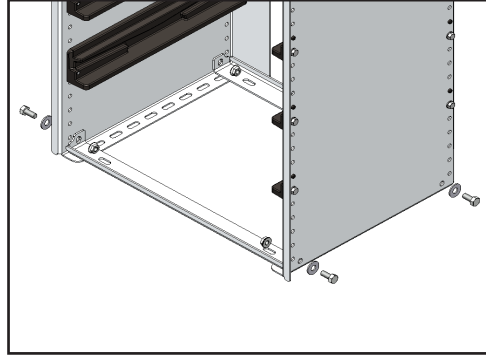
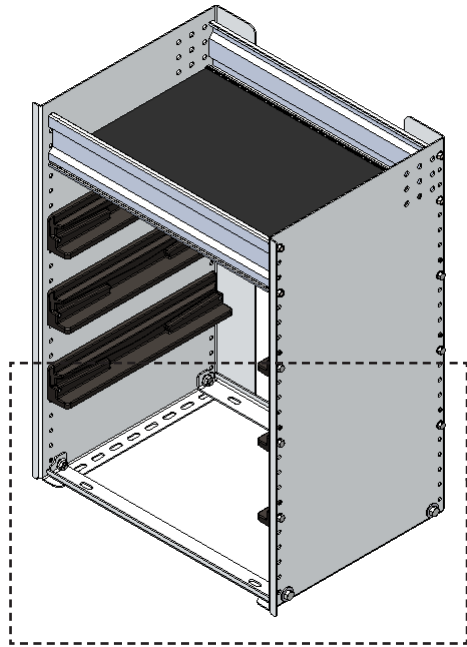



**TOOLS**

- Cordless Impact
- 1/2" Socket

**HARDWARE USED**

**4x** 94-5022

-  #90-204 Hex Bolt 5/16" x 3/4"
-  #98-116 Flat Washer
-  #94-116 Serrated Nut

**1.2.4** Attach 1 partskeeper rail on the bottom of each end panel.

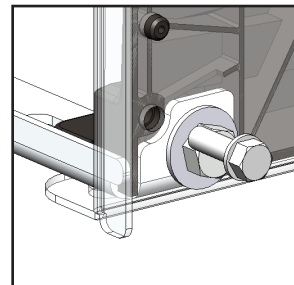
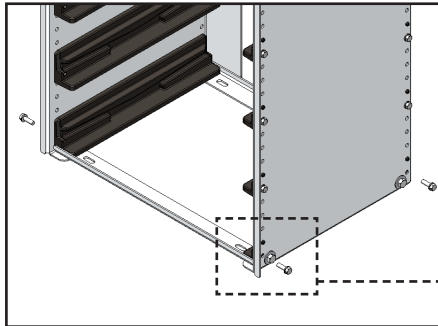
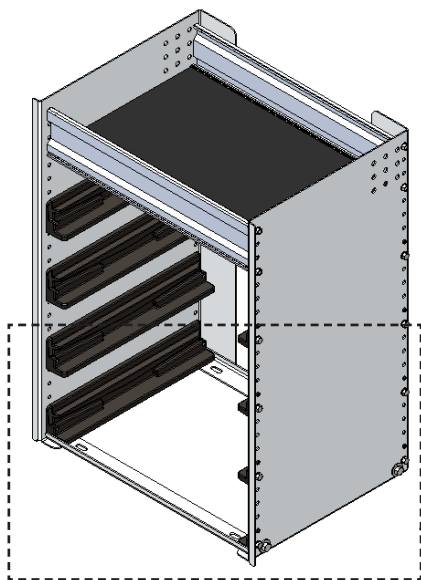

**TOOLS**

- Ratchet
- 3/8" Driver Bit

**HARDWARE USED**

**4x** 94-5022

-  90-012 Screw 1/4"-10 x 3/4"

# PHASE 2 – INSTALLATION

## 2.1 MARK HOLES FOR PLUS NUTS

2.1.1 Lift the assembled partskeeper into the van, then mark the holes on the bottom brackets to the vehicle.

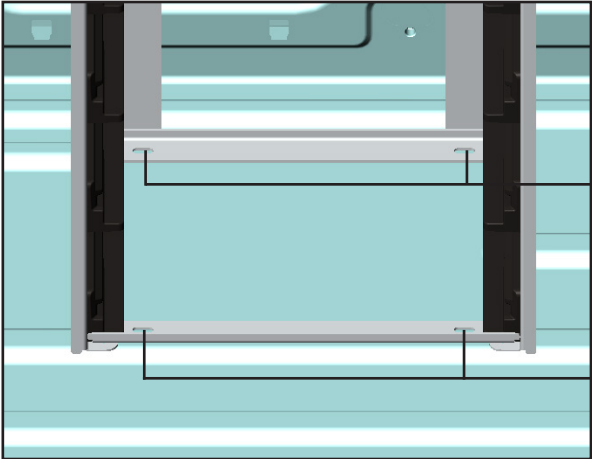
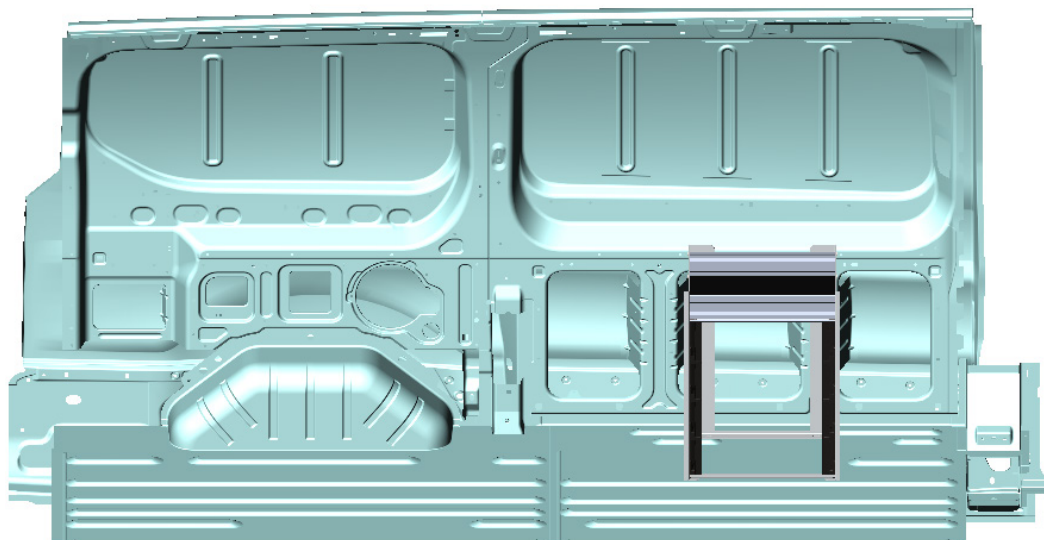

Mark the 2 holes of each floor bracket on the vehicle floor.

**NOTE:** If you are using Ranger floor, please go to **PAGE 12**.

**TOOLS**

- Marker

MARK

# PHASE 2 – INSTALLATION

## 2.2 ATTACH PLUS NUTS

- 2.2.1 • Lift the assembled partskeeper cabinet on the side.  
• Drill all the marks using 1/2" drill bit w/ drill collar, then attach plus nuts to the holes.

**NOTE:** Use 1/2" drill bit with drill collar to stop drill at 1/2" depth.

**WARNING:** Before drilling, ensure that you will not hit any critical parts of the vehicle like the **Gas tank**, **Wiring Harness** and **Hose**.

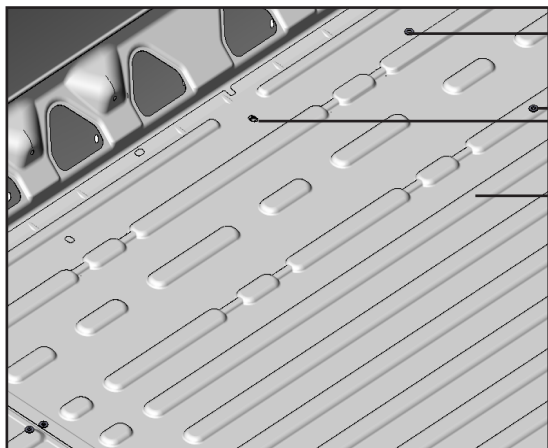
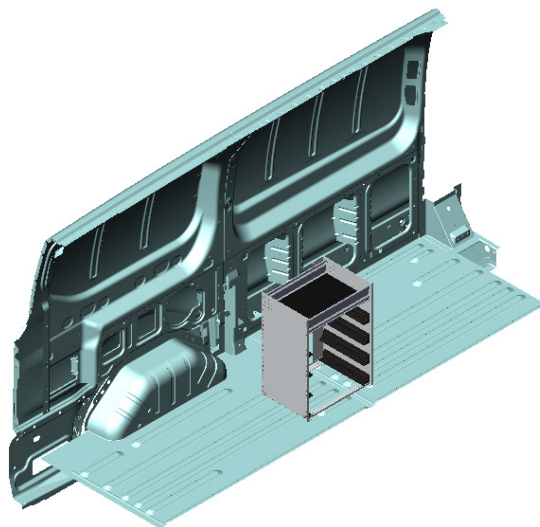

PLUSNUT

Drill all the marks then, attach plus nuts to the holes.

### TOOLS

- Cordless Drill
- 1/2" Drill Bit w/ Drill Collar ( Set at 1/2" )
- Plus Nut Tool ( 5/16" )

### HARDWARE USED

**4x** 96-5013



#94-132 Plus Nut



DRILL COLLAR  
( SET AT 1/2" )

## 2.2.2 How to attach plus nut.

### • USING PLUSNUT GUN

**STEP:** Put the plusnut on the plusnut gun, then attach the plus nut in the hole by turning the gun forward until the plus nut locks, then remove the gun by turning in reverse.

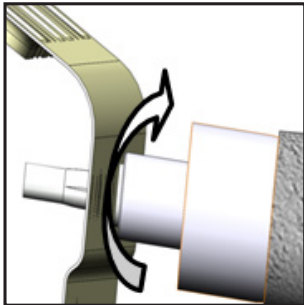

**FORWARD**

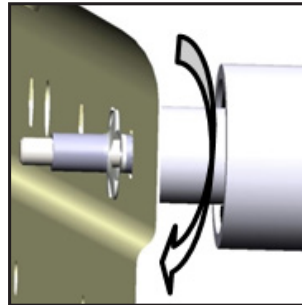

**REVERSE**

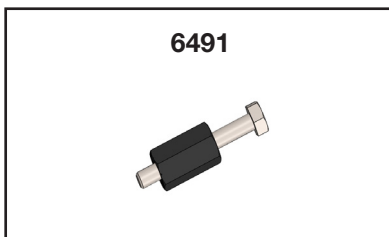

### • USING THE 6491 PLUSNUT TOOL

**NOTE:** The hardware used for the 6491 plusnut tool is not included in the fastener bag. The 6491 plusnut tool can be ordered separately upon demand at no charge.



**6491**

#### HARDWARE USED

-  Flat washer 5/16"
-  Flat washer 5/16" BS x 7/8" OD

#### TOOLS

- Cordless Impact
- 1/2" Socket
- 9/16" Wrench

#### STEP 1:

Assemble the 6491 plusnut tool with the hardware needed, plus nut and the 9/16" wrench as shown.



#### STEP 2:

Attach the plus nut in the hole by turning the bolt forward using an impact with a 1/2" socket until the plusnut locks, then remove the bolt by turning the impact in reverse.

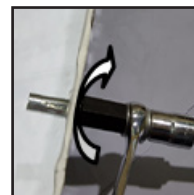

**FORWARD**



**REVERSE**

# PHASE 2 – INSTALLATION

## 2.3 ATTACH PARTSKEEPER CABINET UNIT TO THE FLOOR

### WITHOUT RANGER FLOOR

2.3.1 Put the assembled partskeeper cabinet back in place aligning the holes to the plusnuts, then install the bottom shelf to the plus nuts.

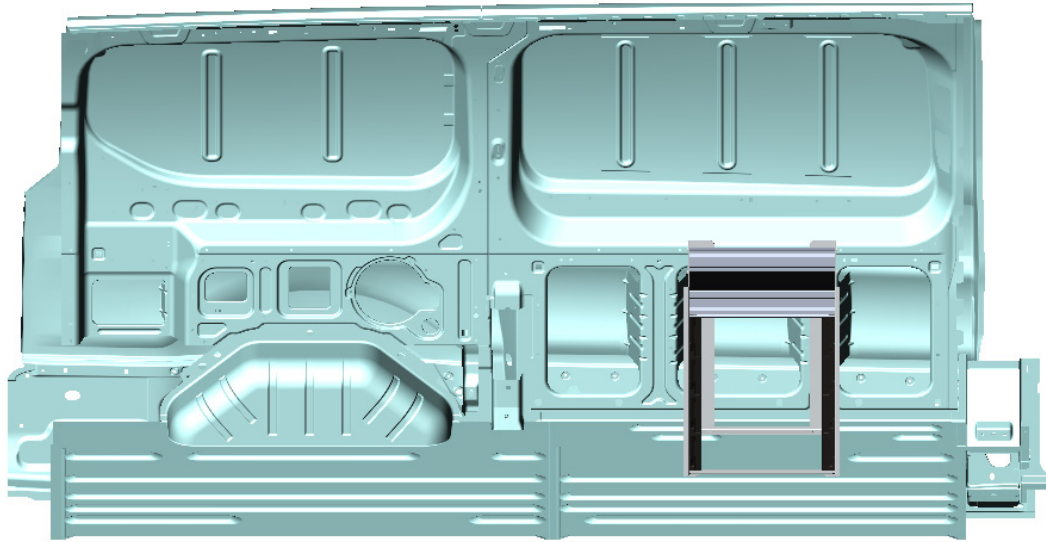





**TOOLS**

- Cordless Impact
- 1/2" Socket

**HARDWARE USED**

**4x 96-5013**

	#90-011 Hex Bolt 5/16" x 1-3/4"
	#98-122 Lock Washer
	#98-116 Flat Washer
	#98-157 Spacers ( QTY = GAP BETWEEN FLOOR AND END PANEL )
	#94-132 5/16" Plusnut

## WITH RANGER FLOOR

- 2.3.2**
- Lift the partskeeper cabinet inside the van, then put it in place.
  - Mark the 2 holes of each floor bracket, then place the partskeeper cabinet on the side.
  - Drill the marks on the floor using 1" hole saw, then drill holes into the van floor for plus nut.
  - Attach plus nut in the van floor, then lift the partskeeper cabinet back in place, and attach the floor bracket to the plus nut.

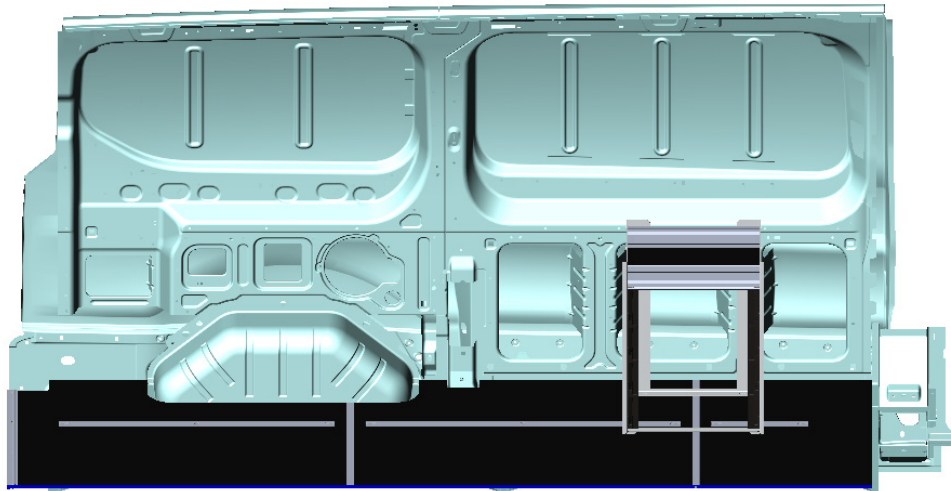





### TOOLS

- Cordless Impact
- Cordless Drill
- 1/2" Drill Bit w/ Drill Collar ( Set at 1/2" )
- Plus Nut Tool ( 5/16" )
- 1/2" Socket
- 1" Hole Saw

### HARDWARE USED

**4x** 96-5013

- |  |                                 |
|--|---------------------------------|
|  | #90-011 Hex Bolt 5/16" x 1-3/4" |
|  | #98-122 Lock Washer             |
|  | #98-116 Flat Washer             |
|  | #98-157 Spacers                 |
|  | #94-132 5/16" Plusnut           |

**IMPORTANT:** After checking all bolts are tightened slide 8 partskeeper case to the cabinet.

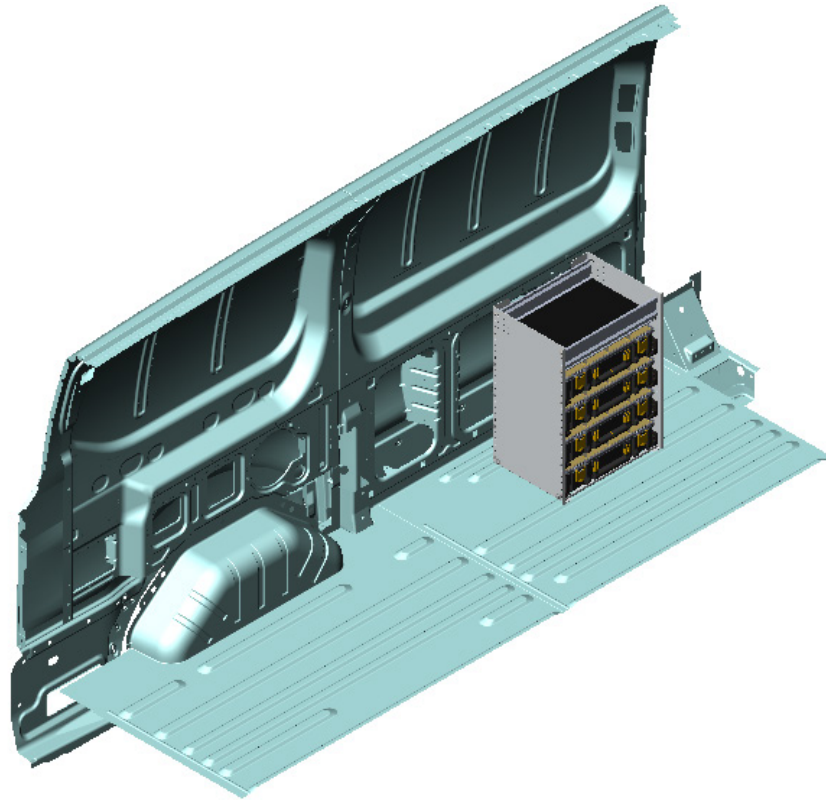

**“You have successfully installed your  
C2-PA18-4C**

**Thank you for doing business with us.”**

For any feedback or suggestions you may have, please contact: [cs@rangerdesign.com](mailto:cs@rangerdesign.com)

