

# Owner's Manual

## Carry Case Holder

This Owner's Manual provides assembly, install and user guidance. It applies to all **C5 Milwaukee Carry Case Holders** sold by Ranger Design. For a list of compatible models, visit our website at [rangerdesign.com](http://rangerdesign.com).

### Contents

Warnings.....	<b>2</b>
Parts Included.....	<b>3</b>
Tools Required (Not Included) .....	<b>4</b>
Assembly .....	<b>5</b>
Installation.....	<b>9</b>
Plusnut Guidelines ..	<b>11</b>

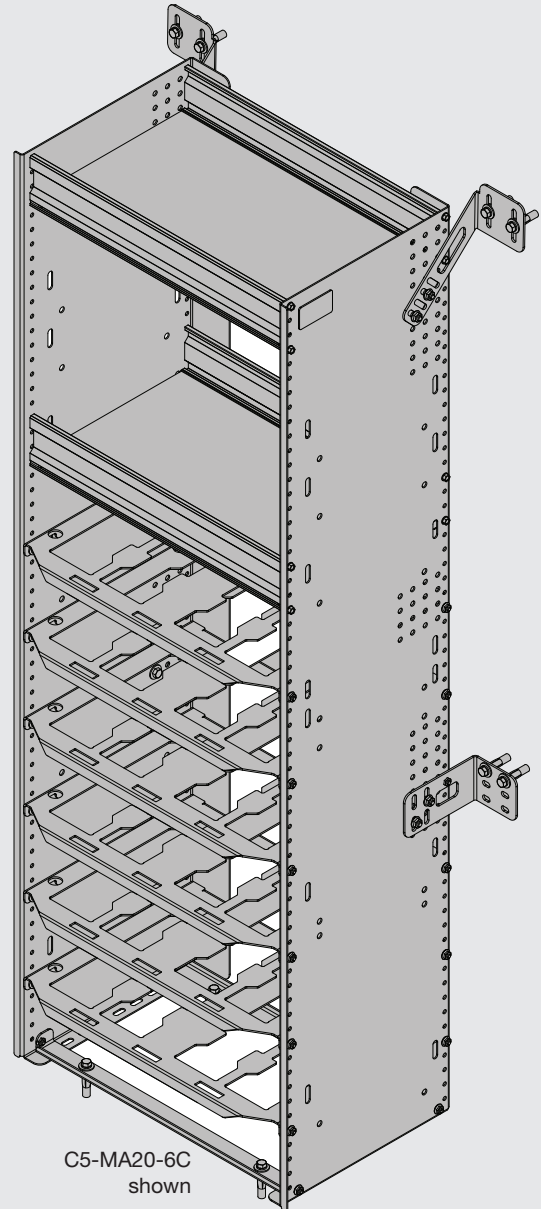

A Clariance Technologies Company

Scan the QR code for the latest Installation Guide. For more information, visit [rangerdesign.com](http://rangerdesign.com).



# Warnings

READ, UNDERSTAND, AND FOLLOW ALL WARNINGS AND INSTRUCTIONS BEFORE USING THIS PRODUCT. FAILURE TO FOLLOW THESE DIRECTIONS MAY RESULT IN PROPERTY DAMAGE, SERIOUS BODILY INJURY, AND/OR DEATH. RANGER DESIGN IS NOT RESPONSIBLE FOR ANY PROPERTY DAMAGE, PERSONAL INJURY, OR DEATH THAT OCCURS WHILE USING ANY RANGER DESIGN PRODUCTS.

THE FINAL ALTERER AND/OR MODIFIER SHOULD REVIEW THE WARNING SHEET WITH THE CUSTOMER BEFORE THE VEHICLE IS RELEASED TO THE CUSTOMER FOR GENERAL USE. THESE INSTRUCTIONS SHOULD REMAIN WITH THE VEHICLE AT ALL TIMES.

## WARNINGS – Prior To Starting

- Ranger Design products must be assembled and installed by individuals qualified to use the tools required and have experience with similar products. If there is any question as to competence or experience, please contact a professional alterer or modifier.
- Failure to use Ranger Design-provided fasteners, brackets, and proper installation guidelines could increase risk of serious personal injury and/or death.
- Prior to installation, inspect the vehicle to ensure that installation will not interfere with, or cause obstruction of, any critical components such as electrical wiring, fuel tanks, fuel cells, locks, latches, etc.
- The final alterer and/or modifier is responsible for ensuring all equipment is sufficiently secured to wall and floor structures or suitable anchorages.
- Do not install systems into any weak or unsound materials such as plastics, woods, thin-walled metals, etc., without proper reinforcement.
- Do not install this product where it could interfere with the deployment of airbags. Failure to comply could result in death or serious injury.
- Do not install this product where it could ingress on the Vehicle Occupant Protection Zone. Failure to comply could result in death or serious injury.
- Incorrect installation could cause water leaks, electric shock, or fire.
- Any cargo vehicle with any cargo or equipment should use a certified partition which can be found on the Ranger Design website. (<https://rangerdesign.com>)
- Mounting rails and floors are strongly recommended for any attachment to the vehicle and can be found on the Ranger Design website. (<https://rangerdesign.com>)
- Any modification or unintended use of this product voids any warranty and could create a hazardous condition.
- Ranger Design provides recommended assembly and installation instructions which must be followed to ensure correct operation. Failure to do so could invalidate the product's compliance and/or warranty and cause injury.
- The final stage vehicle alterer and/or modifier is responsible for the integration, installation, and compliance of the product in its final location with all applicable regulations and standards. Failure to maintain compliance of the vehicle with applicable regulations and standards could be punishable by law. Alterers and/or modifiers should consult with all local authorities prior to commissioning.

- Any materials, padding, or glazing installed in the vehicle must comply with FMVSS/CMVSS 201/205/302, as applicable.

## WARNINGS – Prior To Drilling

- Improper drilling can cause property damage to vehicles and could lead to electric shock, fire, or even death.
- Ensure that drilling is only performed on areas of the vehicle allowed by the vehicle's Original Equipment Manufacturer's Body Builders Layout Book (or equivalent document).
- Ensure that you will not hit any critical parts of the vehicle like the gas tank, wiring harnesses, or hoses. Consult the vehicle's OEM documentation as necessary. When drilling, use a drill collar to reduce the risk of damage to the vehicle.

## WARNINGS – Prior To Operating Vehicle

- The heaviest items must be placed towards the bottom of the vehicle, while the lightest ones can be arranged upwards. Vehicle cargo loading weight proportion should follow the guidelines shown here.
- Check your vehicle's tare weight and remaining load capacity with all equipment installed. Never exceed the maximum Gross Vehicle Weight Rating (GVWR), Gross Axle Weight Ratings (GAWRs), or other maximum loads permitted by the vehicle's Original Equipment Manufacturer (OEM) and required by law.
- All items in the cargo area should be properly secured and partition doors closed while the vehicle is in motion.
- All system components should be regularly inspected, cleaned, and maintained pursuant to Ranger Design guidelines.

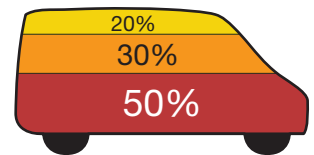

## WARNING – In Event Of An Accident

- In the event of a motor vehicle accident or collision where a Ranger Design system has been installed, especially ones where the vehicle's structure has been damaged and/or the air bags have deployed and/or the vehicle has been towed, the system must be inspected to ensure continued soundness and safety before returning the vehicle to service. Damaged components should be replaced as necessary.

 **FR:** Si vous avez besoin de ces instructions en français, s'il vous plait contacter notre service à la clientèle. +1-800-565-5321

 **ES:** Si necesita estas instrucciones en español, comuníquese con el Servicio de atención al cliente de Ranger Design. +1-800-565-5321

# Parts Included

**Top Composite Shelf Tray** – Qty. 2  
P/N L4-11.875 x 20.5

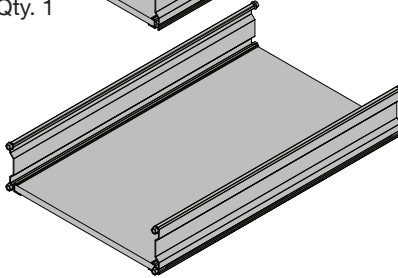
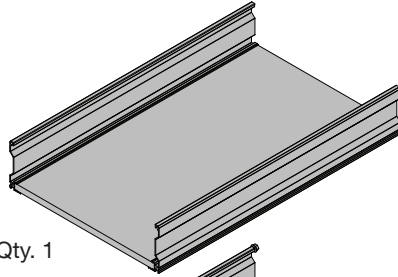

**N5 Bracket Right** – Qty. 1  
P/N 40-750

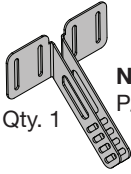

**N5 Bracket Left** – Qty. 1  
P/N 40-751

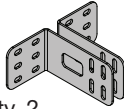

**Middle Bracket** – Qty. 2  
P/N 84-012

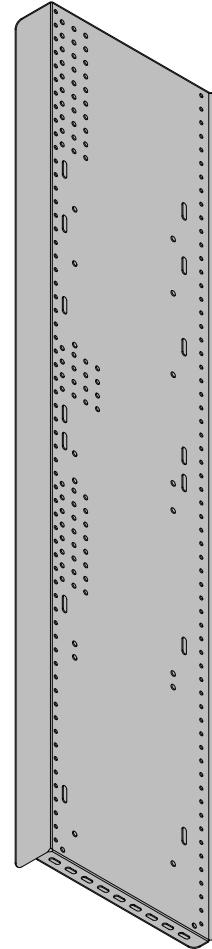

**C5 End Panel Right** – Qty. 1  
P/N 40-745

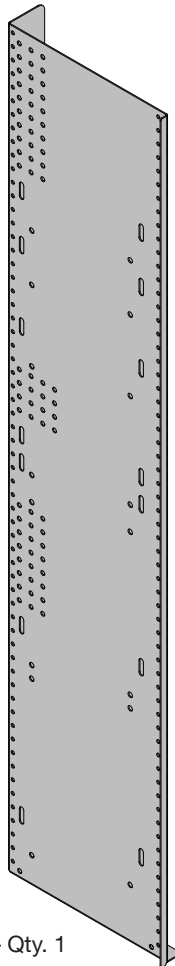

**C5 End Panel Left** – Qty. 1  
P/N 40-744

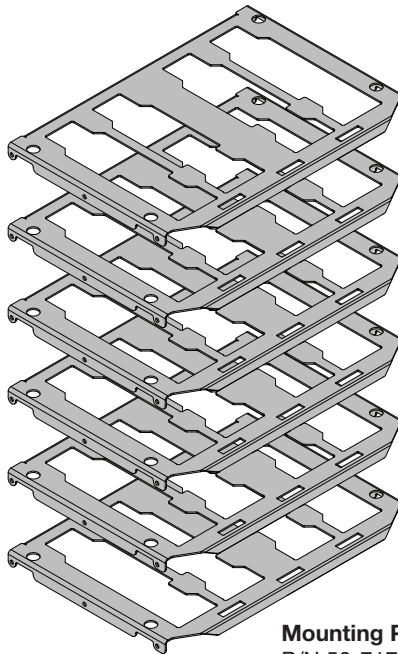



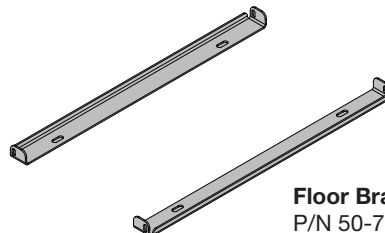



**Mounting Plate** – Qty. 6  
P/N 50-717



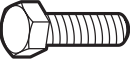



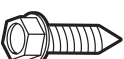

**Floor Bracket** – Qty. 2  
P/N 50-716

# Parts Included

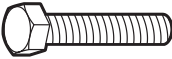
## Assembly Fastener Kit Content

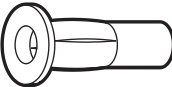
Part	P/N & Description	P/N 94-5028 Qty.
	<b>P/N 90-108</b> Hex Bolt 1/4"-20 x 1/2" ZINC	<b>28</b>
	<b>P/N 92-204</b> Hex Bolt 5/16"-18 x 3/4" GR-5 ZINC	<b>8</b>
	<b>P/N 94-112</b> Serrated Nut 1/4"-20 ZINC	<b>28</b>
	<b>P/N 94-116</b> Serrated Nut 5/16"-20 ZINC	<b>8</b>
	<b>P/N 98-112</b> Flat Washer 1/4" ZINC	<b>28</b>
	<b>P/N 98-116</b> Flat Washer 5/16" ZINC	<b>8</b>
	<b>P/N 92-102</b> Screw HWH #14 x 1" ZINC	<b>16</b>

## Installation Fastener Kit Content

Part	P/N & Description	P/N 96-5023 Qty.
	<b>P/N 90-011</b> Hex Bolt 5/16"-18 x 1-3/4" GR-5 ZINC	<b>4</b>
	<b>P/N 90-212</b> Hex Bolt 5/16"-18 x 1-1/4" GR-5 ZINC	<b>8</b>
	<b>P/N 94-132</b> Plusnut 5/16"	<b>12</b>
	<b>P/N 98-116</b> Flat Washer 5/16", O.D. 7/8" ZINC	<b>12</b>
	<b>P/N 98-122</b> Lock Washer 5/16" ZINC	<b>12</b>
	<b>P/N 98-157</b> Spacer 0.375" ID x 1.0" OD x 0.25" LONG NYLON	<b>4</b>

# Tools Required (Not Included)

- Cordless Impact Driver
- Cordless Drill
- Tape Measure
- Marker
- 1/2" Socket
- 7/16 Socket
- 1/2" Drill Bit w/ Drill Collar (Set at 1/2")
- 3/8" Driver Bit
- Plusnut Tool / Plusnut Gun ( 5/16" )
- 7/16" Drill Bit

# Assembly

## NOTE:

- Each shelf & mounting plate supports up to **55 lbs.** The maximum total load capacity for the entire unit is **250 lbs.**

## STEP 1 Installation reference for shelf and tray positions.

### BEFORE STARTING

- Place end panels on clean, flat surface on their back sides.

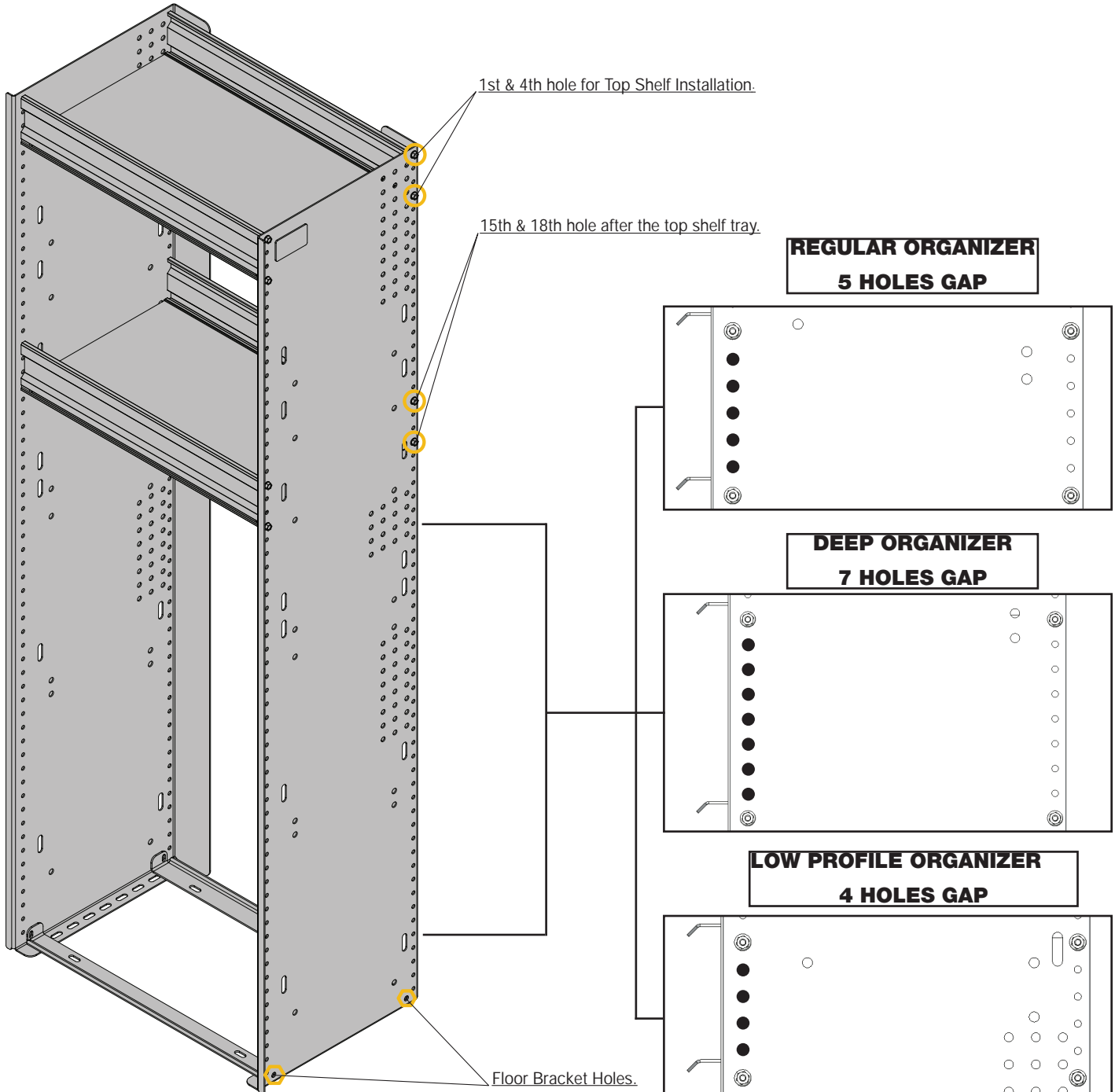

# Assembly

## STEP 2 Attach shelf tray, mounting plate and floor bracket to the left end panel.

### NOTE:

- Before installing the mounting plate refer to step 1 for the spacing of the Milwaukee organizer (Regular, Deep, or Low-profile).

### NOTE:

This install features Regular Milwaukee organizer 5 holes gap.

### TOOLS

- Impact Driver
- 7/16" Socket
- 3/8" Socket

### HARDWARE

Hex Bolt 1/4" x 5/8" Qty: 14  
Flat Washer 1/4" Qty: 14

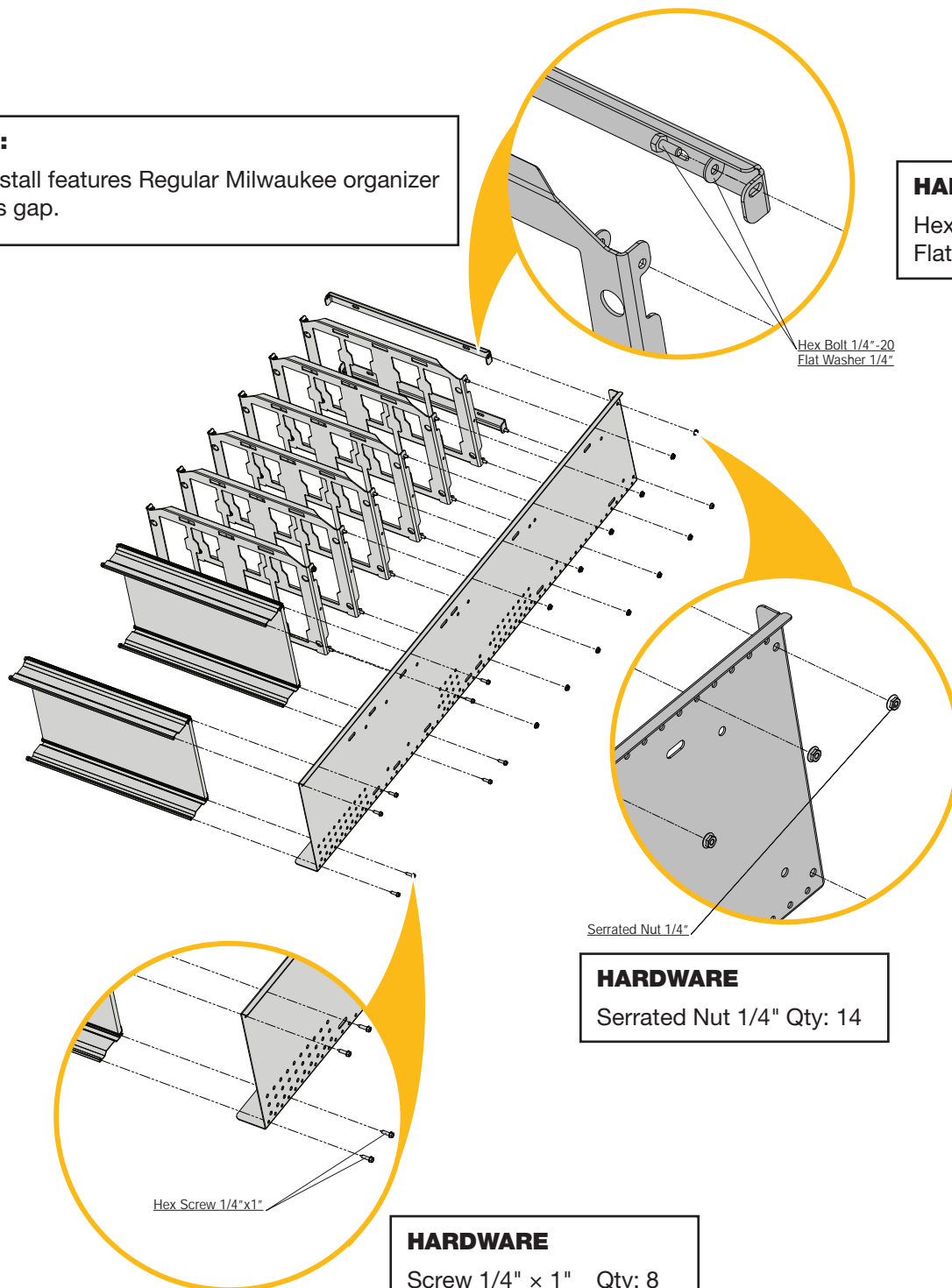

### HARDWARE

Serrated Nut 1/4" Qty: 14

### HARDWARE

Screw 1/4" x 1" Qty: 8



Torque to  
8 ft-lbs.

# Assembly

**STEP 3** Attach the right end panel to the shelf tray, mounting plate, and floor brackets using the hardware provided on the opposite side.

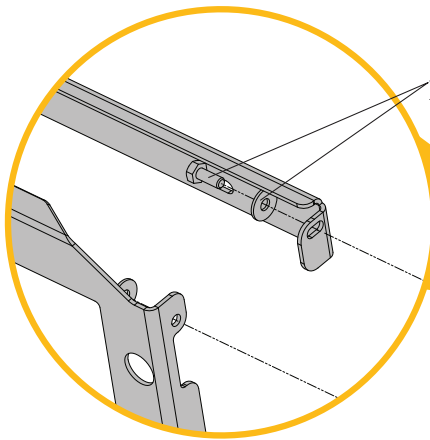

Hex Bolt 1/4"-20  
Flat Washer 1/4"

## HARDWARE

Hex Bolt 1/4" x 5/8" Qty: 14  
Flat Washer 1/4" Qty: 14

## TOOLS

- Impact Driver
- 7/16" Socket
- 3/8" Socket

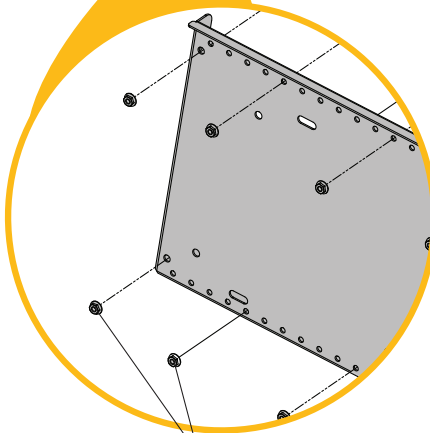
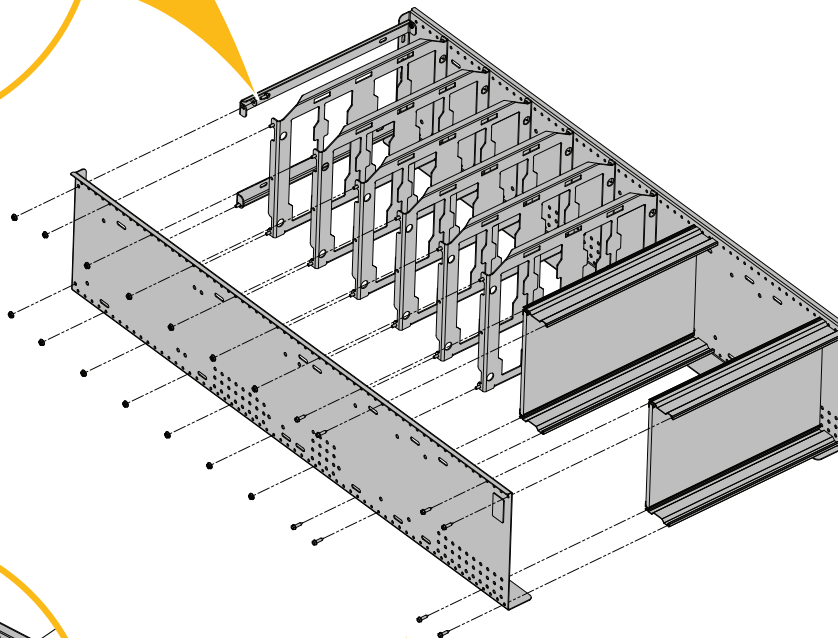

Serrated Nut 1/4"

## HARDWARE

Serrated Nut 1/4" Qty: 14

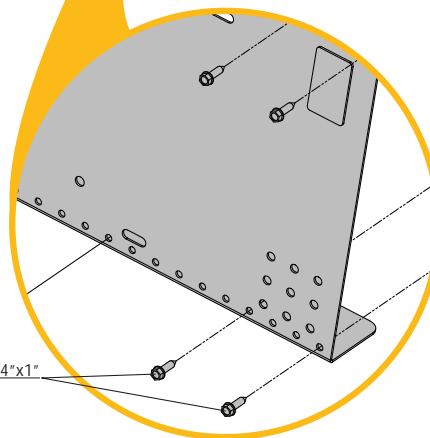

Hex Screw 1/4" x 1"

## HARDWARE

Screw 1/4" x 1" Qty: 8



Torque to  
8 ft-lbs.

# Assembly

**STEP 4** Install brackets to side panels using provided hardware.

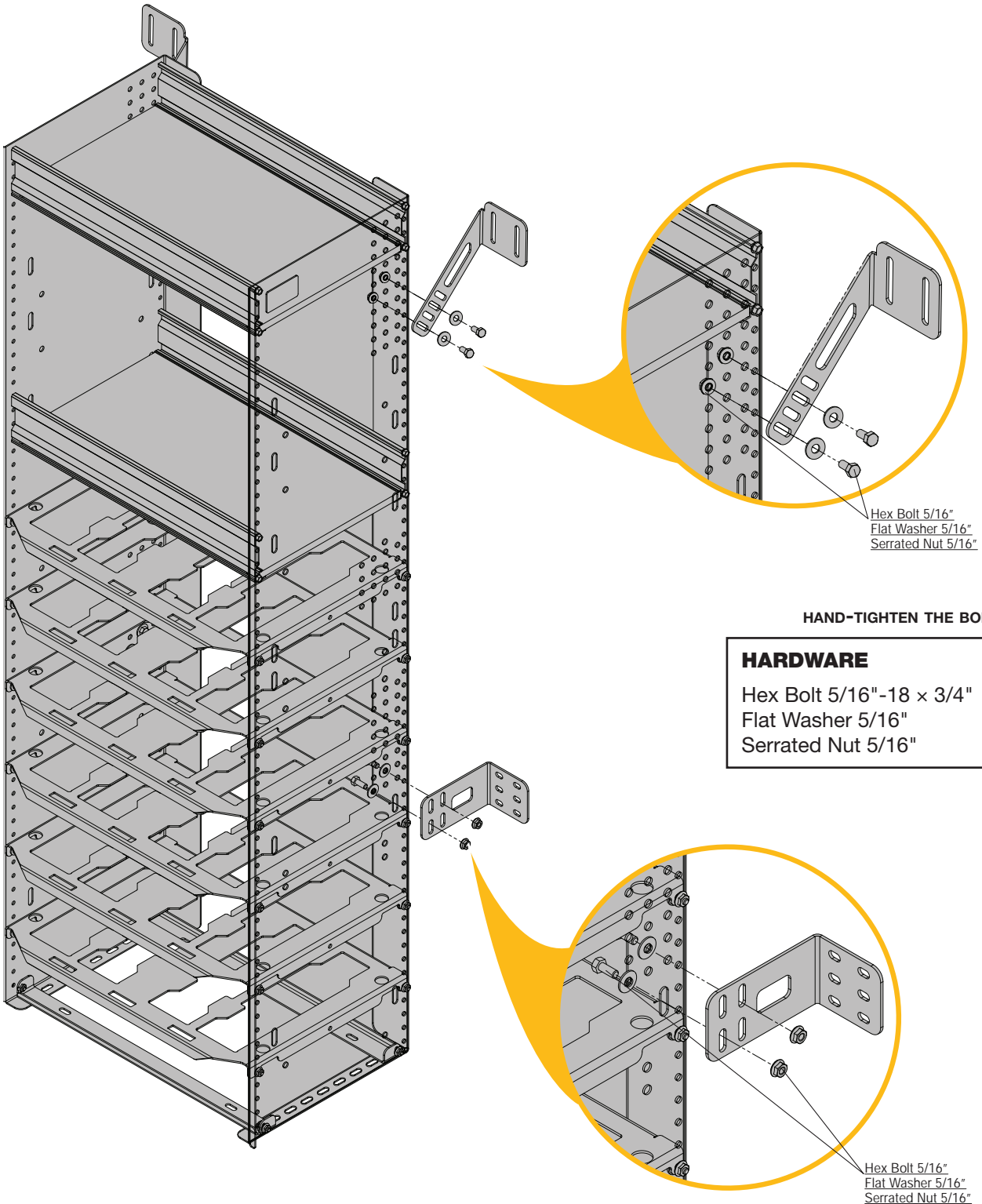

# Installation



**WARNING:** Ensure case holder is sufficiently secured based on expected vehicle use.

- More attachment points improve retention and rigidity of case holder.
- It is recommended to use **Ranger Design mounting track** and **floor** to ease installation and better distribute shelf load.

## STEP 5 Mark van wall and van floor for plusnut and wood insert installation.

### NOTE:

\*When attaching to a:

**Ranger Design mounting track**, refer to the applicable mounting track instructions.

**Non-Ranger Design mounting track**, refer to the mounting track manufacturer's mounting instructions.

Sheet metal wall, refer to **Plusnut Guidelines** on page 11.

- With 2 people, place the case holder in its final position on the floor of the vehicle.
- Line up brackets, mid brackets and floor brackets to location and mark hole locations.

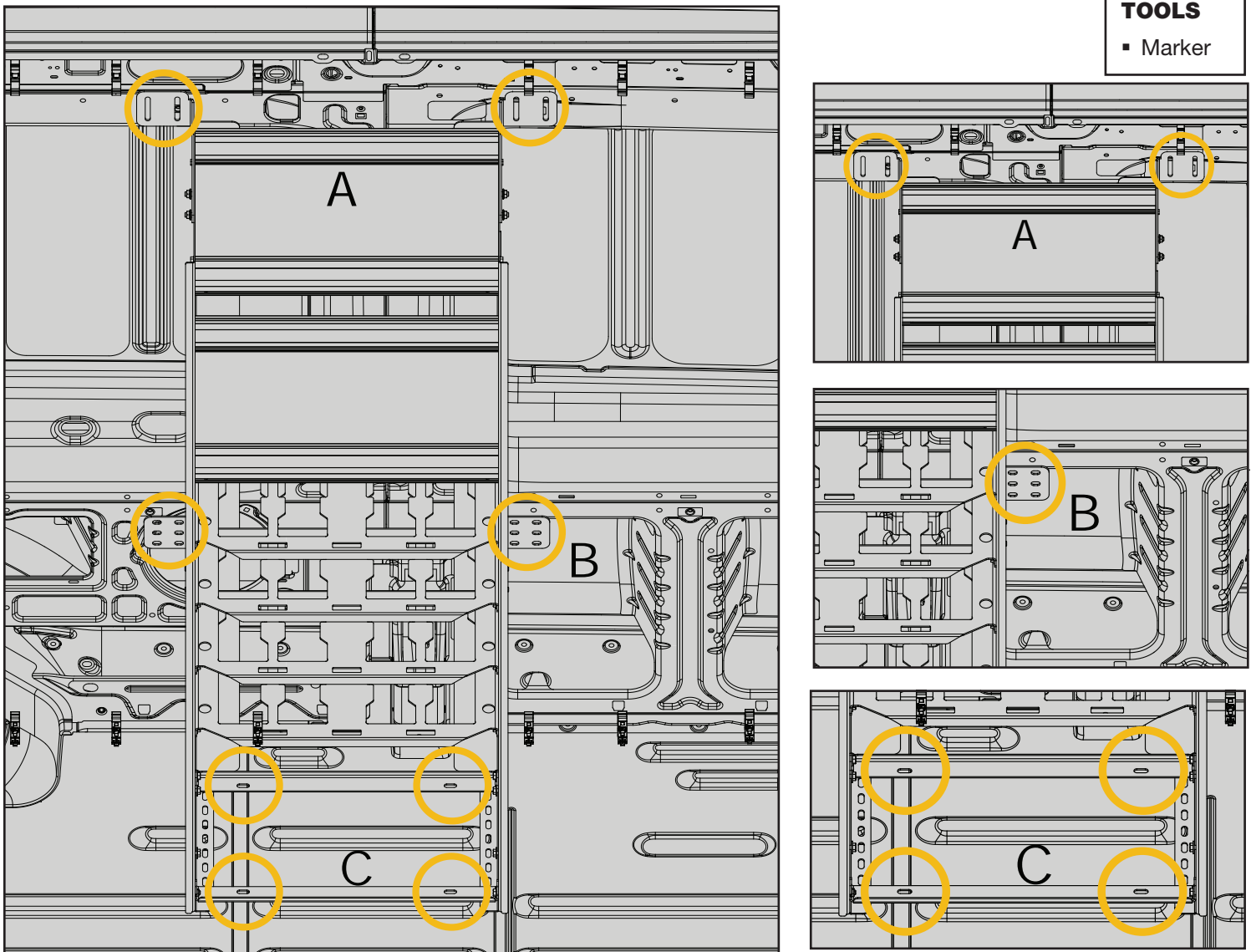

# Installation

## STEP 6 Install plusnuts on van wall and floor using provided hardware.

### NOTE:

\*When attaching to a:

- **Ranger Design E-Floor or Track floor**, refer to applicable Ranger Design floor install instructions.
- **Non-Ranger Design Floor**, refer to applicable non-Ranger Design floor install instructions.
- Sheet metal floor, refer to **Plusnut Guidelines** on page 11.

### TOOLS

- Impact Driver
- 1/2" Socket

### HARDWARE

Hex Bolt 5/16"-18 x 1-1/4"	Qty: 8
Lock Washer 5/16"	Qty: 8
Flat Washer 5/16"	Qty: 8

### HARDWARE

Hex Bolt 5/16"-18 x 1-3/4"	Qty: 4
Lock Washer 5/16"	Qty: 4
Flat Washer 5/16"	Qty: 4
Nylon Spacer	Qty: 4

Hex Bolt 5/16" x 1-3/4"  
Lock Washer 5/16"  
Flat Washer 5/16"

Nylon Spacer



**Torque to  
12 ft-lbs.**

# Plusnut Guidelines



**CAUTION:** When drilling into sheet metal be sure to:

- Follow OEM-provided no-drill-zone guidelines.
- Rust protect all holes after drilling.

## When attaching to sheet metal using plusnuts:

- Use plusnuts and fasteners provided in installation fastener kit and refer to the **Ranger Design Plusnut Installation Instructions** found in plusnut tool package.
- Follow the specific manufacturer's install guidelines if using alternative attachments to sheet metal.
- Use spacers provided in installation fastener kit when attaching shelf to an uneven sheet metal floor.
- Ensure plusnuts on the bracket are installed diagonally from each other and as far apart as possible.

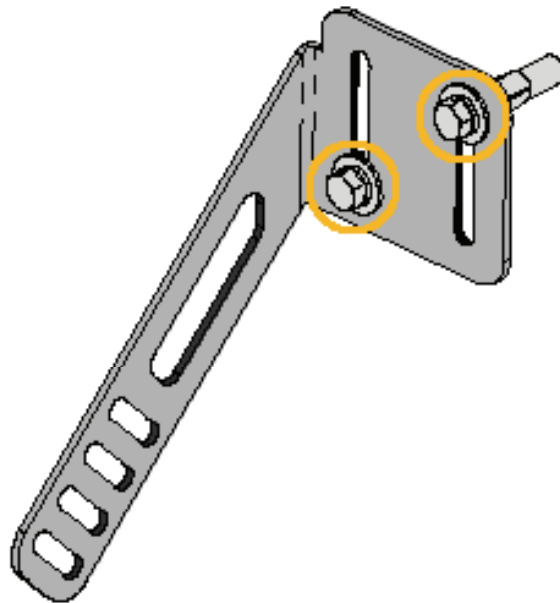



A Clarience Technologies Company

**You have successfully assembled and installed your Milwaukee Carry Case Holder.**

**Thank you for doing business with us.**

**For technical support, contact us at 1-800-565-5321.**

**For any feedback or suggestions you may have, please contact [cs@rangerdesign.com](mailto:cs@rangerdesign.com).**

Copyright © 2024

All rights reserved. This manual or any portion thereof may not be reproduced or used in any manner whatsoever without the express written permission of Ranger Design, Inc.