

# INSTALLATION GUIDE

# SET-UP - PARTS & TOOLS



## Access Stow Single Rail Kit 19-U0001



Scan the QR code for latest Install-Guide.



Rev A5

### 19-U0001 BOX

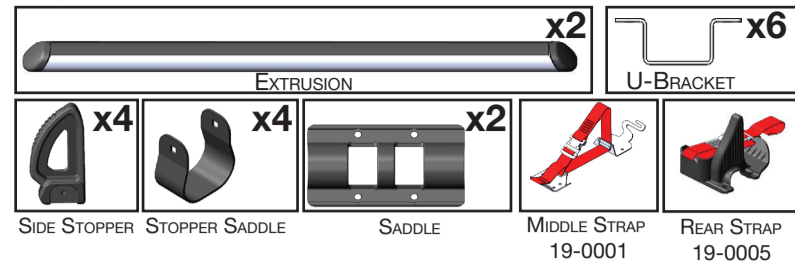

### Anti-Theft

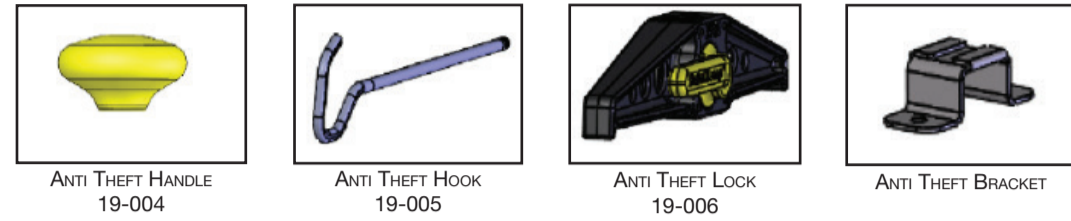

### Hardware

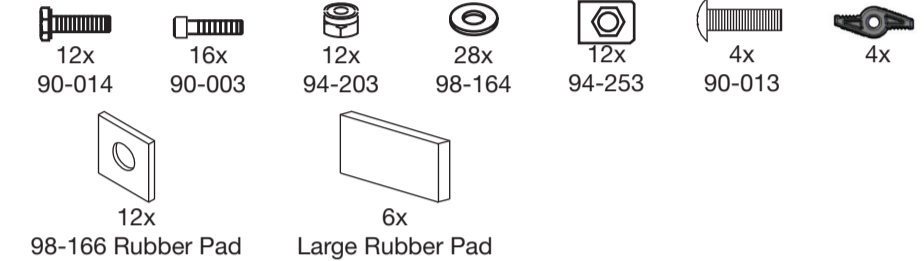

## INSTALL PREPARATION

### REQUIRED ITEMS

- Ladder
- 13mm Wrench
- Allen key (from 19-U0003)

1 PERSON



Lay the assembled 19-U0003 unit facing up.

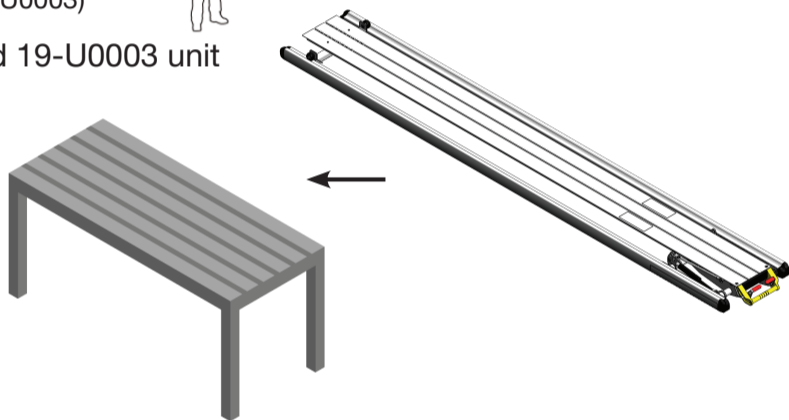

## STEP 1 - SIDE STOPPER ASSEMBLY

\*For width and placement adjustments, see Step 7.

**A.** Place stopper saddles on both ends of the extrusions.

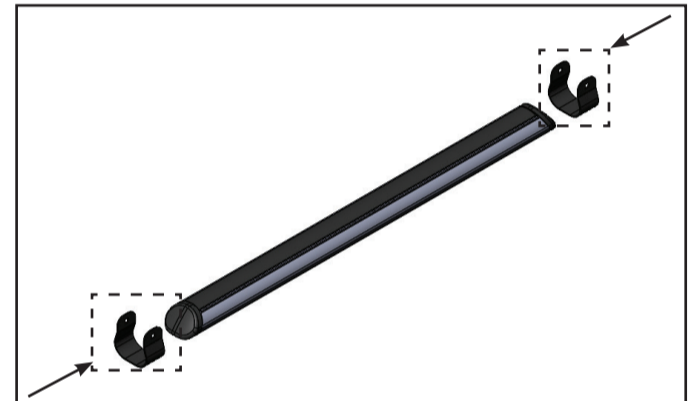

**B.** Attach the stoppers to saddles.

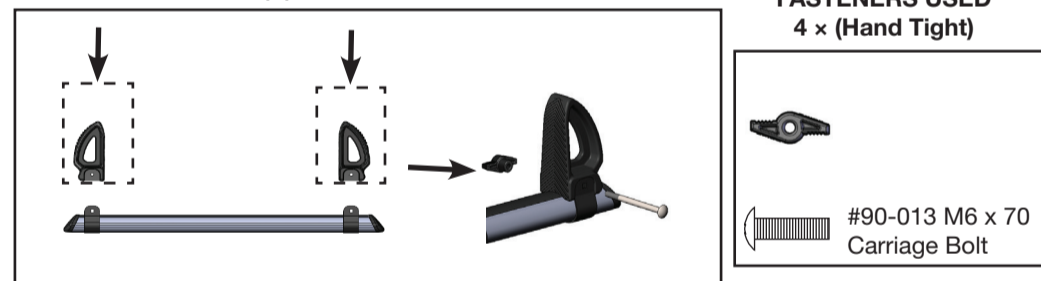

**C.** Repeat steps A and B for second extrusion.

## STEP 2 - FRONT SADDLE INSTALLATION

Move sliders as needed. Fasten extrusion with saddle.

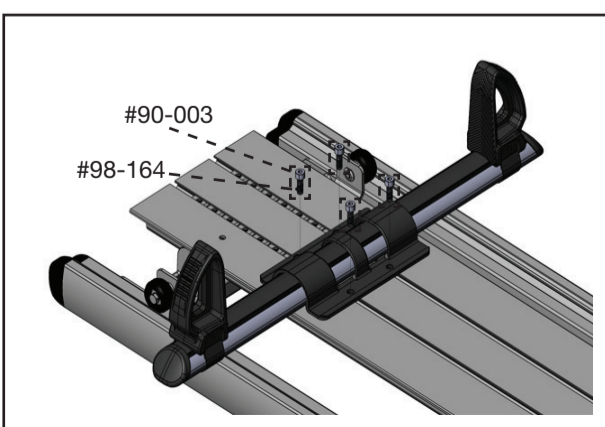
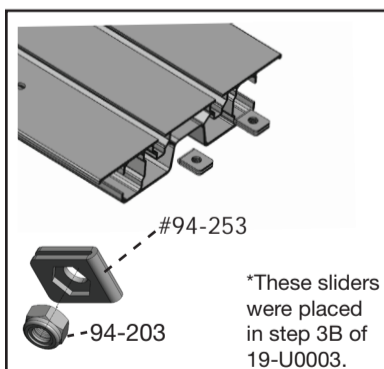

**FASTENERS USED**  
4 x (12 ft • lbs)

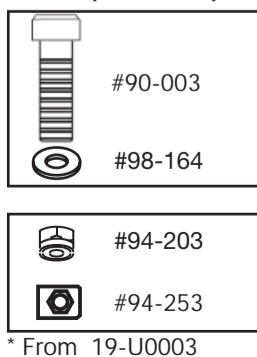

## STEP 3 - MID-STRAP & ANTI THEFT BRACKET INSTALLATION

Move sliders as needed. Fasten middle strap.

\*For placement, see Step 7.

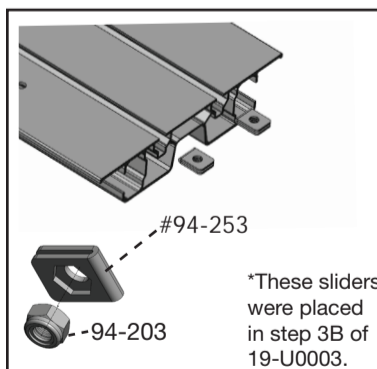

**FASTENERS USED**  
8 x (12 ft • lbs)

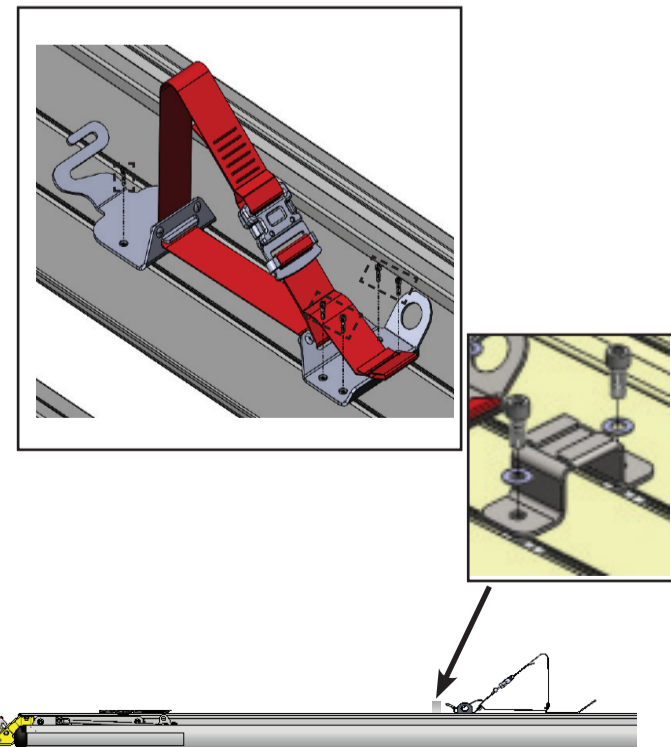
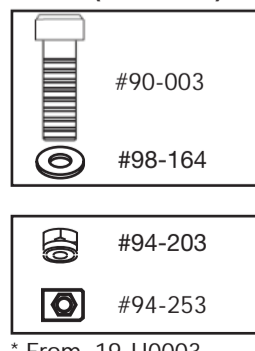

## STEP 4 - REAR SADDLE AND STRAP ASSEMBLY

**A.** Place second extrusion and rear saddle at required spot.

\*For placement, see Step 7.

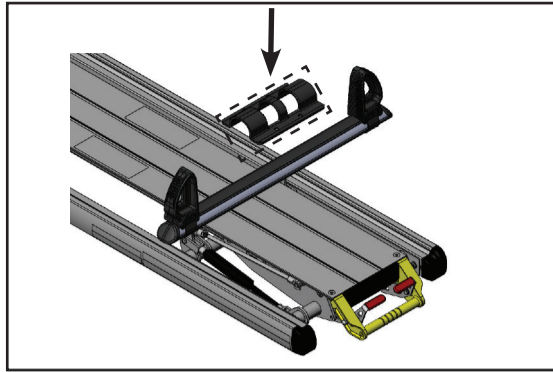

**B.** Place rear strap on top of the saddle.

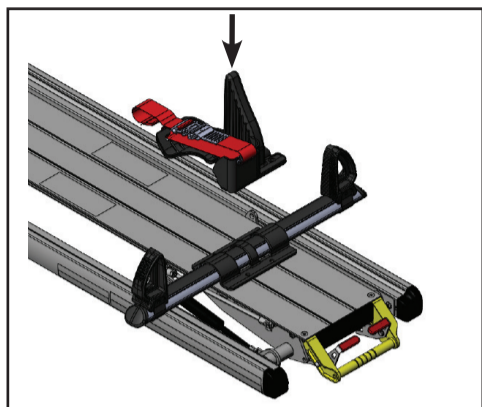

## STEP 5 - REAR SADDLE AND STRAP INSTALLATION

Move sliders as needed. Fasten saddle and strap.

\*The rear saddle and strap assembly must not pass the gas shock mechanism underneath. See red dashed line in Step 7 for placement.

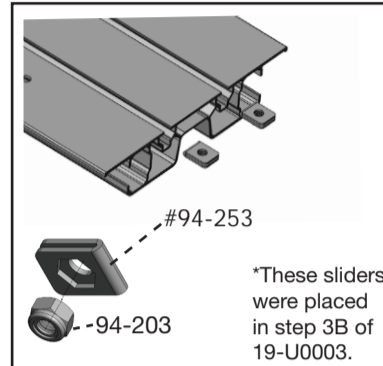
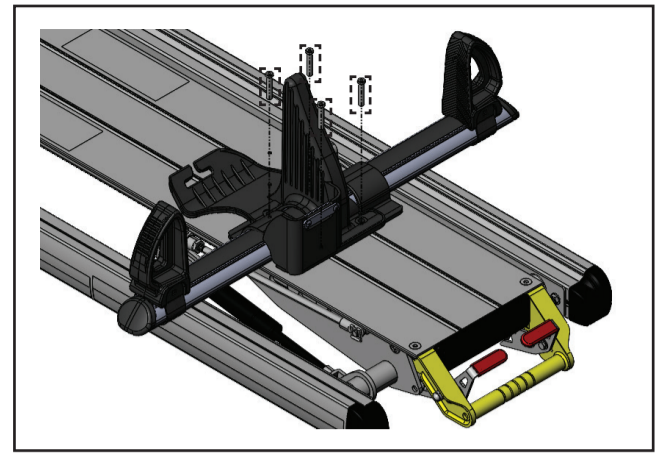

**FASTENERS USED**  
4x (12 ft • lbs)

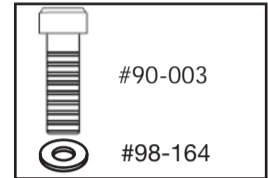

\*From 19-U0003

## CROSSBAR PLACEMENT REFERENCE

Place crossbars as shown. For side to side alignment, see 16-UCD72 IG. Scan the QR for latest IG.

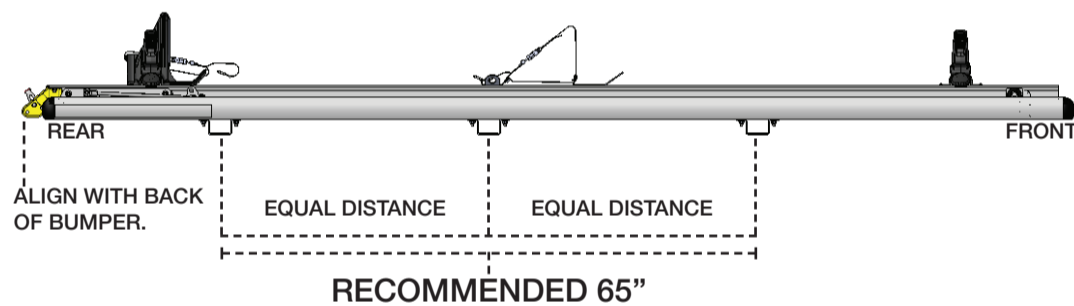

## STEP 6 - U-BRACKET ASSEMBLY AND INSTALLATION

Insert 90-825 bolt into 94-253 and slide down rails. Space according to foot placement. Fasten access stow to 16-UCD72 and 16-UCS72 crossbars using U-brackets. Add rubber pads between extrusion and U-brackets as shown.

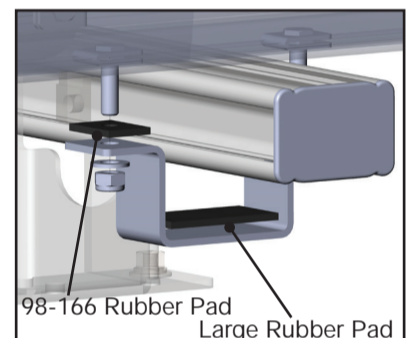
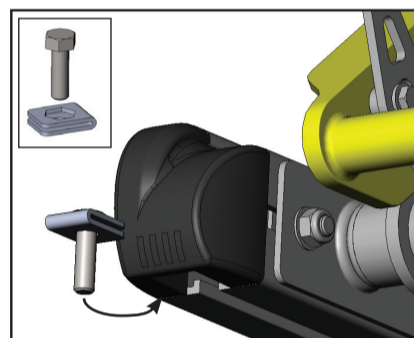

**FASTENERS USED**  
12 x (12 ft • lbs)

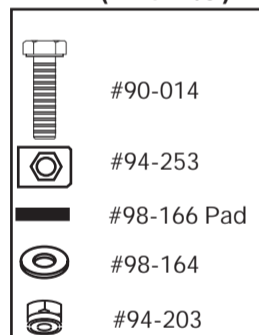

## STEP 7 - LADDER RESTRAINT ADJUSTMENT

Adjust side stoppers to accommodate ladder width, then hand tighten. Stoppers should be equally spaced. Repeat for both front and rear saddle assemblies.

Adjust to ladder width

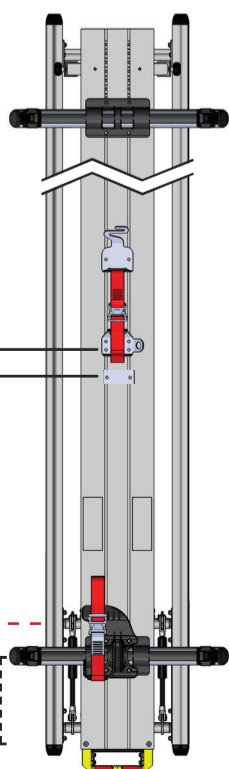
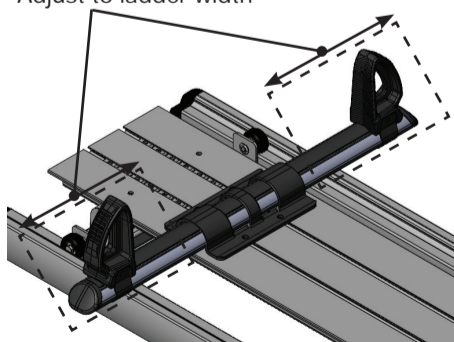

Ensure strap is reachable from ground when ladder rack is deployed.

MIN. 47" Ensure bracket is reachable from ground when ladder rack is deployed.

MIN. 6" Ladder must avoid ground. Do not pass gas-shocks.

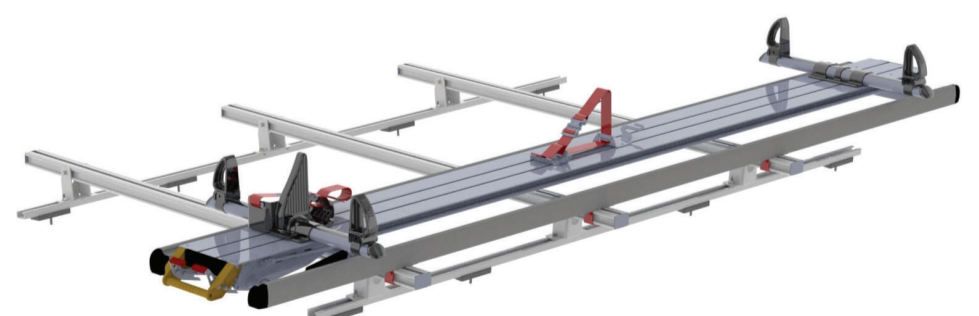

**"You have successfully installed your Access Stow, thank you for doing business with us."**

For any feedback or suggestions, you may have, please contact: [cs@rangerdesign.com](mailto:cs@rangerdesign.com)



# BEFORE YOU BEGIN

READ, UNDERSTAND, AND FOLLOW ALL WARNINGS AND INSTRUCTIONS BEFORE USING THIS PRODUCT. FAILURE TO FOLLOW THESE DIRECTIONS MAY RESULT IN PROPERTY DAMAGE, SERIOUS BODILY INJURY, AND/OR DEATH. RANGER DESIGN IS NOT RESPONSIBLE FOR ANY PROPERTY DAMAGE, PERSONAL INJURY, OR DEATH THAT OCCURRED WHILE USING ANY RANGER DESIGN PRODUCTS.



## WARNING

- Failure to use Ranger Design-provided fasteners, brackets, and proper installation guidelines could increase risk of serious personal injury and/or death.
- If drilling is required to complete this installation: improper drilling can cause property damage to vehicles and could lead to electric shock, fire, or even death.
- If drilling is required to complete this installation: Ensure that drilling is only performed on areas of the vehicle allowed by the vehicle's Original Equipment Manufacturer's Body Builders Layout Book (or equivalent document).
- Prior to installation, inspect the vehicle to ensure that installation will not interfere with, or cause obstruction of, any critical components such as electrical wiring, fuel tanks, fuel-cells, locks, latches, etc.
- The installer or manufacturer is responsible for ensuring anchorages are installed onto suitable wall and floor structures; wall and floor strength must meet applicable performance requirements.
- Do not install systems into any weak or unsound materials such as plastics, woods, thin-walled metals, etc. without proper reinforcement.
- Do not install this product where it could interfere with the deployment of airbags. Failure to comply could result in death or serious injury.
- Incorrect installation could cause water leaks, electric shock or fire.
- Any cargo vehicle with any cargo or equipment should use a certified partition. See Ranger Design website for some partition options. (<https://rangerdesign.com/>)
- Mountings rails are recommended for any attachment to the vehicle walls.
- All items in the cargo area should be properly secured and partition doors closed while the vehicle is in motion.
- Check your vehicle's tare weight and remaining load capacity with all the equipment installed. Never exceed the maximum Gross Vehicle Weight Rating (GVWR), Gross Axle Weight Ratings (GAWRs), or other maximum loads permitted by the vehicle's Original Equipment Manufacturer (OEM) and required by law.
- The heaviest items must be placed towards the bottom of the vehicle, while the lightest ones can be arranged upwards. Vehicle cargo loading weight proportion should follow the following guidelines:

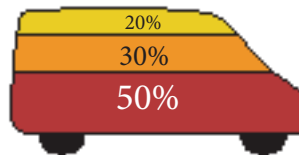

- The final alterer and/ or modifier should review the warning sheet with the customer before the vehicle is released to the customer or for general use. These instructions should remain with the vehicles a all times.
- Any modification or unintended use of this product voids any warranty and could create a hazardous condition.
- Ranger Design provides recommended assembly and installation instructions which should be followed to ensure correct operation. Failure to do so could result in invalidating the product's compliance, warranty and cause injury. Notwithstanding, the final stage vehicle alterer and/or modifier is responsible for the integration, installation, and compliance of the product in its final location to all applicable regulations and standards. Failure to maintain compliance of the vehicle to applicable regulations and standards could be punishable by law. Alterers and/or modifiers should consult with all local authorities prior to commissioning.



## CAUTION

- If drilling is required to complete this installation. Before drilling, ensure that you will not hit any critical parts of the vehicle like the gas tank, wiring harness, or hose. Consult the vehicle OEM documentation as necessary. When drilling, use a drill collar to reduce the risk of damage to the vehicle.
- Any materials, padding, or glazing installed in the vehicle must comply with FMVSS/CMVSS 201/205/302, as applicable.
- In the event of a motor vehicle accident or collision where a Ranger Design system has been installed, especially ones where the vehicle structure is damaged and/or the air bags deploy and/or the vehicle has been towed, the system must be inspected to ensure continued soundness and safety before returning the vehicle to service. Damaged components should be replaced as necessary.
- All system components should be regularly inspected, cleaned, and maintained pursuant to Ranger guidelines.