

Owner's Manual

RRB-Series

This Owner's Manual provides assembly, install and user guidance. It applies to all **RRB Truck Rack Series** sold by Ranger Design. For a list of compatible models, visit our website at rangerdesign.com.

Contents

Warnings	2
Parts Included	3
Tools Required	4
Assembly	5
Installation.....	13

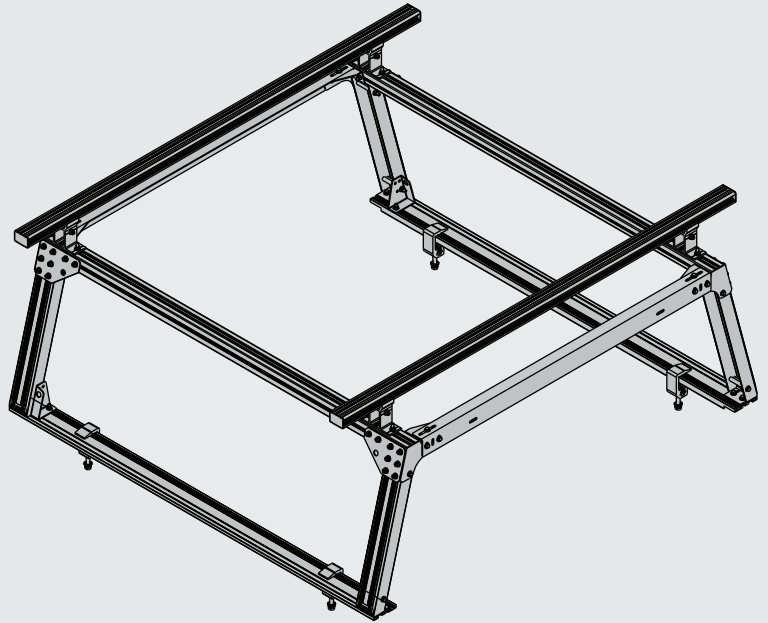

RRB-2055 shown



Scan the QR code for the latest Installation Guide. For more information, visit rangerdesign.com

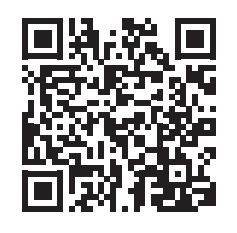

Warnings

READ, UNDERSTAND, AND FOLLOW ALL WARNINGS AND INSTRUCTIONS BEFORE USING THIS PRODUCT. FAILURE TO FOLLOW THESE DIRECTIONS MAY RESULT IN PROPERTY DAMAGE, SERIOUS BODILY INJURY, AND/OR DEATH. RANGER DESIGN IS NOT RESPONSIBLE FOR ANY PROPERTY DAMAGE, PERSONAL INJURY, OR DEATH THAT OCCURS WHILE USING ANY RANGER DESIGN PRODUCTS.

THE FINAL ALTERER AND/OR MODIFIER SHOULD REVIEW THE WARNING SHEET WITH THE CUSTOMER BEFORE THE VEHICLE IS RELEASED TO THE CUSTOMER FOR GENERAL USE. THESE INSTRUCTIONS SHOULD REMAIN WITH THE VEHICLE AT ALL TIMES.

WARNINGS – Prior To Starting

- Ranger Design products must be assembled and installed by individuals qualified to use the tools required and have experience with similar products. If there is any question as to competence or experience, please contact a professional alterer or modifier.
- Failure to use Ranger Design-provided fasteners, brackets, and proper installation guidelines could increase risk of serious personal injury and/or death.
- Prior to installation, inspect the vehicle to ensure that installation will not interfere with, or cause obstruction of, any critical components such as electrical wiring, fuel tanks, fuel cells, locks, latches, airbags, cameras, lights, sensors, mirrors, etc.
- The final alterer and/or modifier is responsible for ensuring all equipment is sufficiently secured to the vehicle.
- Do not install systems into any weak or unsound materials such as plastics, woods, thin-walled metals, etc., without proper reinforcement.
- Incorrect installation could cause water leaks, electric shock, or fire.
- Any modification or unintended use of this product voids any warranty and could create a hazardous condition.
- Ranger Design provides recommended assembly and installation instructions which must be followed to ensure correct operation. Failure to do so could invalidate the product's compliance and/or warranty and cause injury.
- The final stage vehicle alterer and/or modifier is responsible for the integration, installation, and compliance of the product in its final location with all applicable regulations and standards. Failure to maintain compliance of the vehicle with applicable regulations and standards could be punishable by law. Alterers and/or modifiers should consult with all local authorities prior to commissioning.

WARNINGS – Prior To Drilling

- Wherever possible, secure to existing Original Equipment Manufacturer's (OEM's) mounting points. Consults the vehicles OEM documentation for load limits of each attachment point.
- Improper drilling can cause property damage to vehicles and could lead to electric shock, fire, or even death.
- Ensure that drilling is only performed on areas of the vehicle allowed by the vehicle's OEM's Body Builders Layout Book (or equivalent document).

- Ensure that you will not hit any critical parts of the vehicle like the gas tank, wiring harnesses, or hoses. Consult the vehicle's OEM documentation as necessary. When drilling, use a drill collar to reduce the risk of damage to the vehicle.
- After drilling, ensure holes are sealed in accordance to the original vehicle manufacturer instructions.

WARNINGS – Prior To Operating Vehicle

- Ensure the weight of the cargo is correctly distributed to reduce negatively impacting the vehicle stability and handling. The heaviest items must be placed low in the vehicle, while the lighter items can be placed on a rack higher up.
- Operator must adapt speed to the conditions of the road, the wind, the weather, and the load being carried.
- Respect the maximum weight capacity of the Ranger product as defined in your operator's manual.
- Check your vehicle's tare weight and remaining load capacity with all equipment installed. Never exceed the maximum Gross Vehicle Weight Rating (GVWR), Gross Axle Weight Ratings (GAWRs), roof load limit, bed rail capacity, or other maximum loads permitted by the vehicle's Original Equipment Manufacturer (OEM) and required by law.
- All cargo should be properly secured while the vehicle is in motion.
- All system components should be regularly inspected for damage, corrosion, fractures, loose parts, loose fasteners, etc. pursuant to Ranger Design guidelines. Damaged components must be replaced and loose component tightened prior to operating the vehicle.
- All system components should be regularly cleaned and maintained pursuant to Ranger Design guidelines.

WARNING – In Event Of An Accident

- In the event of a motor vehicle accident or collision where a Ranger Design system has been installed, especially ones where the vehicle's structure has been damaged and/or the air bags have deployed and/or the vehicle has been towed, the system must be inspected to ensure continued soundness and safety before returning the vehicle to service. Damaged components should be replaced as necessary.

 **FR:** Si vous avez besoin de ces instructions en français, s'il vous plait contacter notre service à la clientèle. +1-800-565-5321





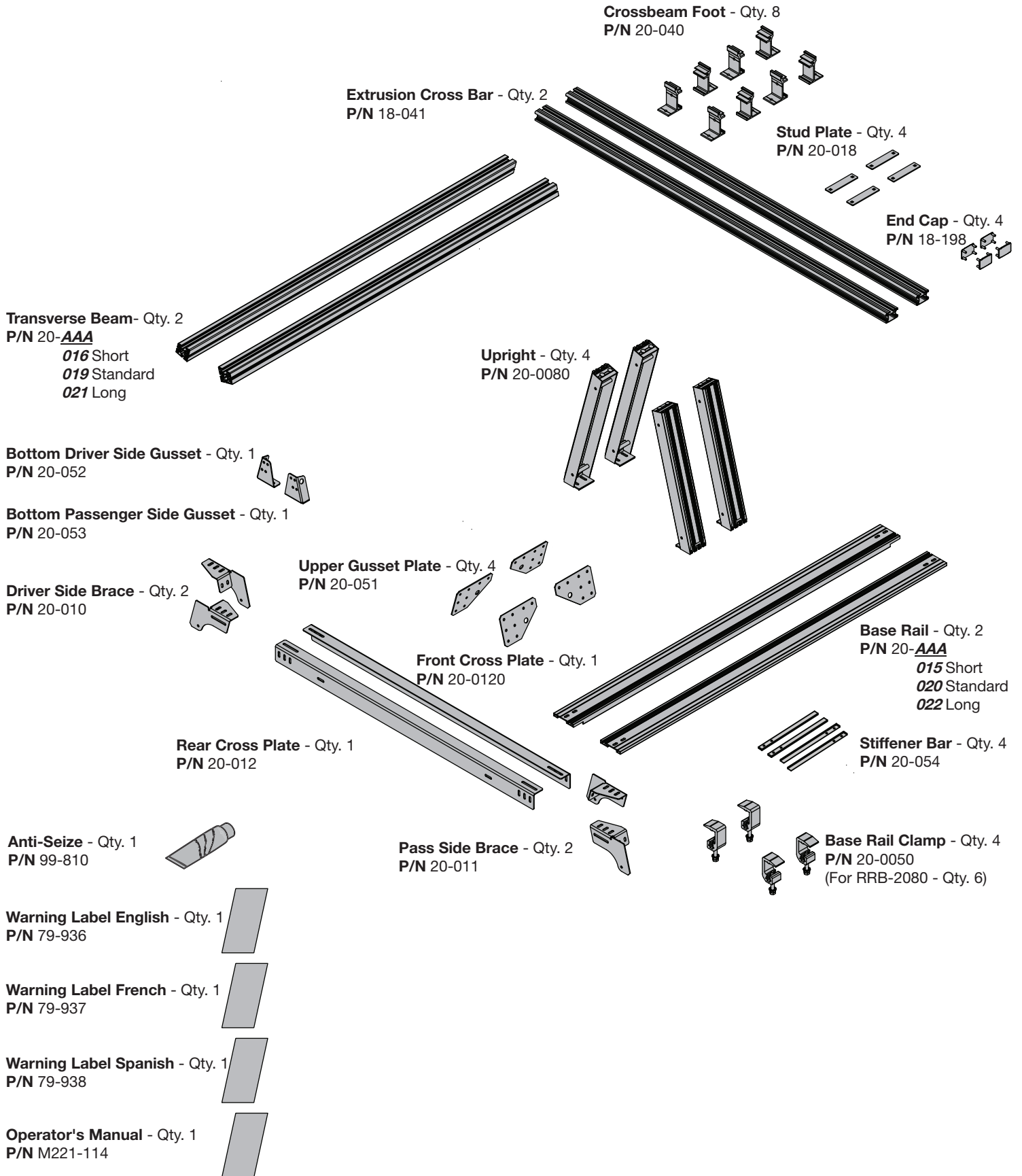

 **ES:** Si necesita estas instrucciones en español, comuníquese con el Servicio de atención al cliente de Ranger Design. +1-800-565-5321

Parts Included

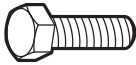





Parts Included

Installation Fastener Kit 96-2001 Content

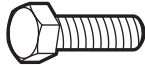
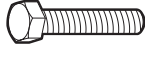
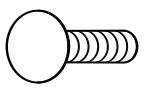
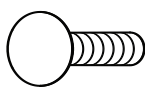
Part	P/N & Description	Qty.
	P/N 90-209 Hex Bolt 5/16"-18 x 1" SS 304	12
	P/N 90-237 Hex Bolt 5/16"-18 x 2-3/4" SS 304	4
	P/N 98-117 Flat Washer 5/16", O.D. 3/4" SST	40
	P/N 98-123 Washer Lock Spring 5/16" SST	8
	P/N 94-105 Hex Nut 5/16" - 18 SS 304	8
	P/N 94-111 Nut Lock Nylon SS 304	16

Assembly Fastener Kit 94-2001 Content

Part	P/N & Description	Qty.
	P/N 90-205 Bolt Carriage 5/16"-18 x 3/4" SS 304	24
	P/N 90-261 Hex Bolt 5/16"-18 x 4-1/4" SS 304	8
	P/N 90-491 Bolt Carriage 5/16- 18 x 1" SS 304	26
	P/N 90-499 Bolt Carriage 5/16- 18 x 1-1/2" SS 304	8
	P/N 98-117 Flat Washer 5/16", O.D. 3/4" SST	66
	P/N 98-123 Washer Lock Spring 5/16" SST	40
	P/N 94-105 Hex Nut 5/16"- 18 SS 304	32
	P/N 94-111 Nut Lock Nylon SS 304	18

Tools Required (Not Included)

- Ratchet
- 1/2" Socket
- 3/4"Socket
- Rubber Mallet
- 1/2" Wrench

Assembly

STEP 1 Assemble uprights to base rail. Ensure uprights are flush to the ends and tighten in place. See **Vehicle Chart** below for positioning.

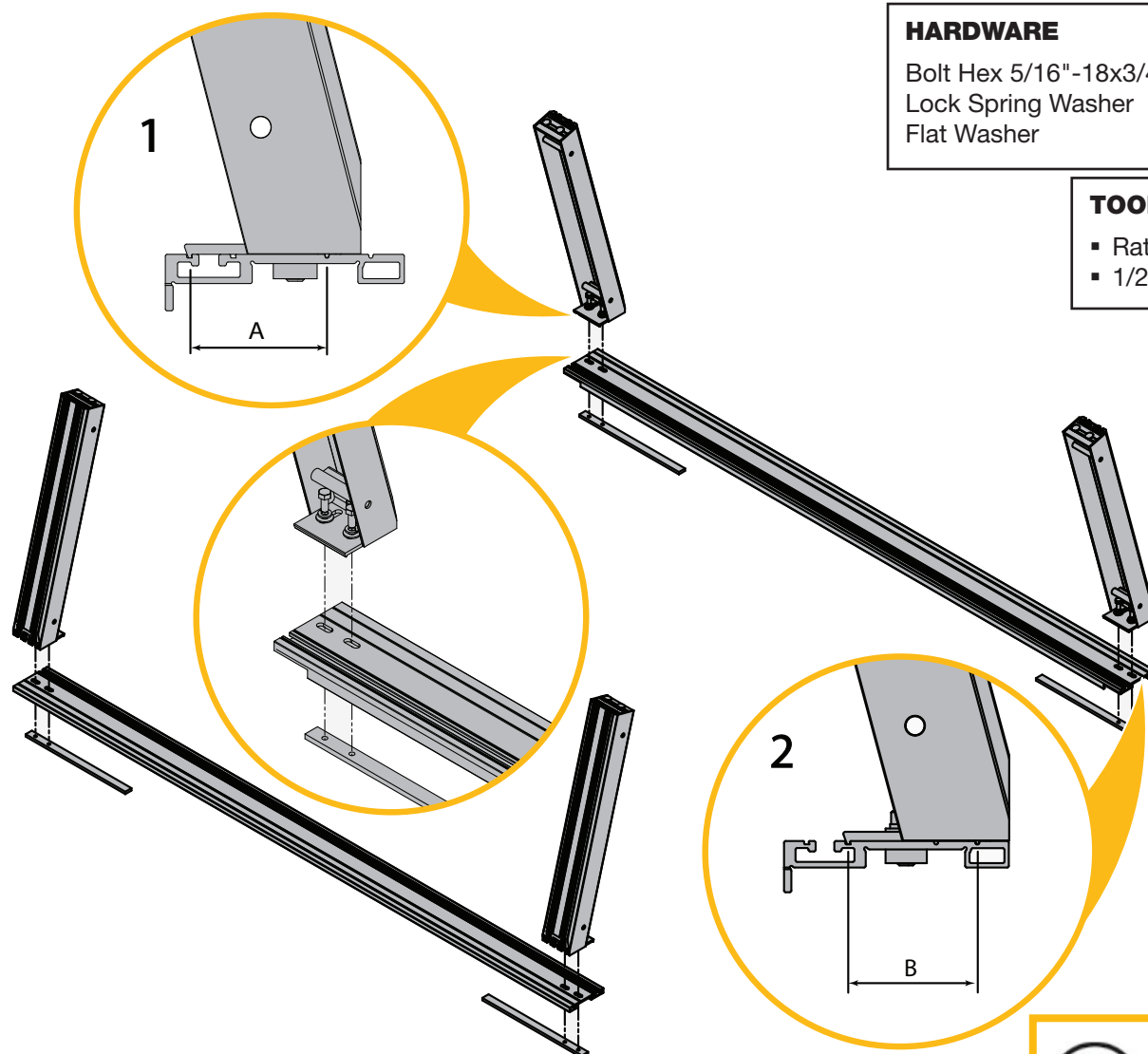

HARDWARE	
Bolt Hex 5/16"-18x3/4"	Qty: 8
Lock Spring Washer	Qty: 8
Flat Washer	Qty: 8

TOOLS	
▪ Ratchet	
▪ 1/2" Socket	

 Torque to 11 ft-lbs.

Model	1 Front	2 Rear
Chevrolet Silerado/GMC Sierra	A	B
Ford F150/Lightning	B	B
GMC Sierra/RAM 1500	B	B

Assembly

If installing boxes, skip the install of the rear gusset and only hand tighten the bolts.

NOTE:

- Use anti-seize provided when fastening bolts.

STEP 2 Insert long hex bolts into the uprights with the head facing outwards and tighten.

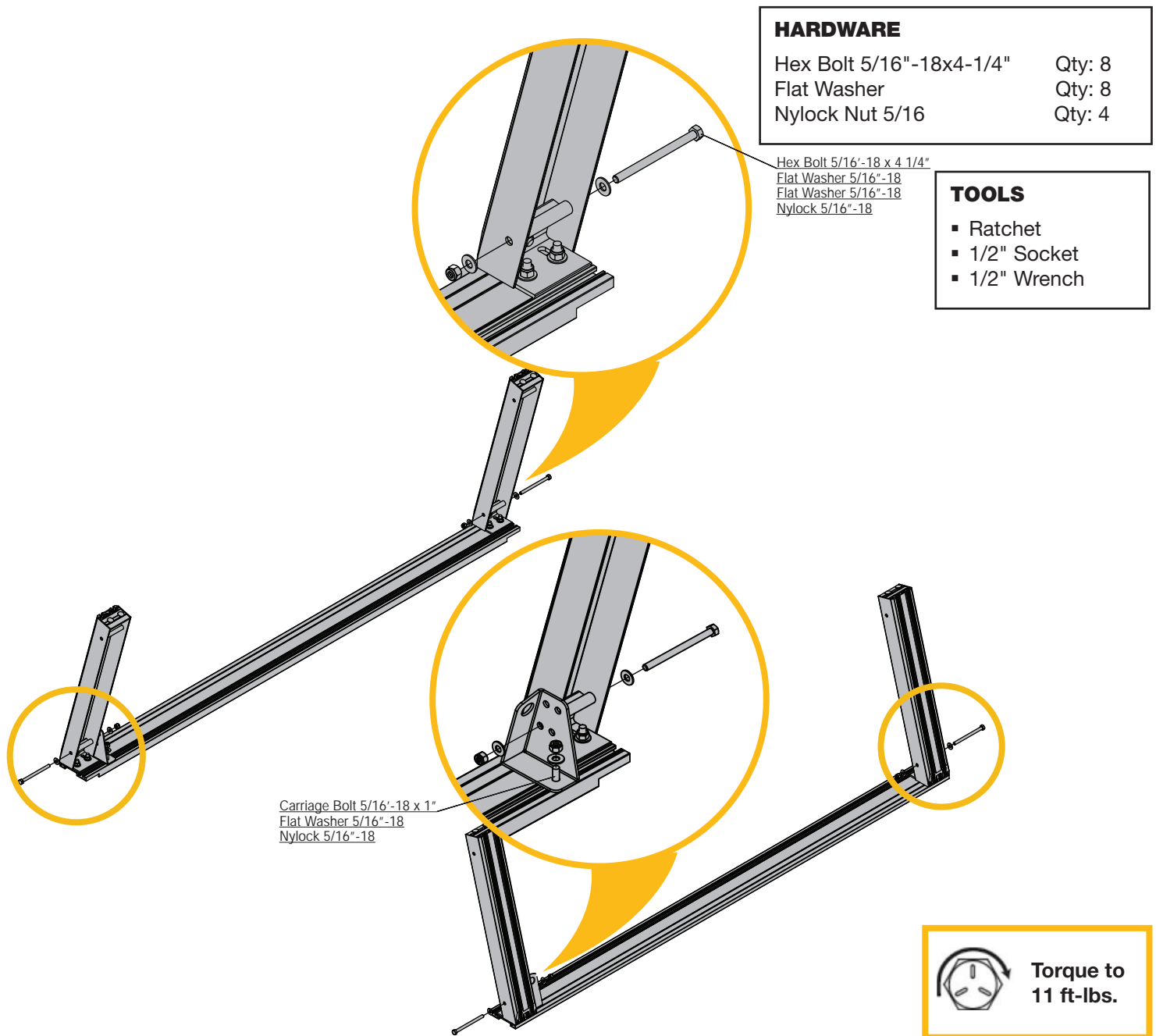

Assembly

NOTE:

- Use anti-seize provided when fastening bolts.

STEP 3 Slide in the transverse beams until flush with the end & tighten down the nuts pre-installed in the uprights.

TOOLS

- Ratchet
- 1/2" Socket

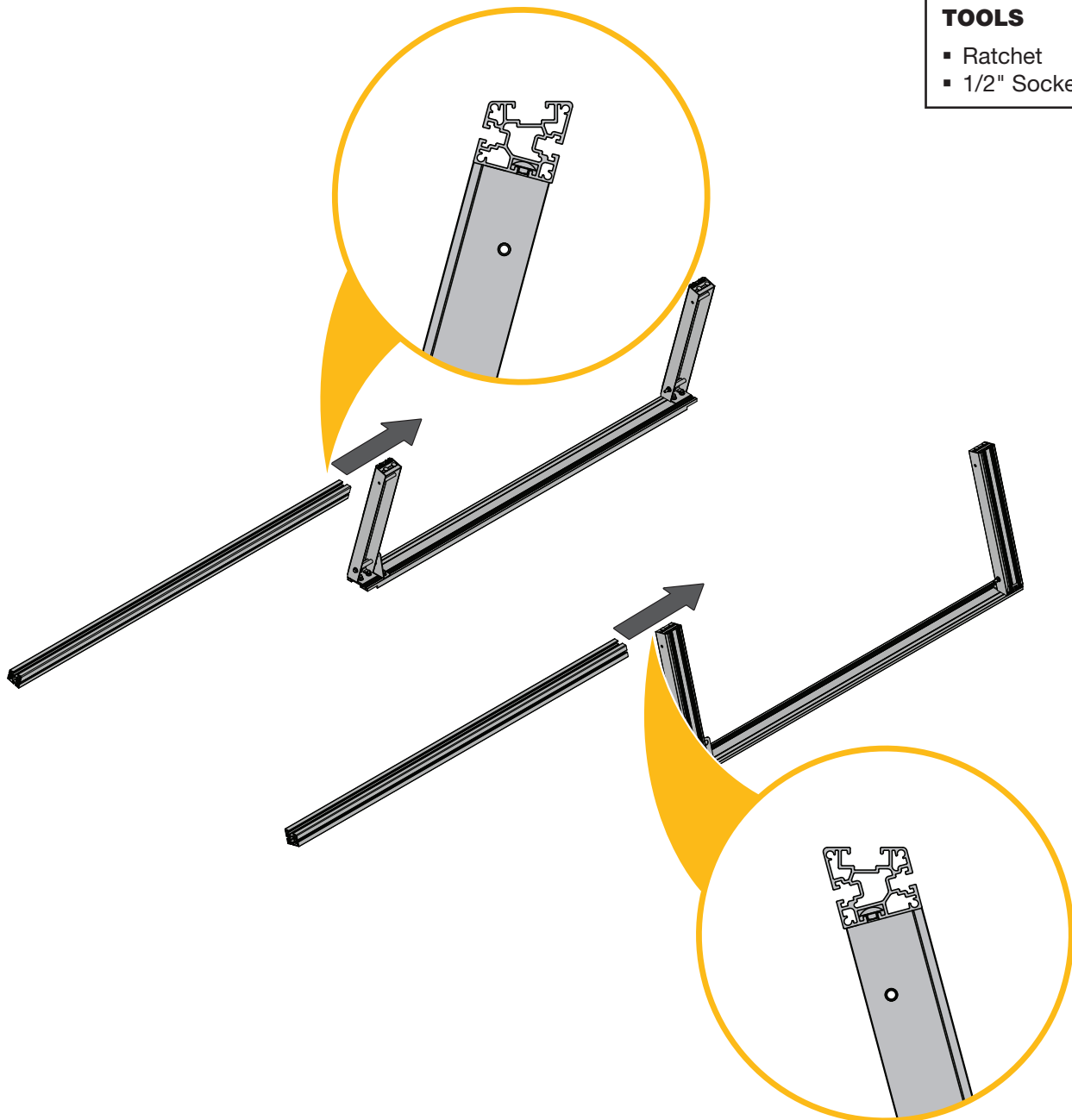

Torque to
11 ft-lbs.

Assembly

If installing boxes, skip this step.

NOTE:

- Use anti-seize provided when fastening bolts.

STEP 4 Slide 8 carriage bolts into each transverse beam and 2 hex bolts into each channel on the uprights. Install the gussets in the top corners of each side frame, picking up the carriage and hex bolts.

HARDWARE

Carriage Bolt 5/16"-18x 3/4"	Qty: 16
Hex Bolt 5/16"-18x 3/4"	Qty: 16
Flat Washer	Qty: 32
Lock Spring Washer	Qty: 32
Hex Nut 5/16"	Qty: 32

TOOLS

- Ratchet
- 1/2" Socket
- 1/2" Wrench

Bolt Hex 5/16"-18
Flat Washer 5/16"
Washer Lock Spring 5/16"
Nut Hex 5/16"

Nut Hex 5/16"-18
Washer Lock Spring 5/16"
Flat Washer 5/16"
Carriage Bolt 5/16"- 18.

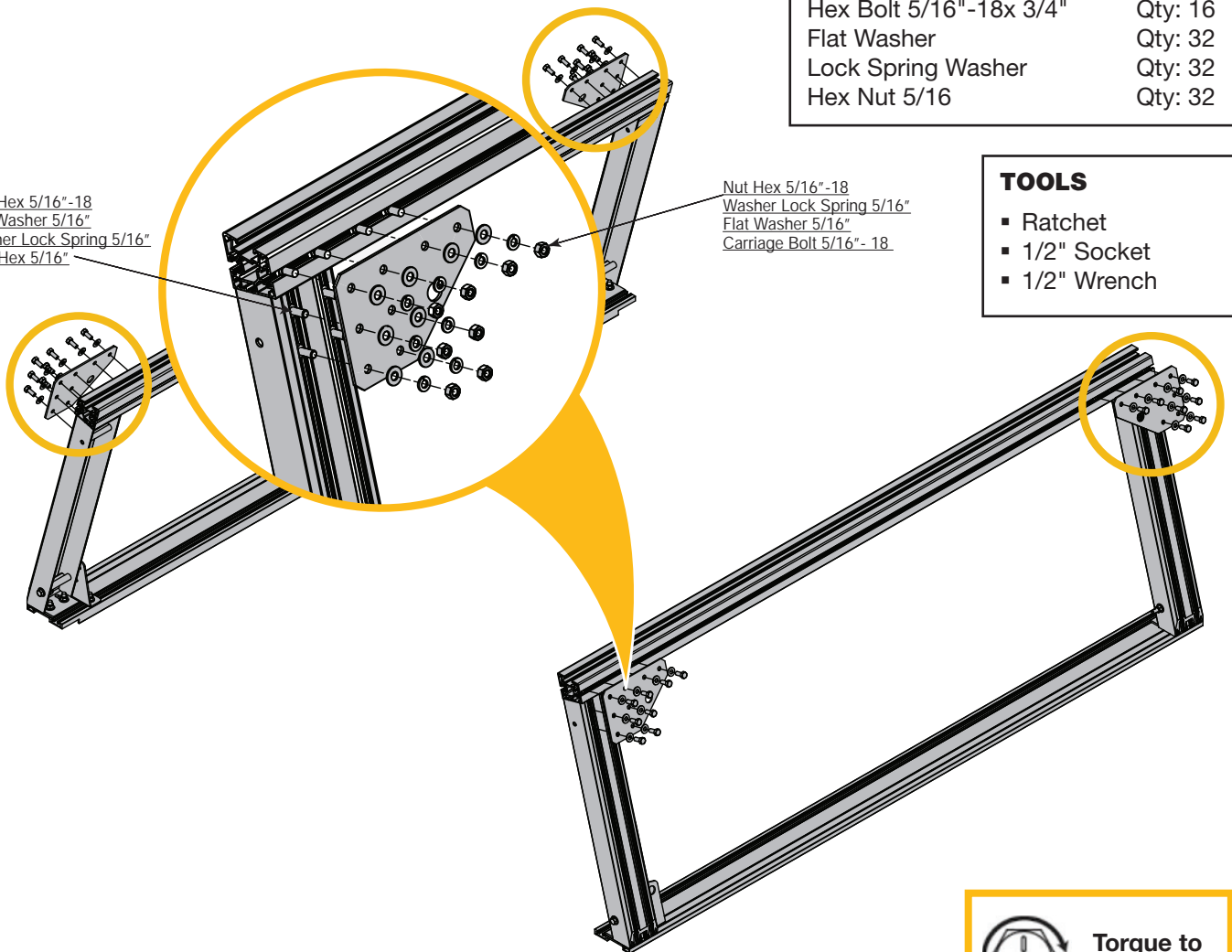

Torque to
11 ft-lbs.

Assembly

STEP 5 Slide in plates with carriage bolts.

HARDWARE

Carriage Bolt 5/16"-18x1-1/2 Qty: 8

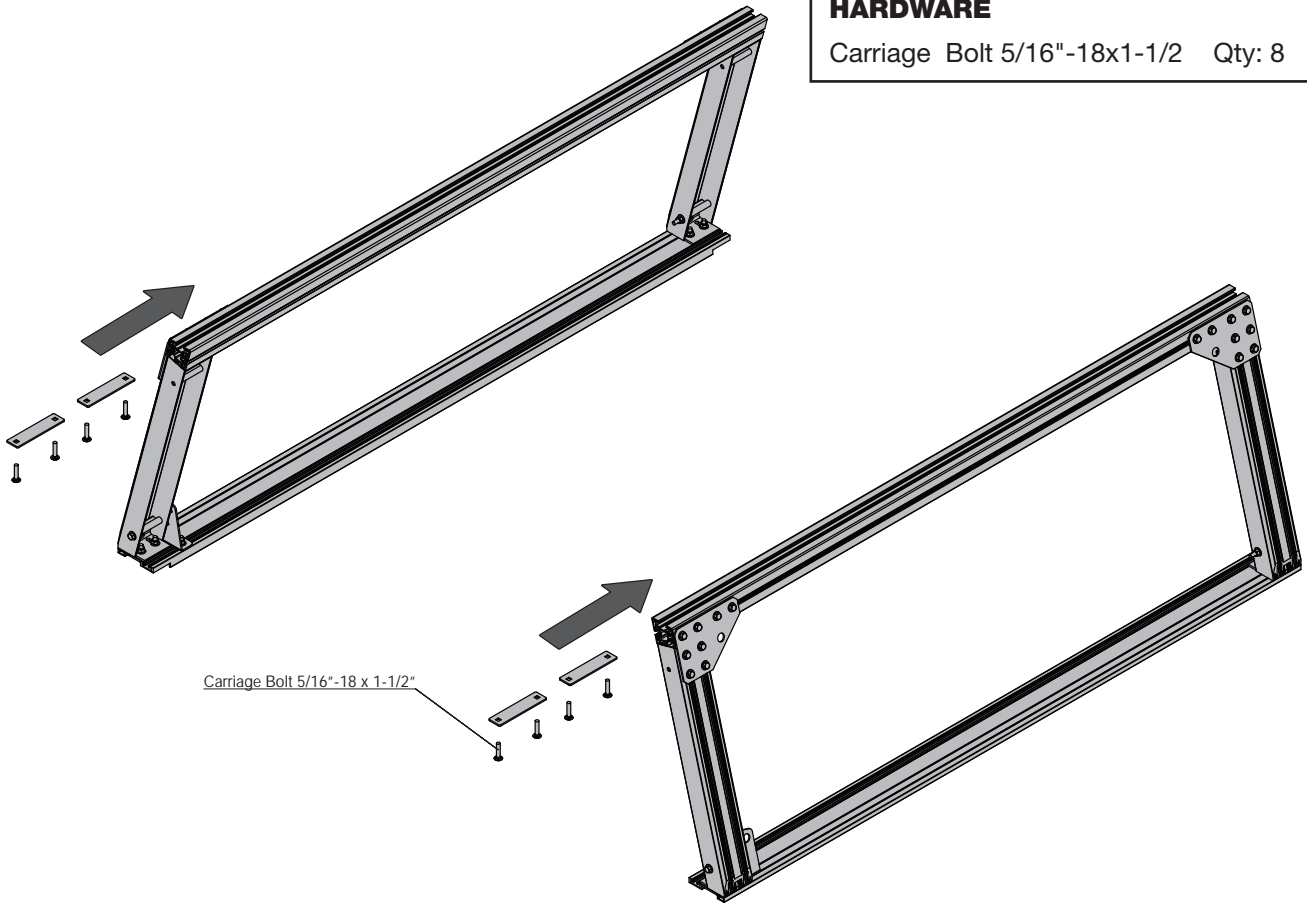

Assembly

NOTE:

- Use anti-seize provided when fastening bolts.

STEP 6 Install brackets on front and rear of transverse beams.

HARDWARE

Hex Bolt 5/16"-18x4-1/4	Qty: 4
Carriage Bolt 5/16"-18x1"	Qty: 8
Flat Washer	Qty: 16
Nylock Nut 5/16	Qty: 12

TOOLS

- Ratchet
- 1/2" Socket
- 1/2" Wrench

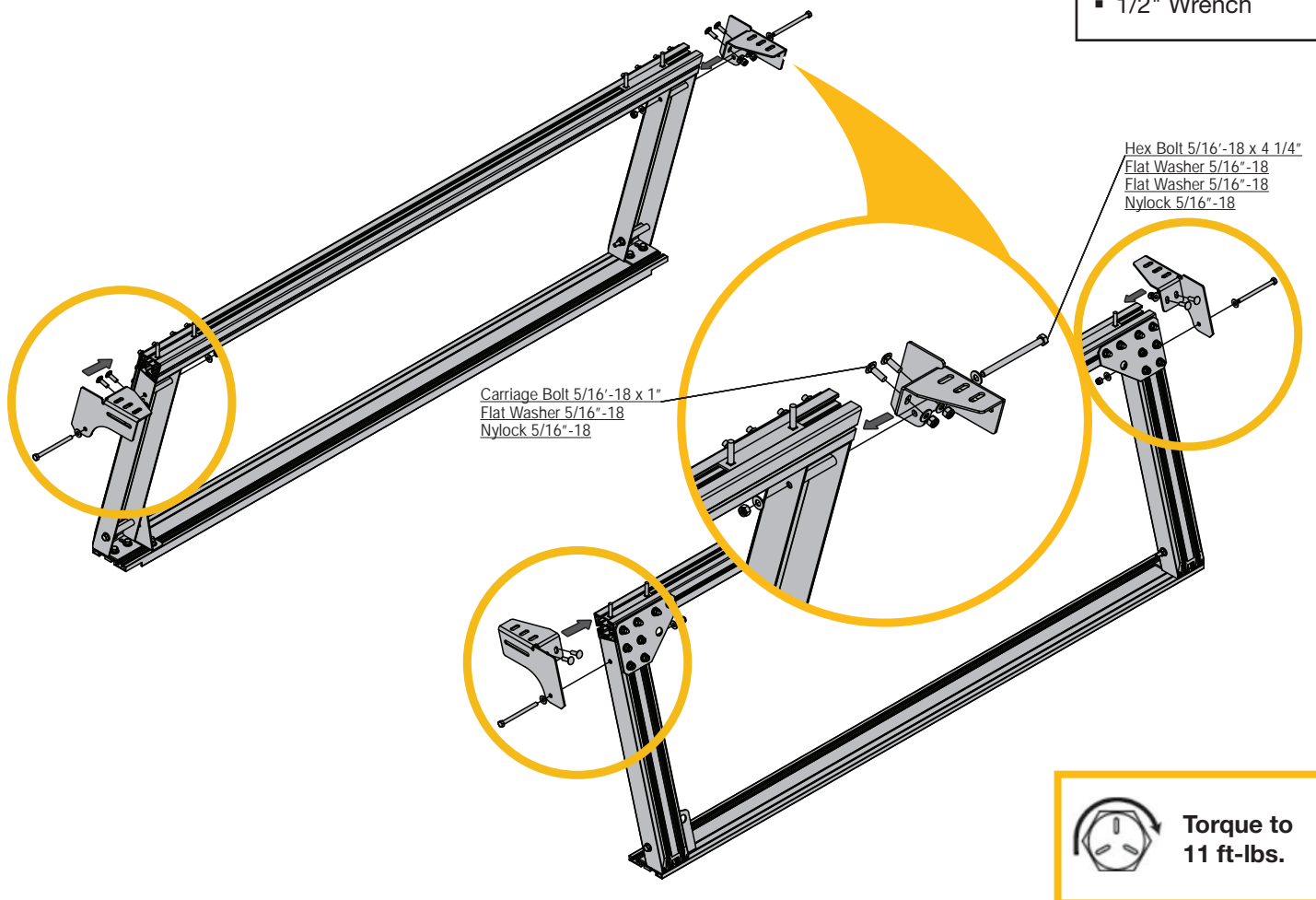

Assembly

NOTE:

- Use anti-seize provided when fastening bolts.

STEP 7 Set rack aside, assemble feet to crossbar A distance from the end.

HARDWARE

Hex Bolt 5/16" -18x2-3/4	Qty: 4
Flat Washer	Qty: 8
Nylock Nut 5/16	Qty: 4

TOOLS

- Ratchet
- 1/2" Socket
- 1/2" Wrench

Model	Distance
Chevrolet Silerado/GMC Sierra	7"
Ford F150/Lightning	6"
RAM 1500	7"

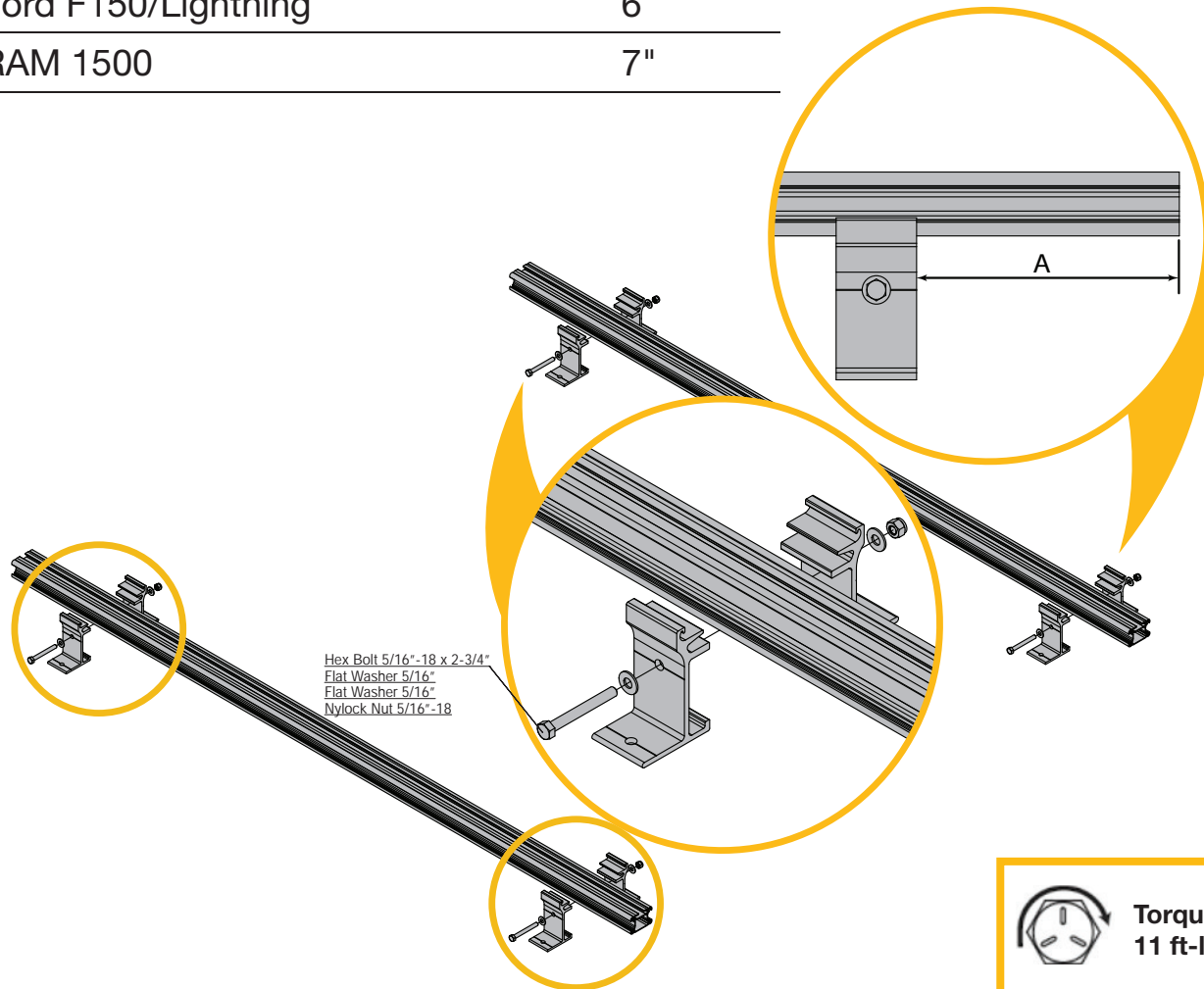

Assembly

Skip this step if installing additional ladder racks or accessories to the crossbars.

STEP 8 Add end caps to crossbars.

TOOLS

- Rubber Mallet

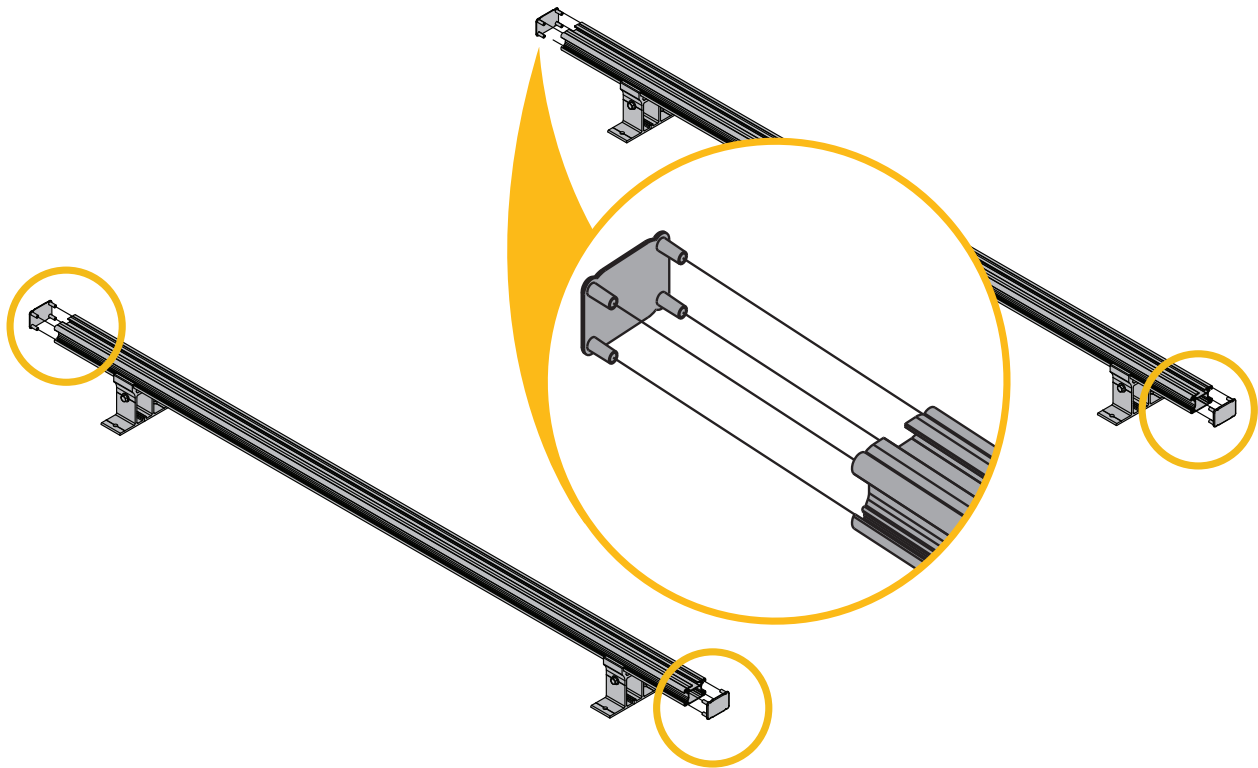

Installation

NOTE:

- For RRB-2080, use 3 clamps per side and space the 3rd clamp centered on the base rail.

STEP 9

Clamp each side to the truck bed ensuring an equal spacing, then tighten. Place the clamps on a smooth surface on the bed rail and bolt tip is flush and unobstructed under the bed rail. Ensure there is minimum distance of 3" and maximum of 7" from the upright edge.

TOOLS

- Ratchet
- 3/4" Socket
- 3/4" Wrench

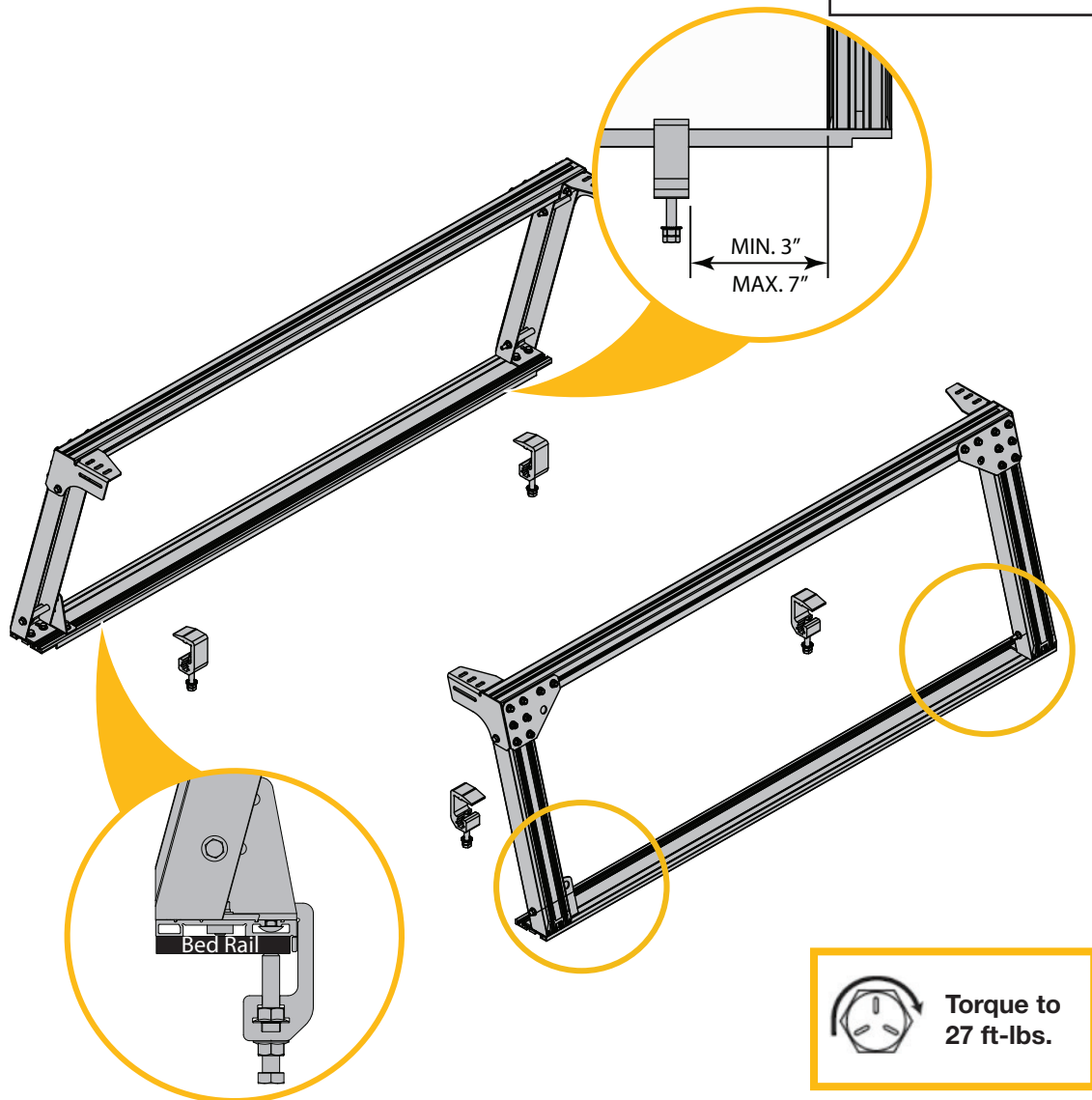

Installation

NOTE:

- Use anti-seize provided when fastening bolts.

STEP 10 Install front 20-0120 with logo and rear cross plates 20-012 no logo.

HARDWARE

Hex Bolt 5/16" -18x1"	Qty: 12
Flat Washer 5/16"	Qty: 24
Nylock Nut 5/16"	Qty: 12

TOOLS

- Ratchet
- 1/2" Socket

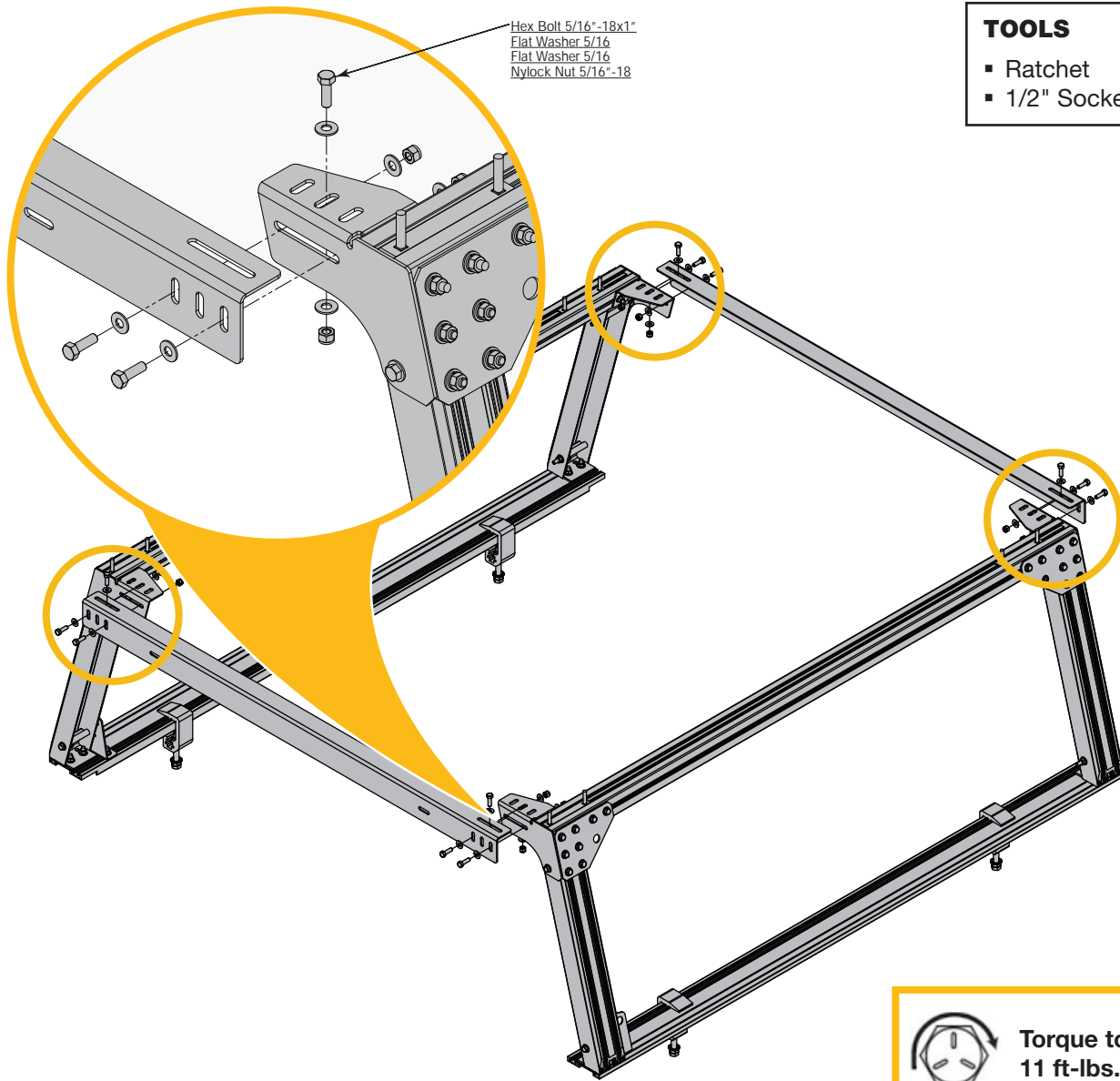

Installation

If installing OTC, skip the install of the front crossbar.

NOTE:

- Use anti-seize provided when fastening bolts.

STEP 11 Bolt the crossbars to the bolts slid into the transverse beams.

HARDWARE

Nut 5/16"-18	Qty: 8
Lock Washer 5/16"	Qty: 8
Flat Washer 5/16"	Qty: 8

TOOLS

- Ratchet
- 1/2" Socket

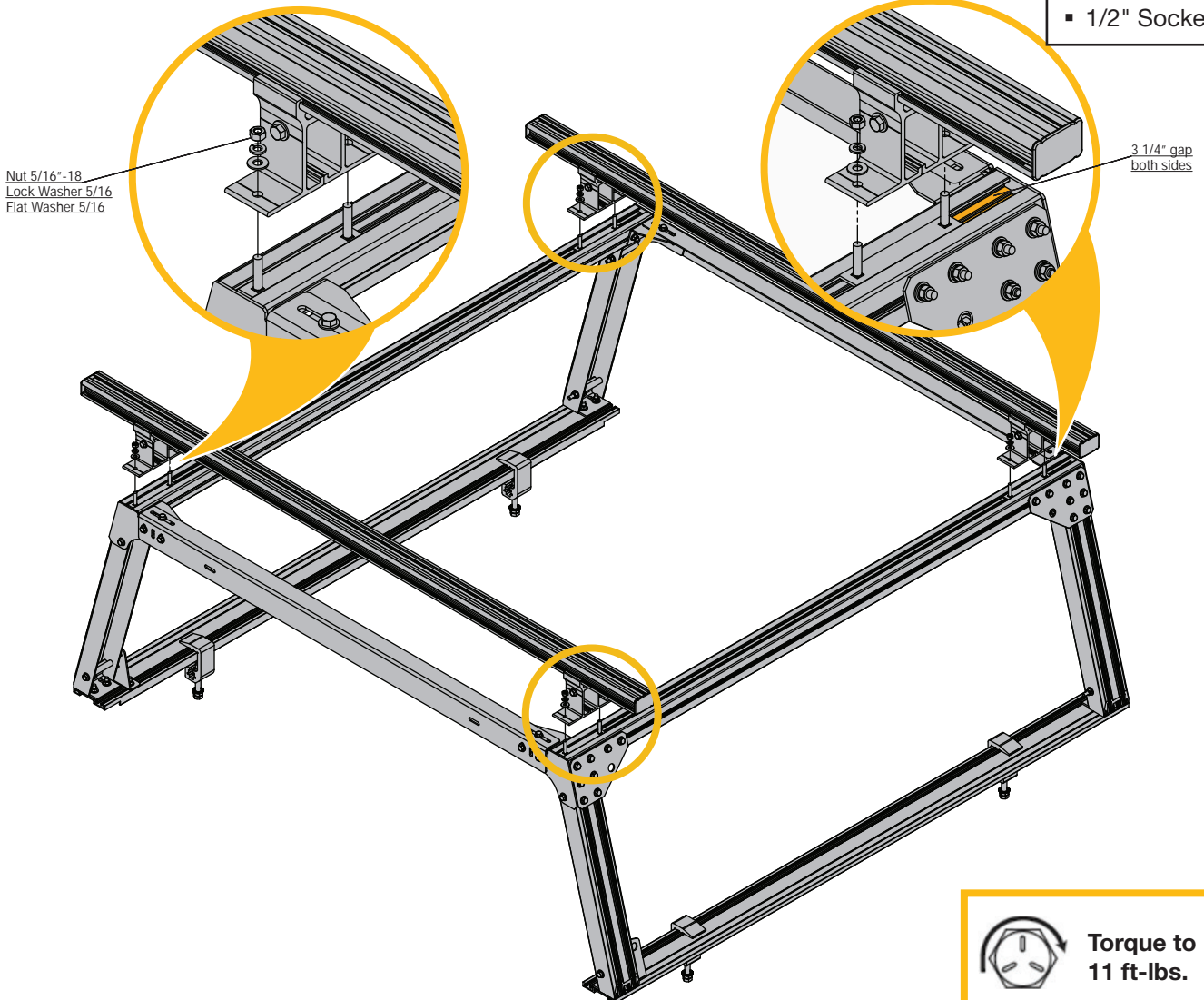

Installation

STEP 12 Select a warning label in the language best suited to your region and apply it to the rear upright. Use multiple stickers if required.

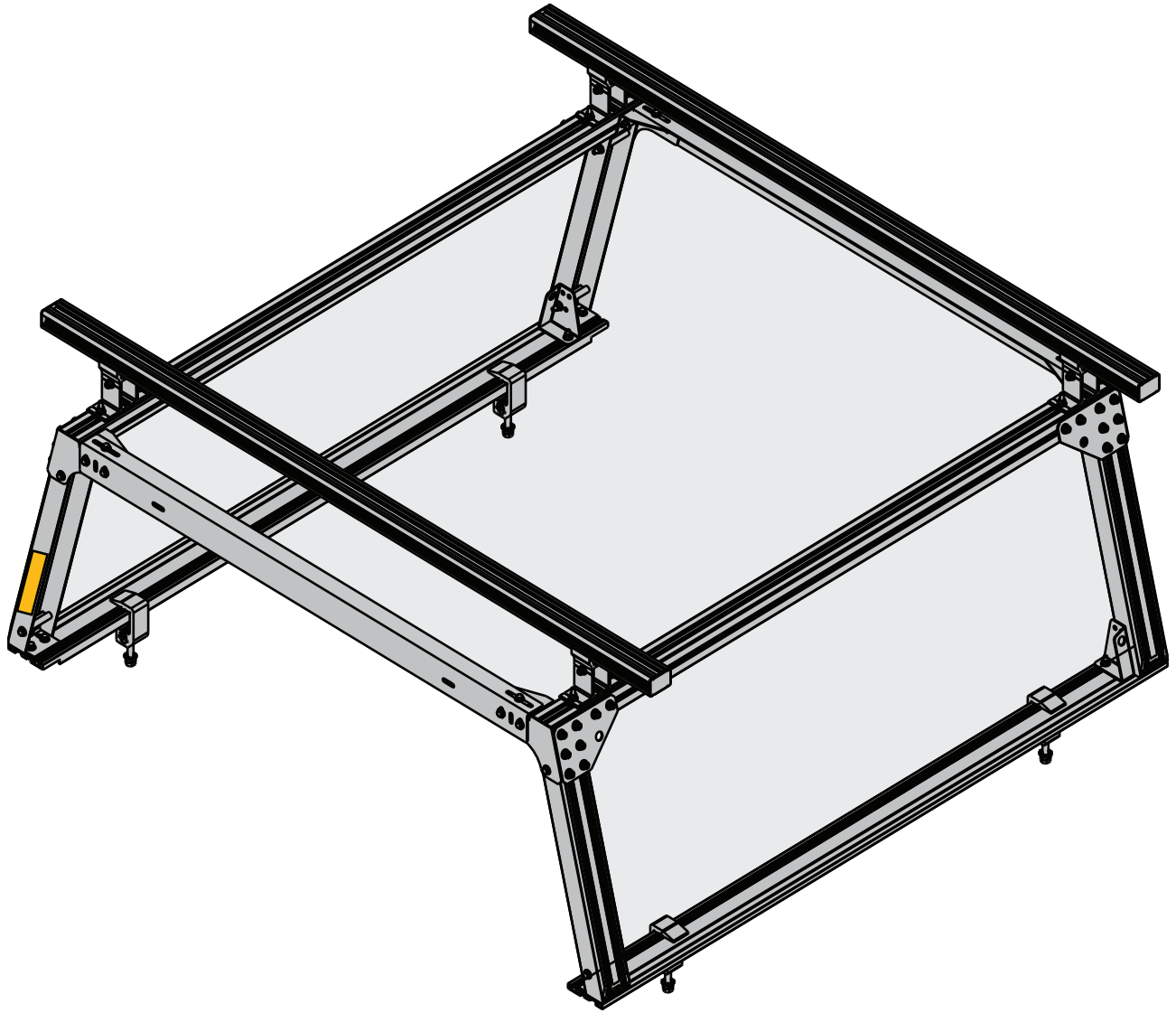

This page was intentionally left blank.

TRAZER

by **RANGER**[™]
DESIGN

You have successfully assembled and installed your RRB Series rack.

Thank you for doing business with us.

For technical support, contact us at 1-800-565-5321.

For any feedback or suggestions you may have, please contact cs@rangerdesign.com.

Copyright © 2024

All rights reserved. This manual or any portion thereof may not be reproduced or used in any manner whatsoever without the express written permission of Ranger Design, Inc.