

INSTALLATION GUIDE

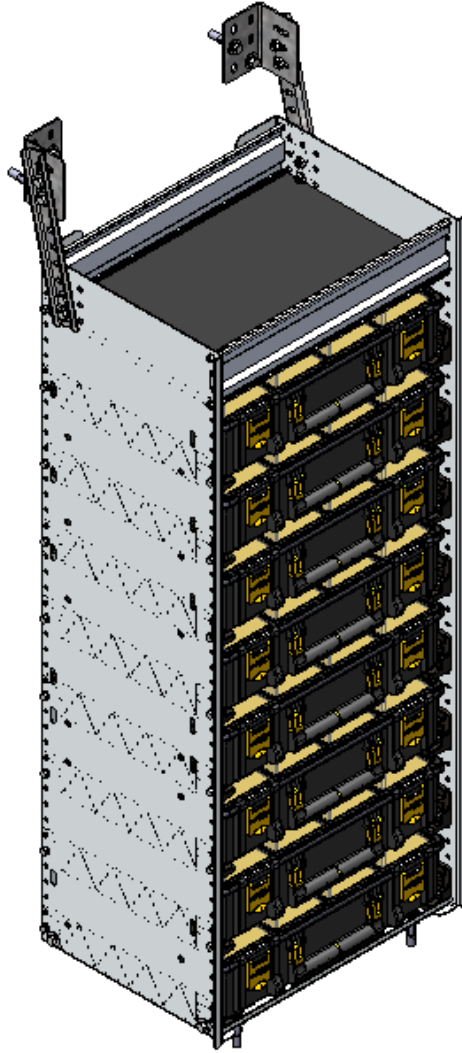

C4-PA18-8C Partskeeper Cabinet



Scan the QR for the latest Install-Guide.





BEFORE YOU BEGIN

READ, UNDERSTAND, AND FOLLOW ALL WARNINGS AND INSTRUCTIONS BEFORE USING THIS PRODUCT. FAILURE TO FOLLOW THESE DIRECTIONS MAY RESULT IN PROPERTY DAMAGE, SERIOUS BODILY INJURY, AND/OR DEATH. RANGER DESIGN IS NOT RESPONSIBLE FOR ANY PROPERTY DAMAGE, PERSONAL INJURY, OR DEATH THAT OCCURRED WHILE USING ANY RANGER DESIGN PRODUCTS.



WARNING

- Failure to use Ranger Design-provided fasteners, brackets, and proper installation guidelines could increase risk of serious personal injury and/or death.
- If drilling is required to complete this installation: improper drilling can cause property damage to vehicles and could lead to electric shock, fire, or even death.
- If drilling is required to complete this installation: Ensure that drilling is only performed on areas of the vehicle allowed by the vehicle's Original Equipment Manufacturer's Body Builders Layout Book (or equivalent document).
- Prior to installation, inspect the vehicle to ensure that installation will not interfere with, or cause obstruction of, any critical components such as electrical wiring, fuel tanks, fuel-cells, locks, latches, etc.
- The installer or manufacturer is responsible for ensuring anchorages are installed onto suitable wall and floor structures; wall and floor strength must meet applicable performance requirements.
- Do not install systems into any weak or unsound materials such as plastics, woods, thin-walled metals, etc. without proper reinforcement.
- Do not install this product where it could interfere with the deployment of airbags. Failure to comply could result in death or serious injury.
- Do not install this product where it could ingress on the Transit Occupant Protection Zone. Failure to comply could result in death or serious injury.
- Incorrect installation could cause water leaks, electric shock or fire.
- Any cargo vehicle with any cargo or equipment should use a certified partition. See Ranger Design website for some partition options. (<https://rangerdesign.com/>)
- Mountings rails are recommended for any attachment to the vehicle walls.
- All items in the cargo area should be properly secured and partition doors closed while the vehicle is in motion.
- Check your vehicle's tare weight and remaining load capacity with all the equipment installed. Never exceed the maximum Gross Vehicle Weight Rating (GVWR), Gross Axle Weight Ratings (GAWRs), or other maximum loads permitted by the vehicle's Original Equipment Manufacturer (OEM) and required by law.
- The heaviest items must be placed towards the bottom of the vehicle, while the lightest ones can be arranged upwards. Vehicle cargo loading weight proportion should follow the following guidelines:

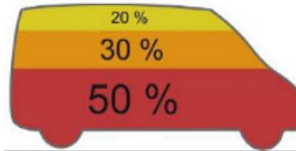

- The final alterer and/ or modifier should review the warning sheet with the customer before the vehicle is released to the customer or for general use. These instructions should remain with the vehicles a all times.
- Any modification or unintended use of this product voids any warranty and could create a hazardous condition.
- Ranger Design provides recommended assembly and installation instructions which should be followed to ensure correct operation. Failure to do so could result in invalidating the product's compliance, warranty and cause injury. Notwithstanding, the final stage vehicle alterer and/or modifier is responsible for the integration, installation, and compliance of the product in its final location to all applicable regulations and standards. Failure to maintain compliance of the vehicle to applicable regulations and standards could be punishable by law. Alterers and/or modifiers should consult with all local authorities prior to commissioning.



CAUTION

- Drilling is required to complete this installation. Before drilling, ensure that you will not hit any critical parts of the vehicle like the gas tank, wiring harness, or hose. Consult the vehicle OEM documentation as necessary. When drilling, use a drill collar to reduce the risk of damage to the vehicle.
- Any materials, padding, or glazing installed in the vehicle must comply with FMVSS/CMVSS 201/205/302, as applicable.
- In the event of a motor vehicle accident or collision where a Ranger system has been installed, especially ones where the vehicle structure is damaged and/or the air bags deploy and/or the vehicle has been towed, the system must be inspected to ensure continued soundness and safety before returning the vehicle to service. Damaged components should be replaced as necessary.
- All system components should be regularly inspected, cleaned, and maintained pursuant to Ranger guidelines.

QUICK START GUIDE

Phase 1 - Assembly

<input type="checkbox"/> 1.1 Setup.....	4
<input type="checkbox"/> 1.2 Shelf Assembly.....	7

Phase 2 - Installation

<input type="checkbox"/> 2.1 Attach Wall Brackets To The End Panels.....	9
<input type="checkbox"/> 2.2 Mark Holes For Plus Nuts.....	10
<input type="checkbox"/> 2.3 Attach Plus Nut.....	11
<input type="checkbox"/> 2.4 Attach Partskeeper Cabinet To the Floor.....	13
<input type="checkbox"/> 2.5 Attach Wall Brackets.....	15

REQUIRED ITEMS

- Cordless Impact
- Cordless Drill
- Tape Measure
- Marker
- 1/2" Socket
- 1/2" Drill Bit w/ Drill Collar (Set at 1/2")
- 3/8" Driver Bit
- Knife
- Plusnut Tool / Plusnut Gun (5/16")

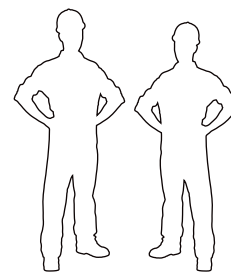

2
PERSONS

PHASE 1 – ASSEMBLY

1.1 SETUP

1.1.1 Unpack components; compare with the bill of materials.

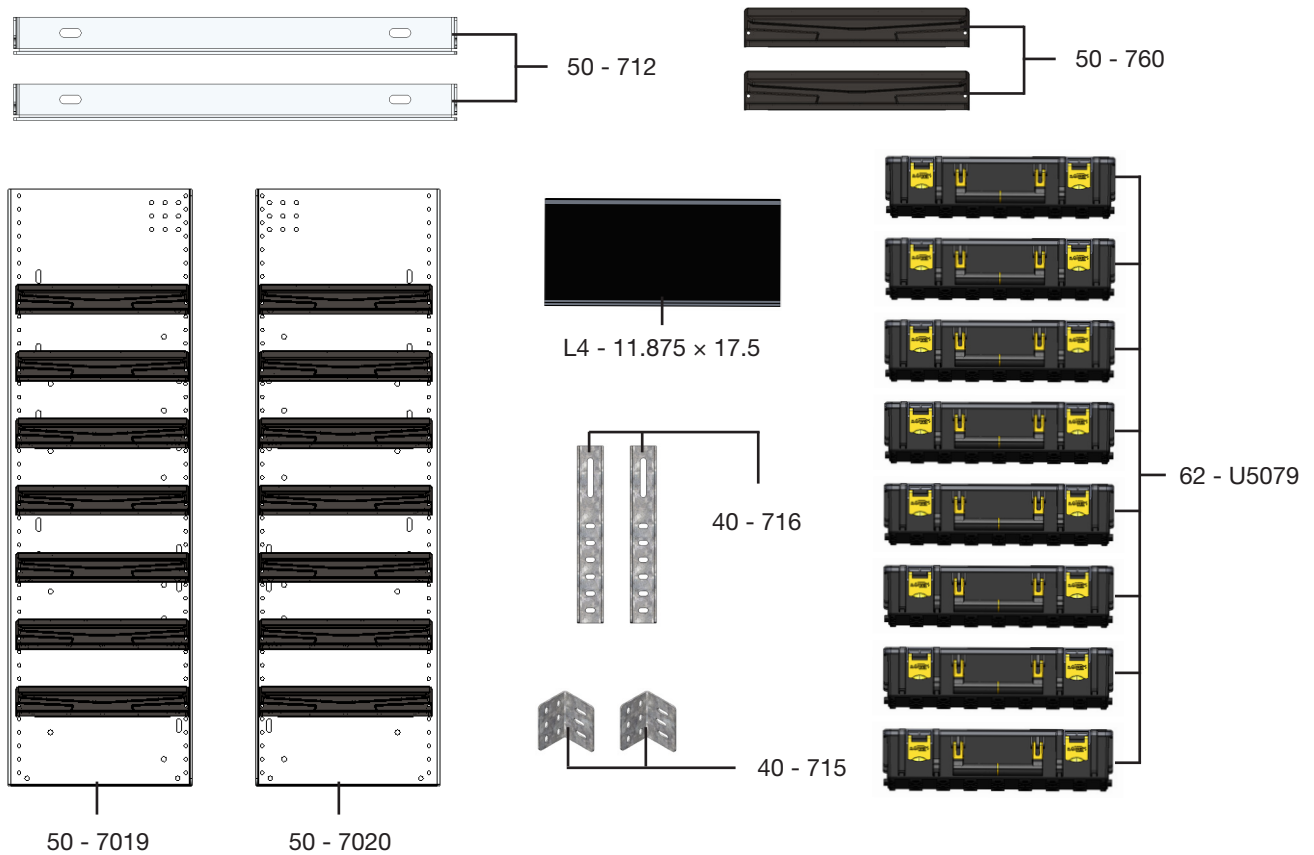

1.1.2 Verify all parts are present.

BILL OF MATERIALS

Item No.	Description	Qty.
40 - 715	Bracket Head	2
40 - 716	Bracket Arm	2
50 - 712	Floor Bracket	2
50 - 760	Partskeeper Rail	2
50 - 7019	End Panel (Left)	1
50 - 7020	End Panel (Right)	1
62-U5079	Plastic Partskeeper Case	8
L4 - 11.875 × 17.5	Shelf Tray, Composite, Usable 12" × 17.5"	1
94 - 5022	Assembly Fastener Kit	1
96 - 5022	Install Fastener Kit	1

1.1.3 Fastener kits.

94 - 5022 Fastener Kit

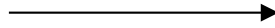

Fastener Assembly

12x



90-204

Hex Bolt
5/16"-18 x 3/4"
GR-5 ZINC

4x



90-012

Screw HWH
1/4"-10 x 3/4"
ZINC

8x



92-102

Screw HWH
#14 x 1"
ZINC

12x



94-116

Serrated Nut
5/16"-18
ZINC

12x



98-116

Flat Washer
5/16"
ZINC

12x

	#90-204 Hex Bolt	5/16" x 3/4"
	#98-116 Flat Washer	5/16"
	#94-116 Serrated Nut	5/16"

4x

	#90-012 Screw	1/4"-10 x 3/4"
--	---------------	----------------

8x

	#92-102 Screw	#14 x 1"
--	---------------	----------

96 - 5022 Fastener Kit

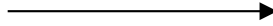

Fastener Assembly

4x  # 90-011 Hex Bolt
5/16"-18 x 1-3/4"
GR-5 ZINC

4x  # 90-212 Hex Bolt
5/16"-18 x 1-1/4"
GR-5 ZINC





8x  # 94-132 Plusnut

8x  # 98-116 Flat Washer
5/16", O.D. 7/8"
ZINC





8x  # 98-122 Lock Washer
5/16"
ZINC

4x  # 98-157 Spacer
0.375" ID, x 1.0" OD x 0.25" LONG
NYLON

4x

	#90-212 Hex Bolt 5/16" x 1-1/4"
	#98-122 Lock Washer
	#98-116 Flat Washer
	#94-132 5/16" Plusnut

4x

	#90-011 Hex Bolt 5/16" x 1-3/4"
	#98-122 Lock Washer
	#98-116 Flat Washer
	#98-157 Spacers (QTY = GAP BETWEEN FLOOR AND END PANEL)
	#94-132 5/16" Plusnut

PHASE 1 – ASSEMBLY

1.2 SHELF ASSEMBLY

1.2.1 Attach the bracket head to the bracket arm.

NOTE: Hand-tighten the bolts for adjustment.

x2

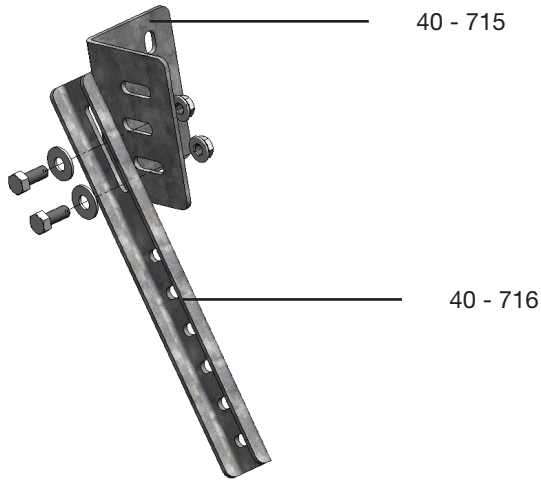

TOOLS

- Cordless Impact
- 1/2" Socket

HARDWARE USED

4x HAND-TIGHTEN THE BOLTS



#90-204 Hex Bolt 5/16" x 3/4"



#98-116 Flat Washer



#94-116 Serrated Nut

1.2.2 Attach both panels to the shelf trays.

IMPORTANT: Assemble the partskeeper on a protected clean surface to avoid scratching.

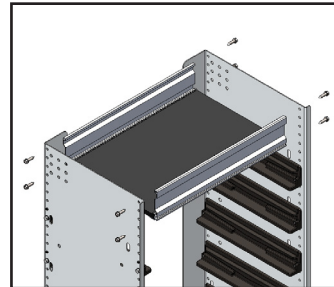
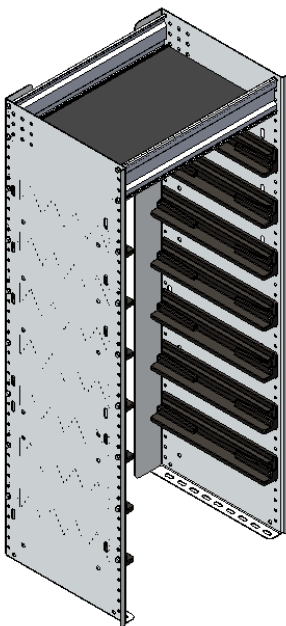

TOOLS

- Cordless Impact
- 3/8" Driver Bit

HARDWARE USED

8x 94-5022



#92-102 Screw #14 x 1"

1.2.3 Attach 2 bottom brackets to the end panels.

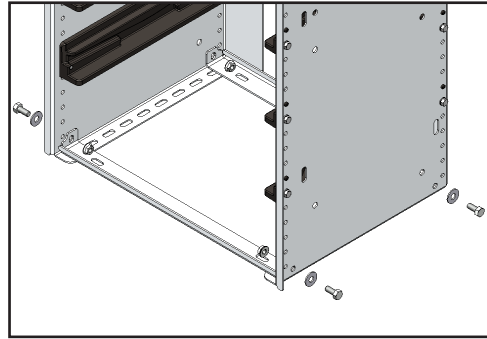
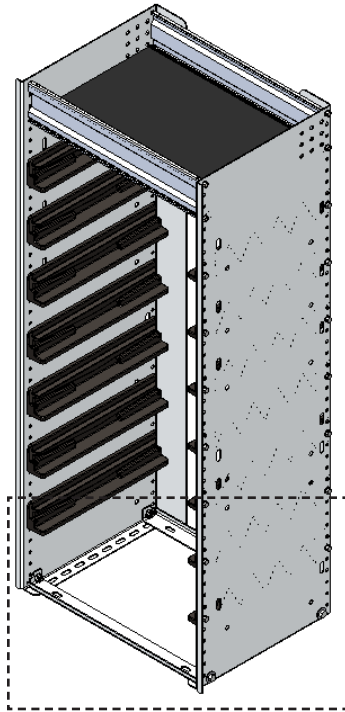



TOOLS

- Cordless Impact
- 1/2" Socket

HARDWARE USED

4x 94-5022

-  #90-204 Hex Bolt 5/16" x 3/4"
-  #98-116 Flat Washer
-  #94-116 Serrated Nut

1.2.4 Attach 1 partskeeper rail on the bottom of each end panel.

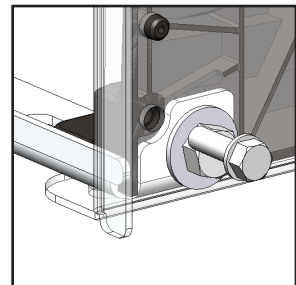
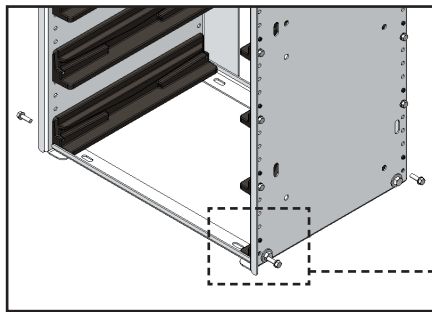
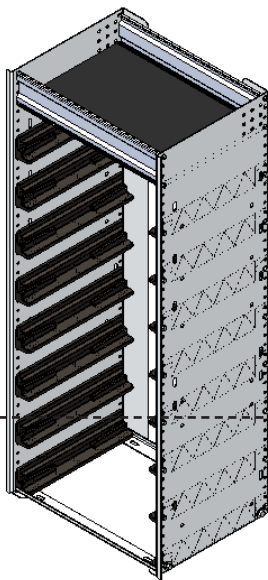

TOOLS

- Ratchet
- 3/8" Driver Bit

HARDWARE USED

4x 94-5022

-  90-012 Screw 1/4"-10 x 3/4"

PHASE 2 – INSTALLATION

2.1 ATTACH WALL BRACKETS TO THE END PANELS

IMPORTANT: For all **Box Trucks**, make sure that the shelving is securely fastened to the structure of the truck.

- 2.1.1**
- Lift the assembled partskeeper cabinet to the vehicle, then put it in place.
 - Attach the wall brackets to the panels aligning the brackets to the horizontal rim of the vehicle.

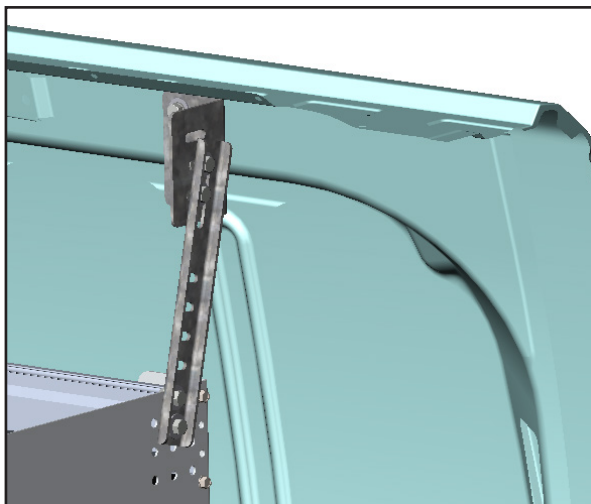
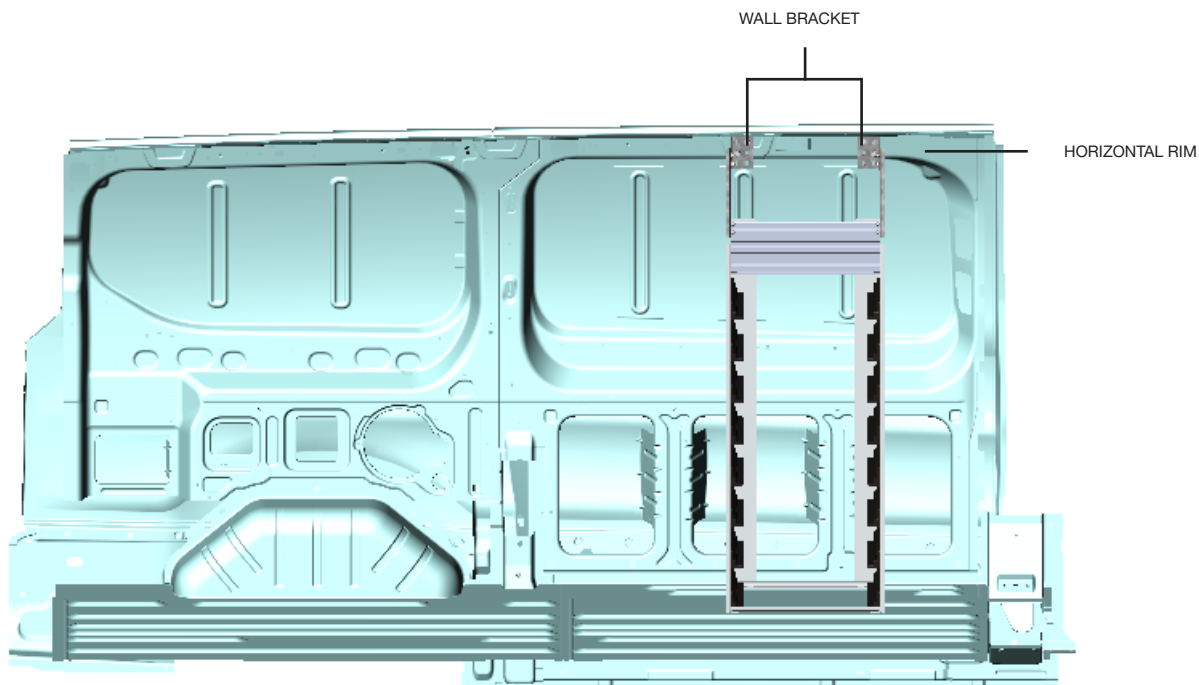



Attach the wall brackets to the panels aligning the brackets to the horizontal rim of the vehicle.

TOOLS

- ☐ Cordless Impact
- ☐ 1/2" Socket

HARDWARE USED

4x 94-5022

- | | |
|---|-------------------------------|
|  | #90-204 Hex Bolt 5/16" x 3/4" |
|  | #98-116 Flat Washer |
|  | #94-116 Serrated Nut |

PHASE 2 – INSTALLATION

2.2 MARK HOLES FOR PLUS NUTS

2.2.1 After attaching the brackets mark the holes on the brackets and bottom shelf to the vehicle.

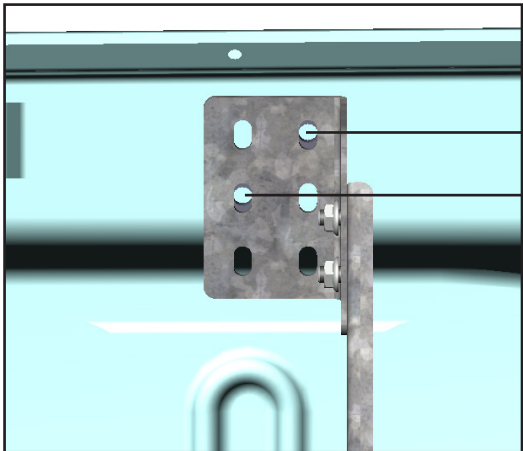
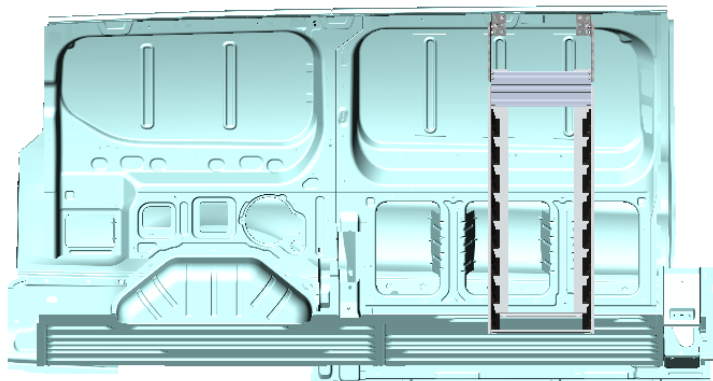

Mark 2 holes of the short and long brackets on the vehicle horizontal rim.

NOTE: If you are using Ranger wall kits, please go to **PAGE 14**.

TOOLS
 Marker

MARK

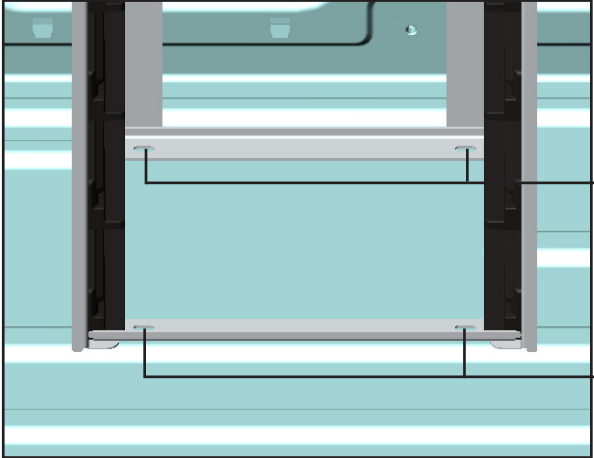

Mark the 2 holes of each floor bracket on the vehicle floor.

NOTE: If you are using Ranger floor, please go to **PAGE 12**.

TOOLS
 Marker

MARK

PHASE 2 – INSTALLATION

2.3 ATTACH PLUS NUTS

- 2.3.1**
- Lift the assembled partskeeper cabinet on the side.
 - Drill all the marks using 1/2" drill bit w/ drill collar, then attach plus nuts to the holes.

NOTE: Use 1/2" drill bit with drill collar to stop drill at 1/2" depth.

WARNING: Before drilling, ensure that you will not hit any critical parts of the vehicle like the **Gas tank**, **Wiring Harness** and **Hose**.

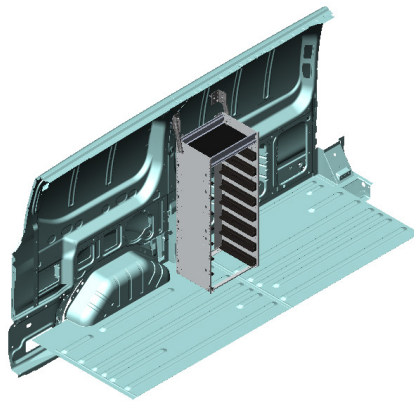

PLUSNUT

Drill all the marks then, attach plus nuts to the holes.

TOOLS

- Cordless Drill
- 1/2" Drill Bit w/ Drill Collar (Set at 1/2")
- Plus Nut Tool (5/16")

HARDWARE USED

8x 96-5013

	#94-132 Plus Nut
---	------------------

DRILL COLLAR
(SET AT 1/2")

2.3.2 How to attach plus nut.

• USING PLUSNUT GUN

STEP: Put the plusnut on the plusnut gun, then attach the plus nut in the hole by turning the gun forward until the plus nut locks, then remove the gun by turning in reverse.

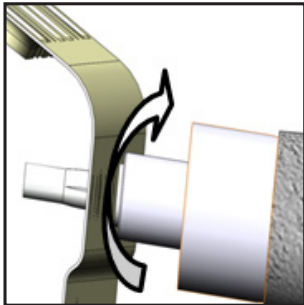

FORWARD

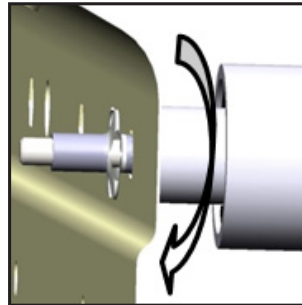

REVERSE

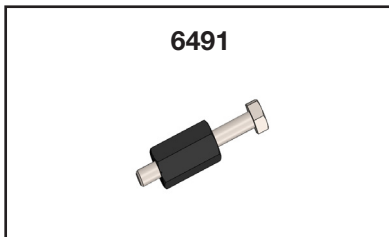

• USING THE 6491 PLUSNUT TOOL

NOTE: The hardware used for the 6491 plusnut tool is not included in the fastener bag. The 6491 plusnut tool can be ordered separately upon demand at no charge.



6491

HARDWARE USED

-  Flat washer 5/16"
-  Flat washer 5/16" BS x 7/8" OD

TOOLS

- Cordless Impact
- 1/2" Socket
- 9/16" Wrench

STEP 1:

Assemble the 6491 plusnut tool with the hardware needed, plus nut and the 9/16" wrench as shown.



STEP 2:

Attach the plus nut in the hole by turning the bolt forward using an impact with a 1/2" socket until the plusnut locks, then remove the bolt by turning the impact in reverse.

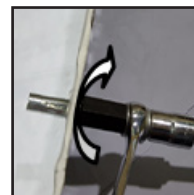

FORWARD



REVERSE

PHASE 2 – INSTALLATION

2.4 ATTACH PARTSKEEPER CABINET UNIT TO THE FLOOR

WITHOUT RANGER FLOOR

2.4.1 Put the assembled partskeeper cabinet back in place aligning the holes to the plusnuts, then install the bottom shelf to the plus nuts.

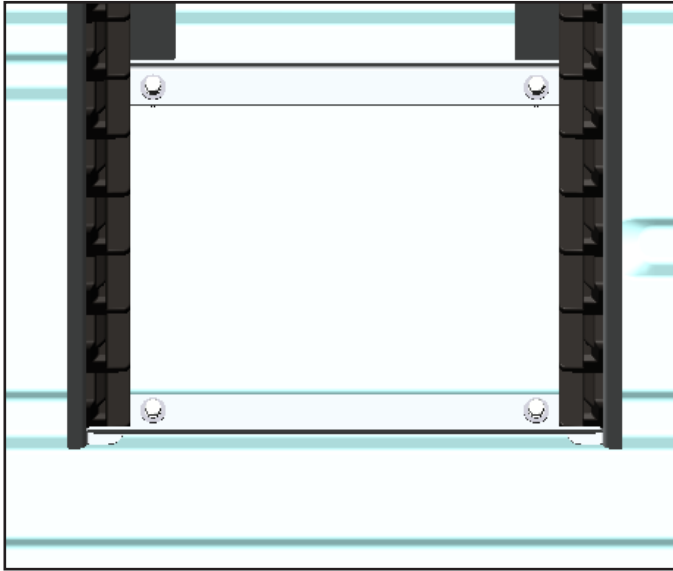
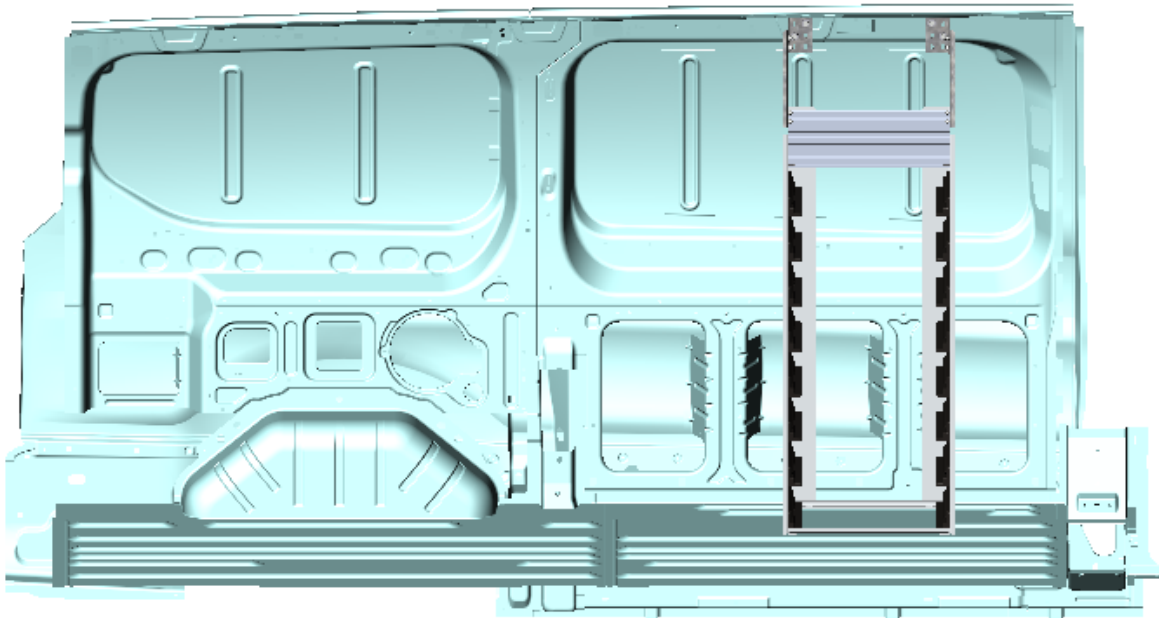





TOOLS

- Cordless Impact
- 1/2" Socket

HARDWARE USED

4x 96-5013

	#90-011 Hex Bolt 5/16" x 1-3/4"
	#98-122 Lock Washer
	#98-116 Flat Washer
	#98-157 Spacers (QTY = GAP BETWEEN FLOOR AND END PANEL)
	#94-132 5/16" Plusnut

WITH RANGER FLOOR

- 2.4.2
- Lift the partskeeper cabinet inside the van, then put it in place.
 - Mark the 2 holes of each floor bracket, then place the partskeeper cabinet on the side.
 - Drill the marks on the floor using 1" hole saw, then drill holes into the van floor for plus nut.
 - Attach plus nut in the van floor, then lift the partskeeper cabinet back in place, and attach the floor bracket to the plus nut.

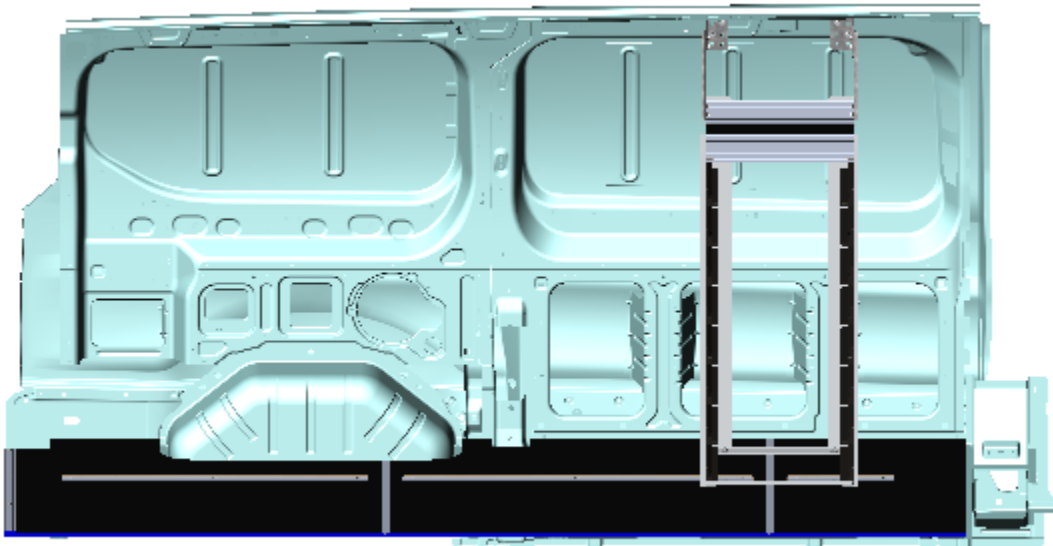

TOOLS

- Cordless Impact
- Cordless Drill
- 1/2" Drill Bit w/ Drill Collar (Set at 1/2")
- Plus Nut Tool (5/16")
- 1/2" Socket
- 1" Hole Saw

HARDWARE USED

4x 96-5013



#90-011 Hex Bolt 5/16" x 1-3/4"

#98-122 Lock Washer

#98-116 Flat Washer

#98-157 Spacers

#94-132 5/16" Plusnut

PHASE 2 – INSTALLATION

2.5 ATTACH WALL BRACKETS

WITHOUT RANGER WALL KITS

2.5.1 Align the wall brackets to the plus nuts, then install the wall brackets to the wall.

NOTE: Tighten the bolts that attach the bracket to the wall or wall rails 1st before tightening the bolts from the brackets to the end panels.

IMPORTANT: After installation is completed, ensure all bolts are tightened.

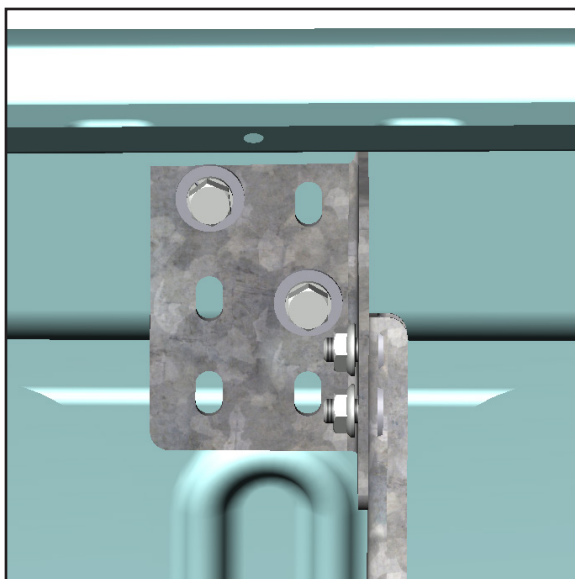
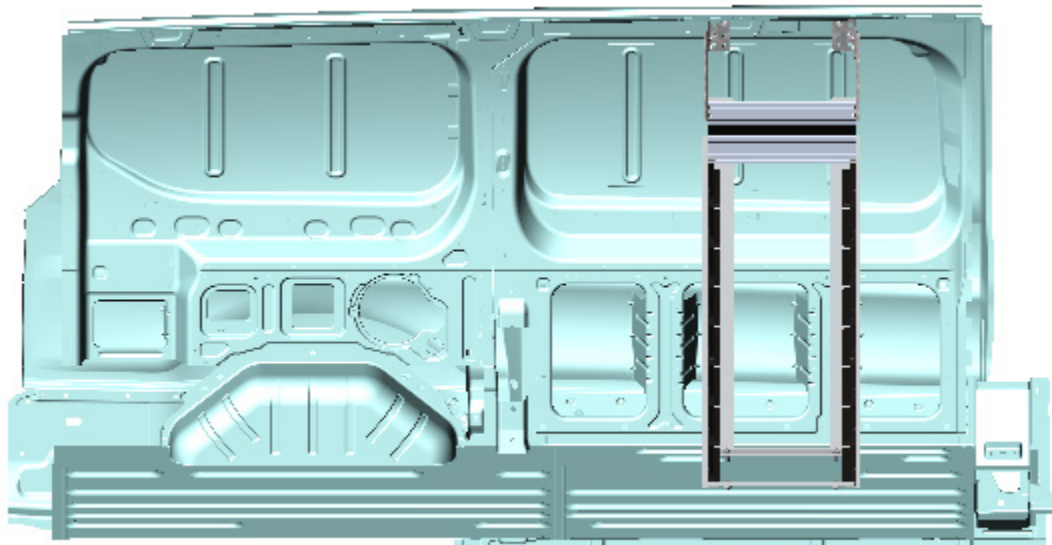

TOOLS

- Cordless Impact
- 1/2" Socket

HARDWARE USED

4x 96-5013



#90-212 Hex Bolt 5/16" x 1-1/4"

#98-122 Lock Washer

#98-116 Flat Washer

#94-132 5/16" Plusnut

WITH RANGER WALL KITS

2.5.2 Aligned the wall brackets to the wall mounting track kits, then install the wall brackets to the wall mounting track kits using channel nuts.

NOTE: Tighten the bolts that attach the bracket to the wall or wall rails 1st before tightening the bolts from the brackets to the end panels.

IMPORTANT: After installation is completed, ensure all bolts are tightened.

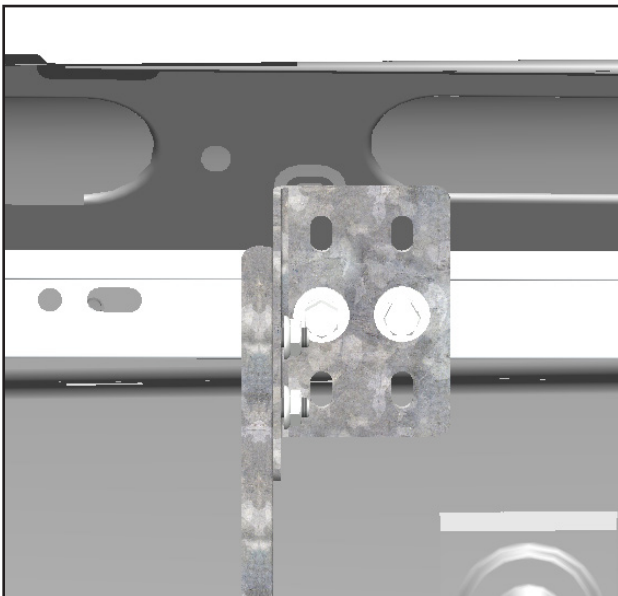
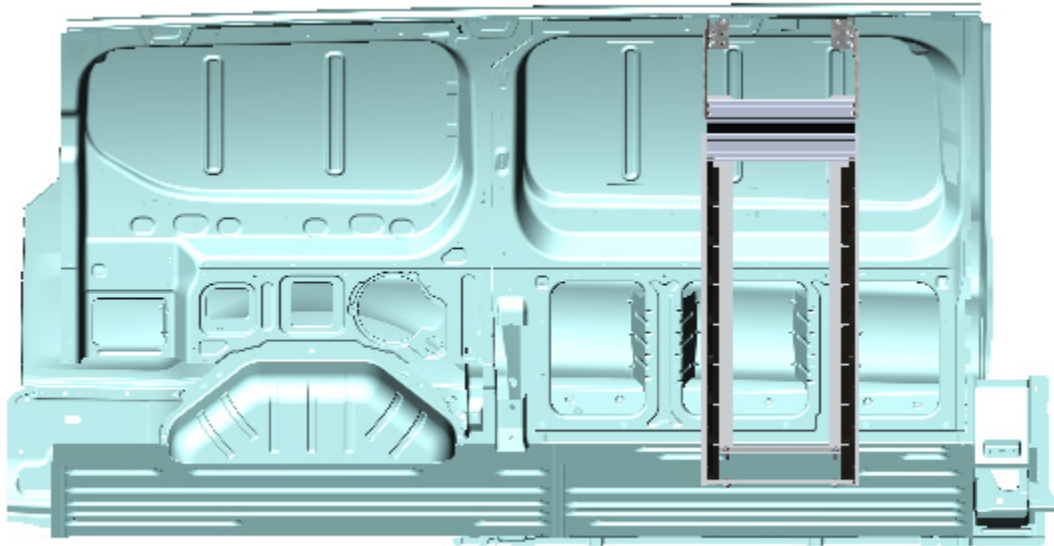

TOOLS

- Cordless Impact
- 1/2" Socket

FASTENERS USED

4x WALL KITS FASTENER KIT



#90-212 Hex Bolt 5/16" x 1-1/4"



#98-122 Lock Washer



#98-116 Flat Washer



#94-150 Channel Nut

IMPORTANT: After checking all bolts are tightened slide 8 partskeeper case to the cabinet.

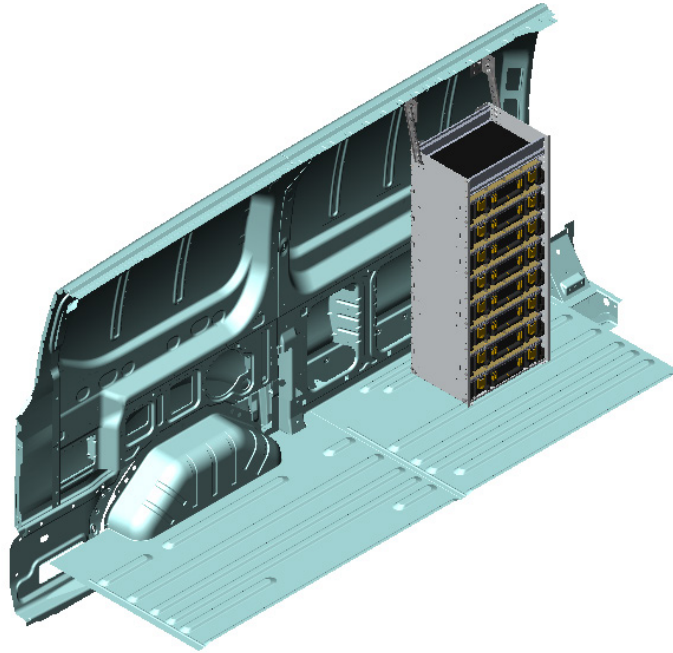

**“You have successfully installed your
C4-PA18-8C**

Thank you for doing business with us.”

For any feedback or suggestions you may have, please contact: cs@rangerdesign.com

