

INSTALLATION GUIDE

STEP 2 - CROSSBARS SET UP

CROSSBARS NOT INCLUDED.



Max Rack:
Passenger side

18-U1810

Scan the QR for the latest Install-Guide.



FASTENERS USED 4x (12 ft • lbs)

- #90-203 Hex Bolt 5/8"
- #98-123 Lock Washer 5/16"
- #98-117 Flat Washer 5/16"
- #94-250 Channel Nut 5/16"

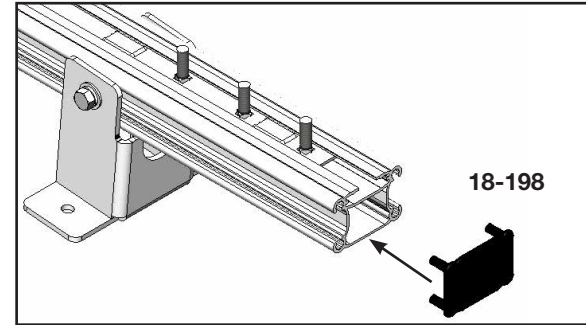
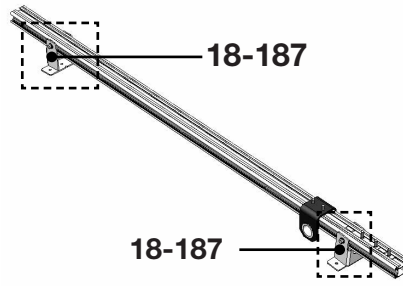
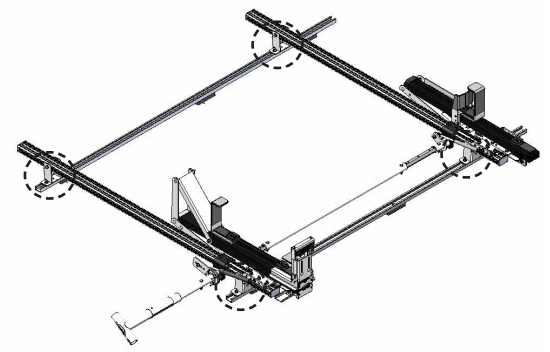

Repeat for both crossbars.

FOOT PLACEMENT GUIDE

VEHICLE	DIMENSION (A)
NISSAN NV	7"
SPRINTER	10" HIGH ROOF
SPRINTER	6-1/2" STANDARD ROOF
TRANSIT	8 - 7/8"
PROMASTER	7 - 1/16"

SET-UP-BOM & TOOLS

Item No.	Description	Qty.
18-004	SPACER, MAX RACK	1
18-009	DAMPER	1
18-010	GAS SPRING	1
18-167	GAS SPRING COMBO	1
18-192	INSERT PLATE	2
18-4010	SHAFT SUPPORT BRACKET	2
40-665	BALL STUD	2
90-225	BOLT HEX HEAD 5/16" - 18 X 2" SS304	5
90-491	BOLT CARRIAGE 5/16" - 18x1" SS304	10
94-111	NUT LOCK HX-HD NYL-INSRT 5/16"-18 SS304 WAX	17
98-117	WASHER FLAT 5/16", 3/4" OD, SST	24
18-4001	REAR MECHANISM - PASSENGER SIDE	1
18-4002	FRONT MECHANISM, PASSENGER SIDE	1
18-4005	REAR SHAFT ASSEMBLY, PASSENGER SIDE	1
18-4022	FRONT HEX BAR ASSEMBLY, PASSENGER SIDE	1
18-4023	REAR HEX BAR ASSEMBLY, PASSENGER SIDE	1
18-256	ADJUSTABLE PIVOT CENTER TUBE	1

REQUIRED ITEMS

- Ladder
- 1/2" Wrench
- 1/2" Socket
- Anti-seize compound
- Cordless Impact
- Ratchet
- Tape Measure
- Marker

2 PERSON

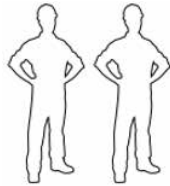

STEP 3 - REAR & FRONT MECHANISM INSTALL

Use anti-seize on threaded bolts.

FASTENERS USED 2x (12 ft • lbs)

- #40-665 Ball stud
- #98-117 Flat Washer 5/16"
- #98-117 Flat Washer 5/16"
- #94-111 Lock Nut 5/16"

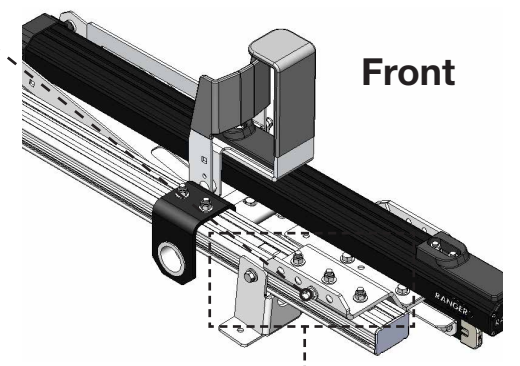
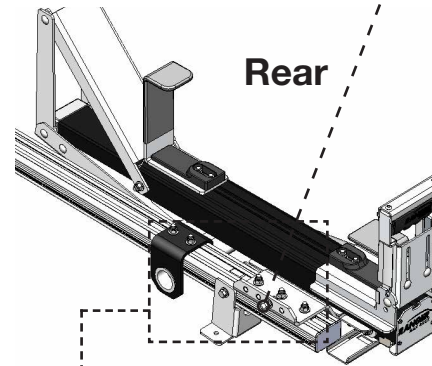
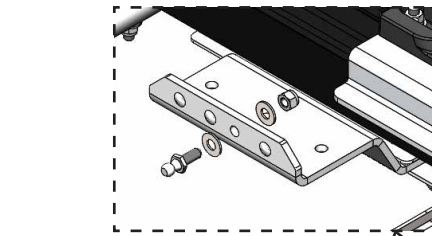

FASTENERS USED 10x (12 ft • lbs)

- #94-111 Lock Nut 5/16"
- #98-117 Flat Washer 5/16"

STEP 1 - CARRIAGE BOLT PLATE INSTALL

FASTENERS USED 5x

- (A)** #90-491 Carriage Bolt 1"

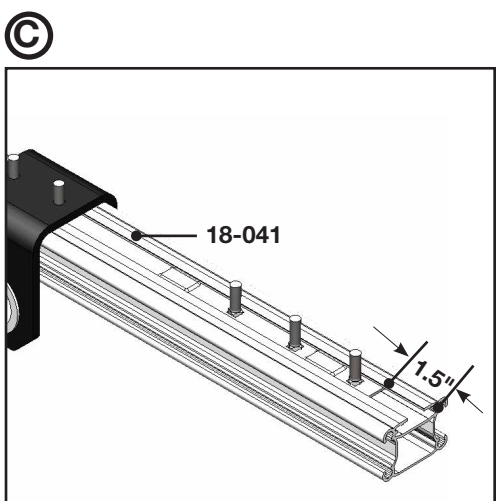
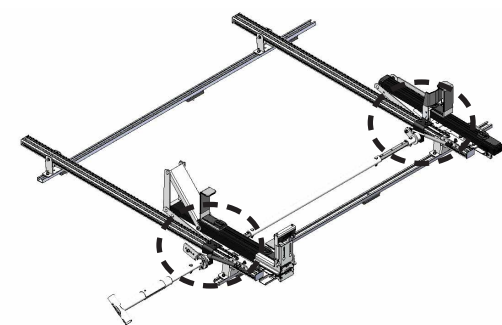
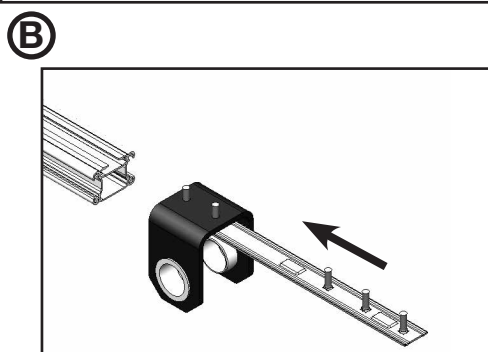
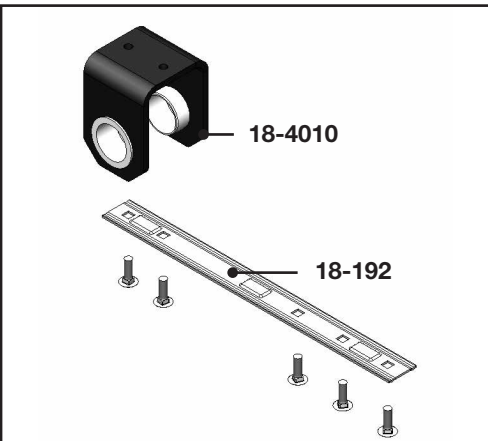

STEP 4 - REAR HEX SHAFT INSTALL

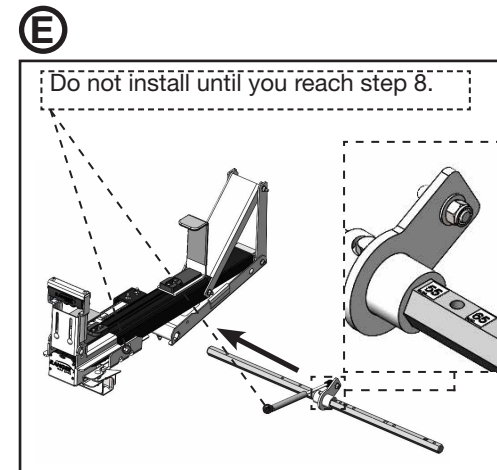
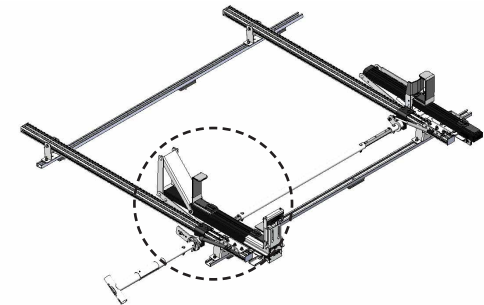
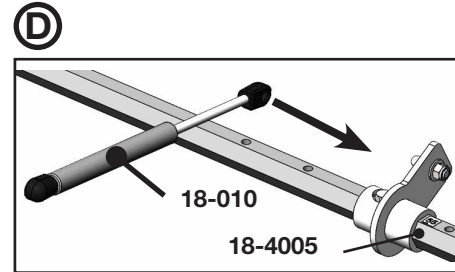

To allow for better access, lower arm to insert hardware.

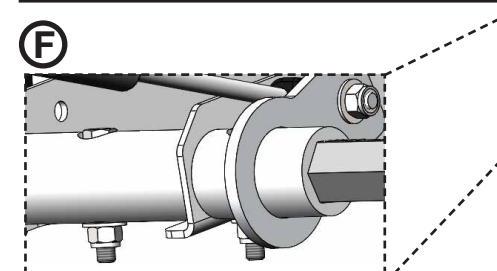

FASTENERS USED 1x (12 ft • lbs)

- #90-225 Hex Bolt 2"
- #98-117 Flat Washer 5/16"
- #98-117 Flat Washer 5/16"
- #94-111 Lock Nut 5/16"



For technical support, contact us at 1-800-565-5321

STEP 5 - INSTALL FRONT HEX SHAFT

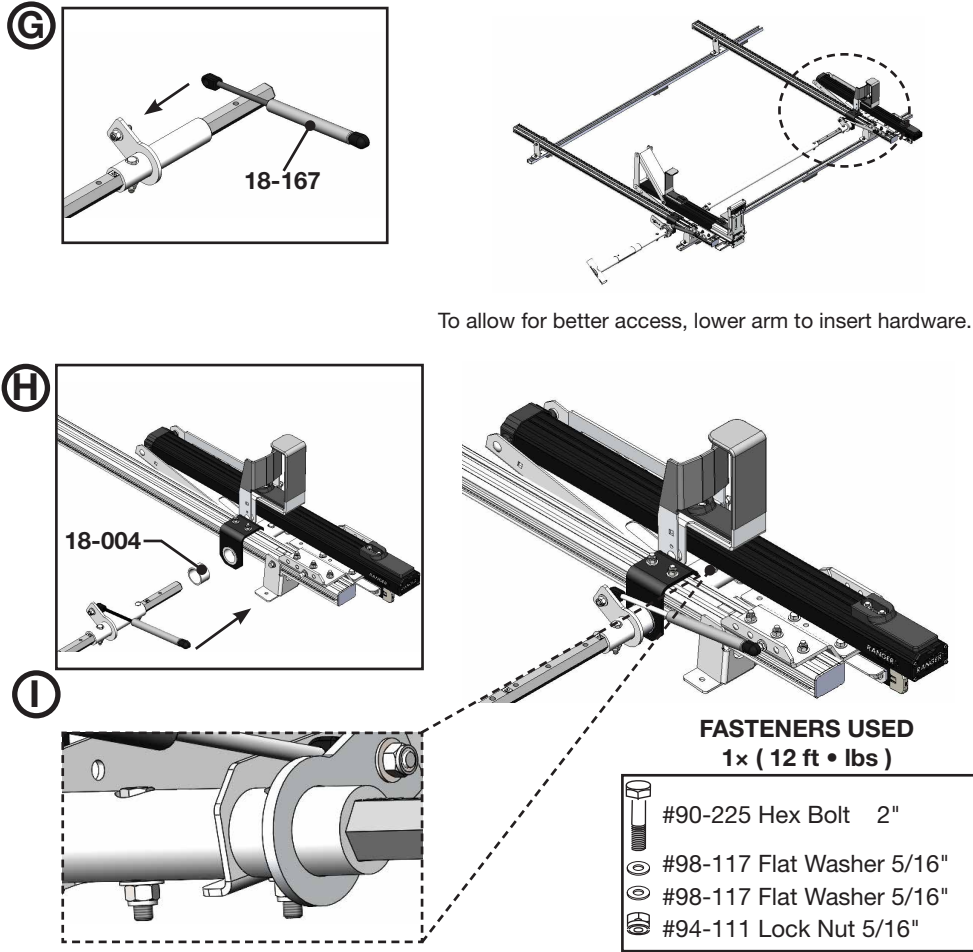

STEP 8 - INSTALL GAS CYLINDERS

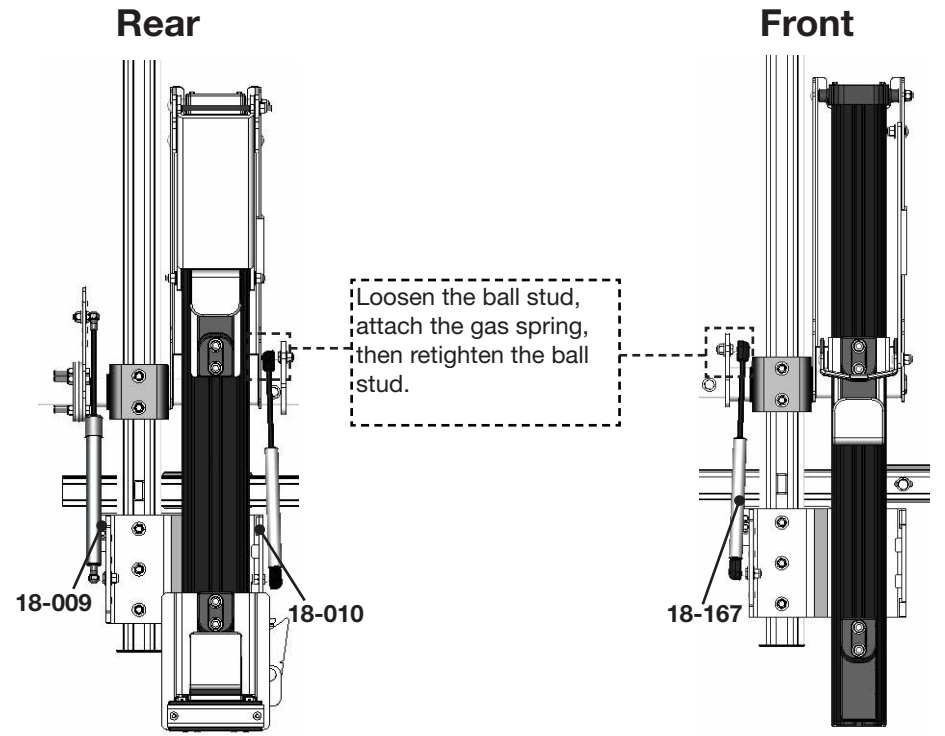

STEP 6 - INSTALL CENTER TUBE

Refer to numbered spacing provided on the hex bar.

FASTENERS USED
2x (12 ft • lbs)

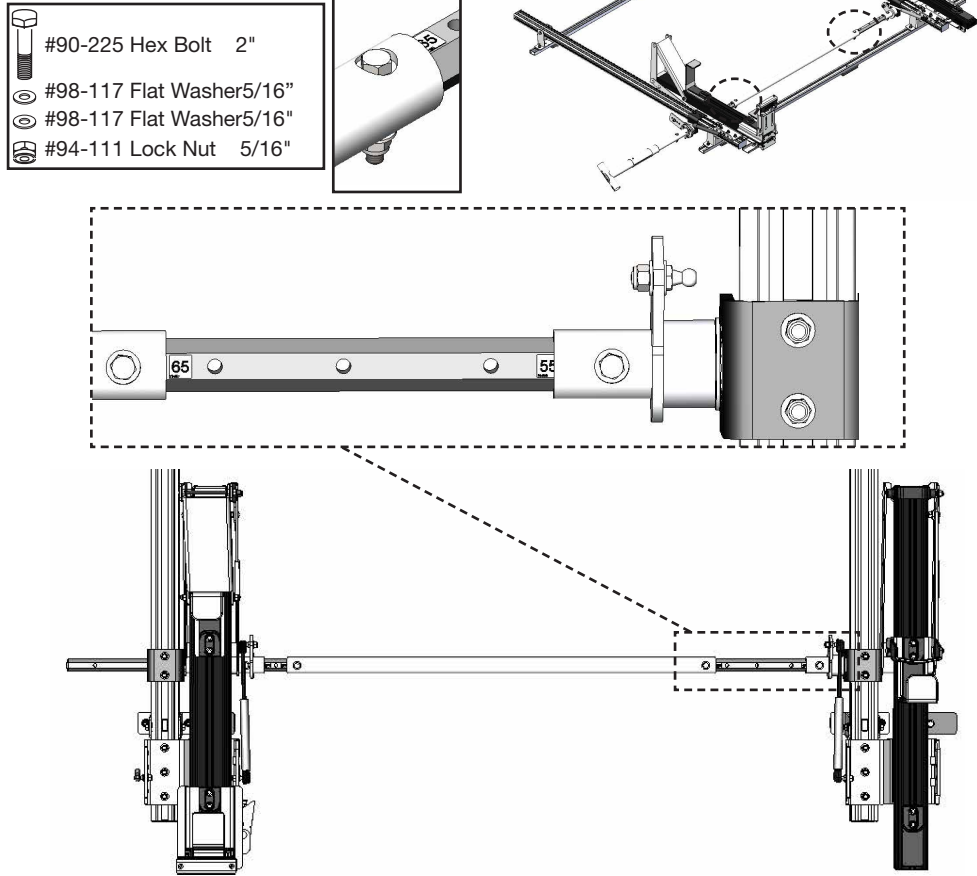

STEP 9 - VAN ROOF INSTALLATION

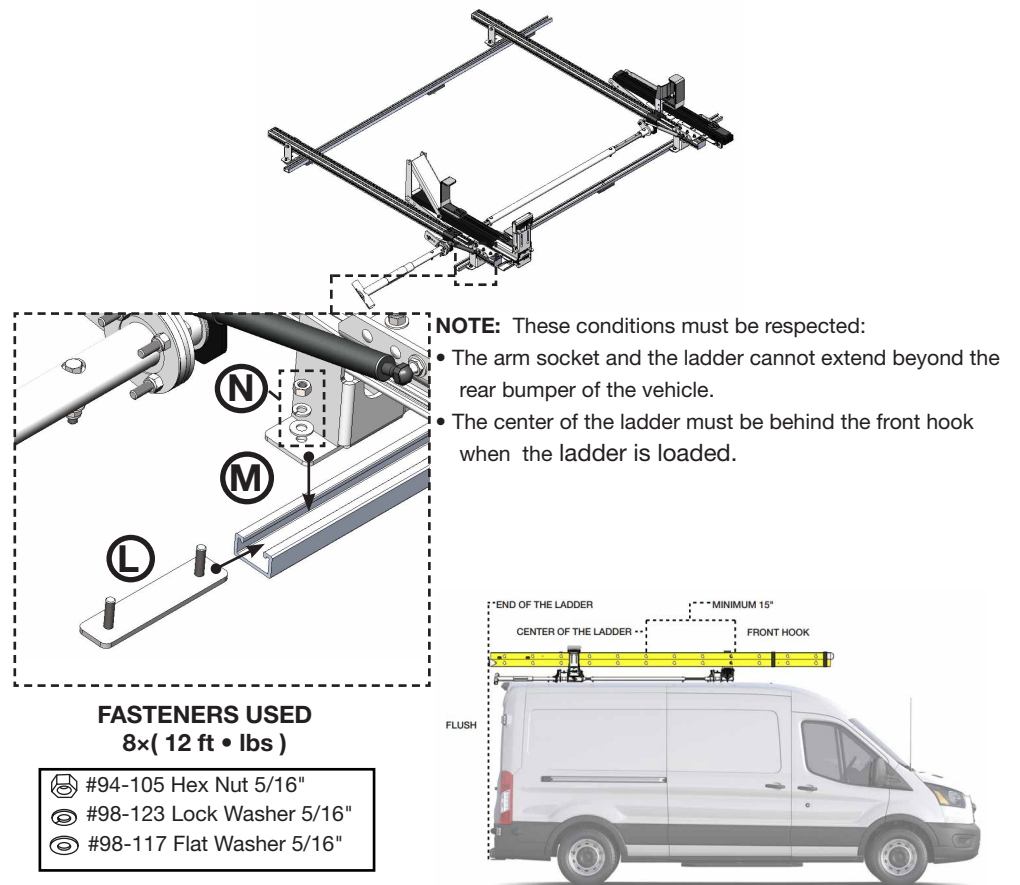

STEP 7 - ATTACH REAR ELBOW

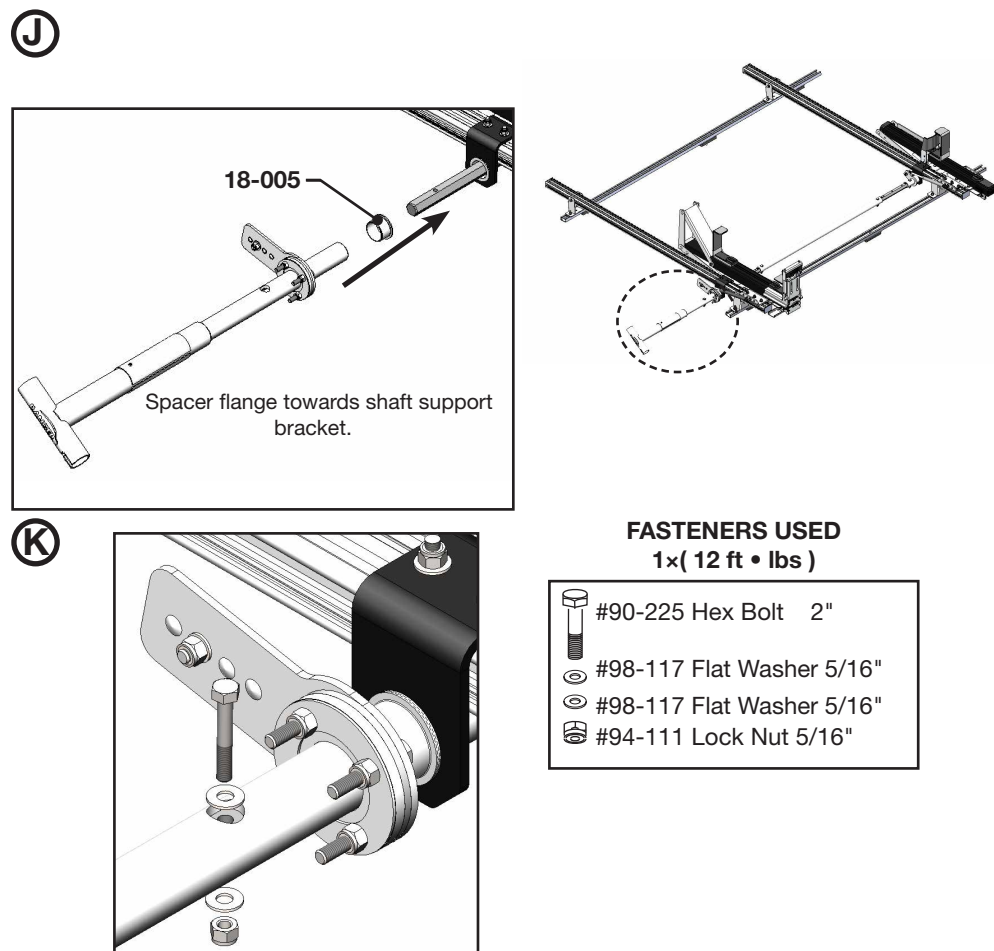

STEP 10 - STICKER PLACEMENTS

NOTE:

- Place the Max Rack in the down position.
- Load the ladder onto the Max Rack.
- Follow direction in **Operator's Manual** to adjust hooks to ladder.
- Include **Operator's Manual** in the cab for end user.
- If you don't have the ladder of the end user, explain to end user where to put the **Ladder sticker**.

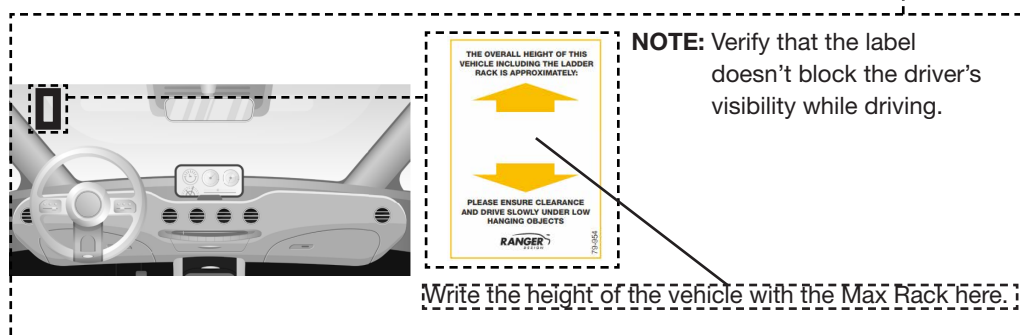
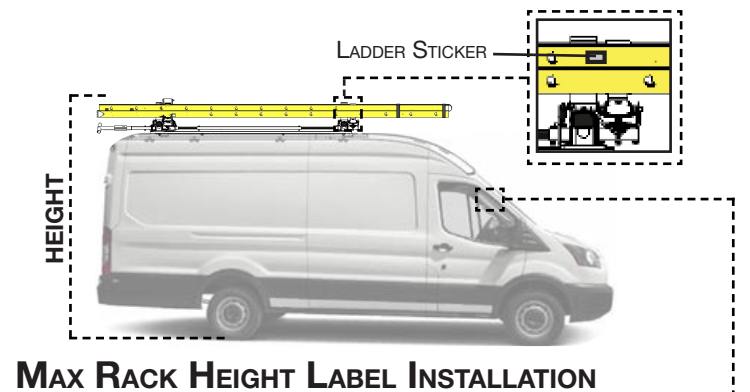



BEFORE YOU BEGIN

READ, UNDERSTAND, AND FOLLOW ALL WARNINGS AND INSTRUCTIONS BEFORE USING THIS PRODUCT. FAILURE TO FOLLOW THESE DIRECTIONS MAY RESULT IN PROPERTY DAMAGE, SERIOUS BODILY INJURY, AND/OR DEATH. RANGER DESIGN IS NOT RESPONSIBLE FOR ANY PROPERTY DAMAGE, PERSONAL INJURY, OR DEATH THAT OCCURRED WHILE USING ANY RANGER DESIGN PRODUCTS.



WARNING

- Failure to use Ranger Design-provided fasteners, brackets, and proper installation guidelines could increase risk of serious personal injury and/or death.
- If drilling is required to complete this installation: improper drilling can cause property damage to vehicles and could lead to electric shock, fire, or even death.
- If drilling is required to complete this installation: Ensure that drilling is only performed on areas of the vehicle allowed by the vehicle's Original Equipment Manufacturer's Body Builders Layout Book (or equivalent document).
- Prior to installation, inspect the vehicle to ensure that installation will not interfere with, or cause obstruction of, any critical components such as electrical wiring, fuel tanks, fuel-cells, locks, latches, etc.
- The installer or manufacturer is responsible for ensuring anchorages are installed onto suitable wall and floor structures; wall and floor strength must meet applicable performance requirements.
- Do not install systems into any weak or unsound materials such as plastics, woods, thin-walled metals, etc. without proper reinforcement.
- Do not install this product where it could interfere with the deployment of airbags. Failure to comply could result in death or serious injury.
- Incorrect installation could cause water leaks, electric shock or fire.
- Any cargo vehicle with any cargo or equipment should use a certified partition. See Ranger Design website for some partition options. (<https://rangerdesign.com/>)
- Mountings rails are recommended for any attachment to the vehicle walls.
- All items in the cargo area should be properly secured and partition doors closed while the vehicle is in motion.
- Check your vehicle's tare weight and remaining load capacity with all the equipment installed. Never exceed the maximum Gross Vehicle Weight Rating (GVWR), Gross Axle Weight Ratings (GAWRs), or other maximum loads permitted by the vehicle's Original Equipment Manufacturer (OEM) and required by law.
- The heaviest items must be placed towards the bottom of the vehicle, while the lightest ones can be arranged upwards. Vehicle cargo loading weight proportion should follow the following guidelines:

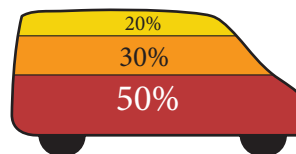

- The final alterer and/ or modifier should review the warning sheet with the customer before the vehicle is released to the customer or for general use. These instructions should remain with the vehicles a all times.
- Any modification or unintended use of this product voids any warranty and could create a hazardous condition.
- Ranger Design provides recommended assembly and installation instructions which should be followed to ensure correct operation. Failure to do so could result in invalidating the product's compliance, warranty and cause injury. Notwithstanding, the final stage vehicle alterer and/or modifier is responsible for the integration, installation, and compliance of the product in its final location to all applicable regulations and standards. Failure to maintain compliance of the vehicle to applicable regulations and standards could be punishable by law. Alterers and/or modifiers should consult with all local authorities prior to commissioning.



CAUTION

- If drilling is required to complete this installation. Before drilling, ensure that you will not hit any critical parts of the vehicle like the gas tank, wiring harness, or hose. Consult the vehicle OEM documentation as necessary. When drilling, use a drill collar to reduce the risk of damage to the vehicle.
- Any materials, padding, or glazing installed in the vehicle must comply with FMVSS/CMVSS 201/205/302, as applicable.
- In the event of a motor vehicle accident or collision where a Ranger Design system has been installed, especially ones where the vehicle structure is damaged and/or the air bags deploy and/or the vehicle has been towed, the system must be inspected to ensure continued soundness and safety before returning the vehicle to service. Damaged components should be replaced as necessary.
- All system components should be regularly inspected, cleaned, and maintained pursuant to Ranger guidelines.